

Installation Guide

Avigilon™ H4 HD Bullet Camera Models:

H4A-BO1-IR, H4A-BO2-IR, H4A-G-BO1-IR, H4A-G-BO2-IR

Important Safety Information

This manual provides installation and operation information and precautions for the use of this camera. Incorrect installation could cause an unexpected fault. Before installing this equipment read this manual carefully. Please provide this manual to the owner of the equipment for future use.



The Warning symbol indicates the presence of dangerous voltage within and outside the product enclosure that may constitute a risk of electric shock, serious injury or death to persons if proper precautions are not followed.



The Caution symbol alerts the user to the presence of hazards that may cause minor or moderate injury to persons, damage to property or damage to the product itself if proper precautions are not followed.



WARNING — Failure to observe the following instructions may result in severe injury or death.

- Installation must be performed by qualified personnel only, and must conform to all local codes.
- This product is intended to be supplied by a UL Listed Power Unit marked “Class 2” or “LPS” or “Limited Power Source” with output rated 12 VDC or 24 VAC, 13 W min. or Power over Ethernet (PoE), rated 48 VDC, 13 W min.
- Any external power supply connected to this product may only be connected to another Avigilon product of the same model series. External power connections must be properly insulated.
- Do not connect directly to mains power for any reason.



CAUTION — Failure to observe the following instructions may result in injury or damage to the camera.

- Do not expose the camera directly to high levels of x-ray, laser, or UV radiation. Direct exposure may cause permanent damage to the image sensor.
- Do not install near any heat sources such as radiators, heat registers, stoves, or other sources of heat.
- Do not subject the cables to excessive stress, heavy loads or pinching.
- Do not open or disassemble the device. There are no user serviceable parts.
- Refer all servicing to qualified personnel. Servicing may be required when the device has been damaged (such as from a liquid spill or fallen objects), has been exposed to rain or moisture, does not operate normally, or has been dropped.
- Do not use strong or abrasive detergents when cleaning the device body.
- Use only accessories recommended by Avigilon.

Regulatory Notices

This device complies with part 15 of the FCC Rules. Operation is subject to the following two conditions: (1) this device may not cause harmful interference, and (2) this device must accept any interference received, including interference that may cause undesired operation.

This Class B digital apparatus complies with Canadian ICES-003.

FCC Notice

This equipment has been tested and found to comply with the limits for a Class B digital device, pursuant to Part 15 of the FCC rules. These limits are designed to provide reasonable protection against harmful interference in a residential installation. This equipment generates, uses and can radiate radio frequency energy and, if not installed and used in accordance with the instructions, may cause harmful interference to radio communications. However, there is no guarantee that interference will not occur in a particular installation. If this equipment does cause harmful interference to radio or television reception, which can be determined by turning the equipment off and on, the user is encouraged to try to correct the interference by one or more of the following measures:

- Reorient or relocate the receiving antenna.
- Increase the separation between the equipment and the receiver.
- Connect the equipment into an outlet on a circuit different from that to which the receiver is connected.
- Consult the dealer or an experienced radio/TV technician for help.

Changes or modifications made to this equipment not expressly approved by Avigilon Corporation or parties authorized by Avigilon Corporation could void the user's authority to operate this equipment.

Disposal and Recycling Information

When this product has reached the end of its useful life, please dispose of it according to your local environmental laws and guidelines.

Risk of fire, explosion, and burns. Do not disassemble, crush, heat above 100 °C (212 °F), or incinerate.

European Union:



This symbol means that according to local laws and regulations your product should be disposed of separately from household waste. When this product reaches its end of life, take it to a collection point designated by local authorities. Some collection points accept products for free. The separate collection and recycling of your product at the time of disposal will help conserve natural resources and ensure that it is recycled in a manner that protects human health and the environment.

Legal Notices

© 2017, Avigilon Corporation. All rights reserved. AVIGILON, the AVIGILON logo, AVIGILON CONTROL CENTER, ACC, and TRUSTED SECURITY SOLUTIONS are trademarks of Avigilon Corporation. Other names mentioned herein may be the trademarks of their respective owners. The absence of the symbols ™ and ® in proximity to each trademark in this document is not a disclaimer of ownership of the related trademark. Avigilon Corporation protects its innovations with patents issued in the United States of America and other jurisdictions worldwide: avigilon.com/patents. Unless stated explicitly and in writing, no license is granted with respect to any copyright, industrial design, trademark, patent or other intellectual property rights of Avigilon Corporation or its licensors.

Disclaimer

This document has been compiled and published covering the latest product descriptions and specifications. The contents of this document and the specifications of the products discussed herein are subject to change without notice. Avigilon Corporation reserves the right to make any such changes without notice. Neither Avigilon Corporation nor any of its affiliated companies: (1) guarantees the completeness or accuracy of the information contained in this document; or (2) is responsible for your use of, or reliance on, the information. Avigilon Corporation shall not be responsible for any losses or damages (including consequential damages) caused by reliance on the information presented herein.

Avigilon Corporation
avigilon.com

PDF-H4ABO-A

Revision: 4 - EN

20170307

Table of Contents

Overview	1
Mounting Bracket View	1
Rear View	2
Front View	3
Configuration Panel View	4
Side View	5
Installation	6
Camera Package Contents	6
Precautions for Installing Near Salt Water	6
Installation Steps	6
Mounting and Aiming Video Analytics Cameras	7
Installing the Mounting Bracket	7
(Optional) Removing the Sun Shroud	8
Reinstalling the Sun Shroud	8
Connecting Cables	8
Mounting the Camera	9
Removing the Configuration Panel Cover	10
(Optional) Using the USB Wi-Fi Adapter	11
Assigning an IP Address	11
Accessing the Live Video Stream	11
Aiming the Camera	11
Zooming and Focusing the Camera	12
(Optional) Configuring SD Card Storage	12
Setting the Time	13
Configuring the Camera	13
For More Information	13
Connecting to Power and External Devices	14
LED Indicators	16
Resetting to Factory Default Settings	17
Setting the IP Address Using the ARP/Ping Method	18
Specifications	19
Limited Warranty and Technical Support	21

Overview

Mounting Bracket View

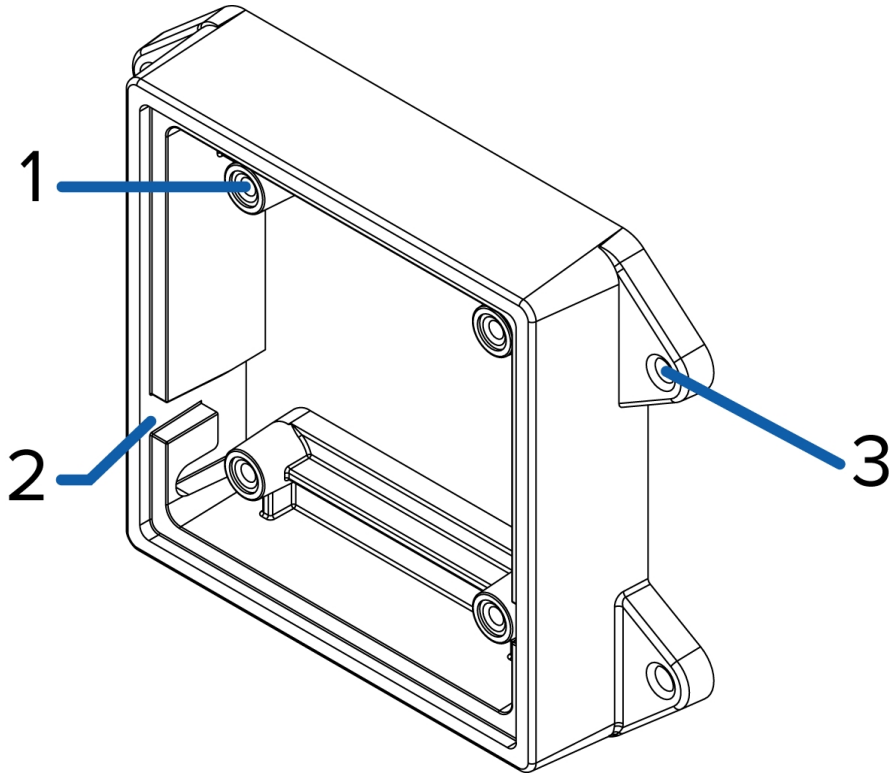

1. **Camera mounts**

Points for installing the camera to the mounting bracket.

2. **Mounting hook slots**

Points to hold the camera to the mounting bracket while connecting the required cables.

3. **Mounting holes**

Holes for securing the mounting bracket to the mounting surface.

Rear View

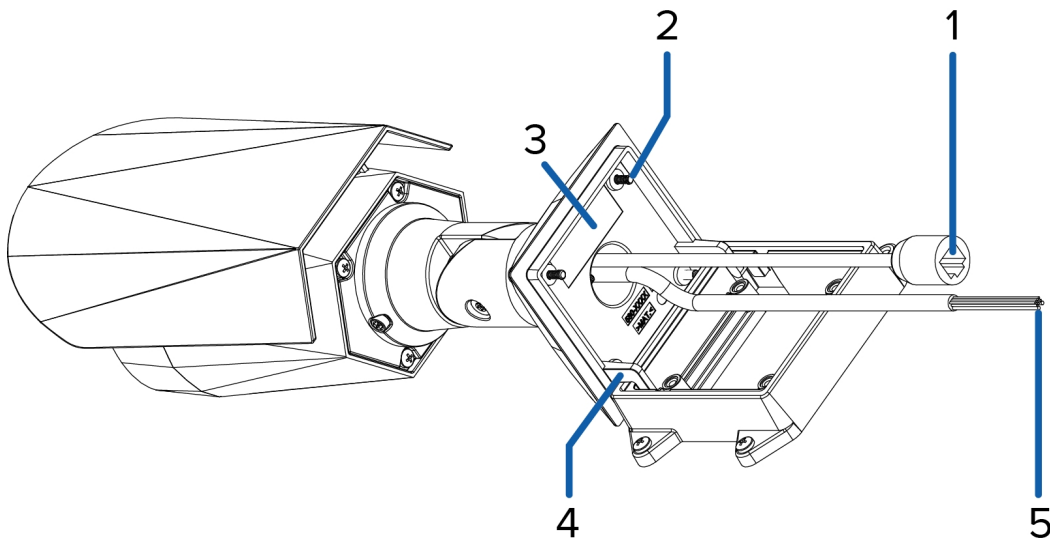

1. Ethernet port

Accepts an Ethernet connection to a network. Server communication and image data transmission occurs over this connection. Also receives power when it is connected to a network that provides Power over Ethernet.

2. Camera mounting screws

Screws for mounting the camera to the mounting bracket.

3. Serial number tag

Device information, product serial number and part number label.

4. Mounting hooks

Hooks to attach the camera to the mounting bracket while connecting the required cables.

5. Power and I/O cables

Cables for connecting the camera to auxiliary power and I/O devices. For more information, see *Connecting to Power and External Devices* on page 14.

Front View

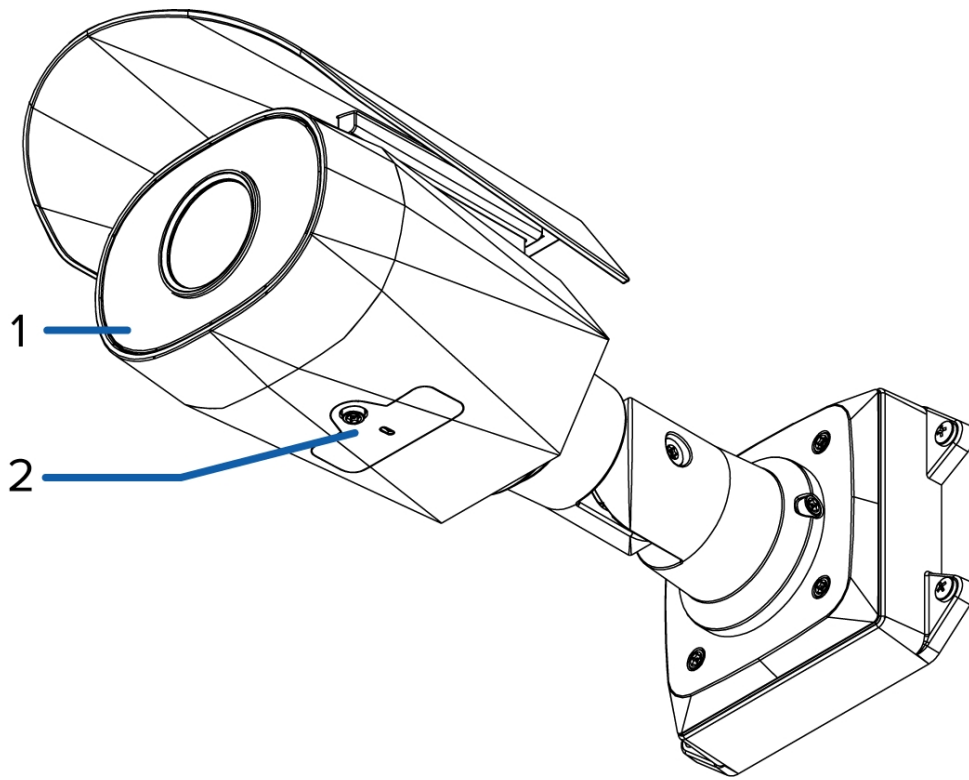

1. **IR illuminator**

Provides scene illumination in the IR spectrum.

2. **Configuration panel cover**

Covers the configuration panel. For more information on the configuration panel, see the *Configuration Panel View* on the next page.

Configuration Panel View

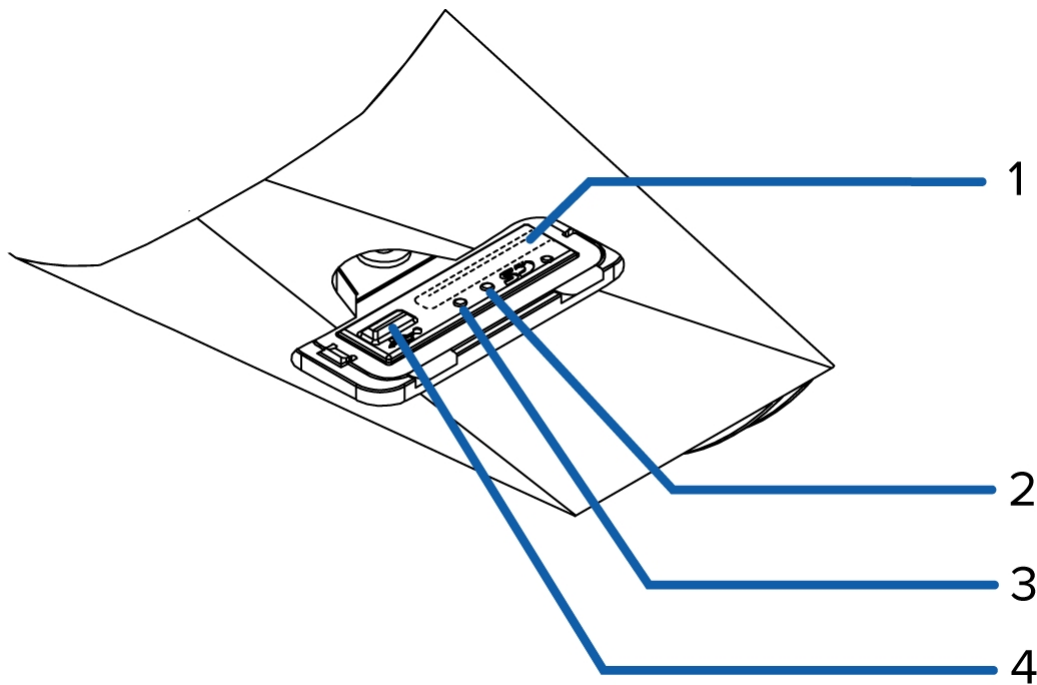

1. **SD card slot**

Accepts an SD card for onboard storage.

Not available on H4 Edge Solution (ES) Cameras.

2. **Link LED**

Indicates if there is an active connection in the Ethernet port.

3. **Connection status LED**

Provides information about camera operation. For more information, see *LED Indicators* on page 16.

4. **Micro USB port**

Accepts a micro USB to USB adapter. Only required when using the Avigilon USB Wi-Fi Adapter.

Side View

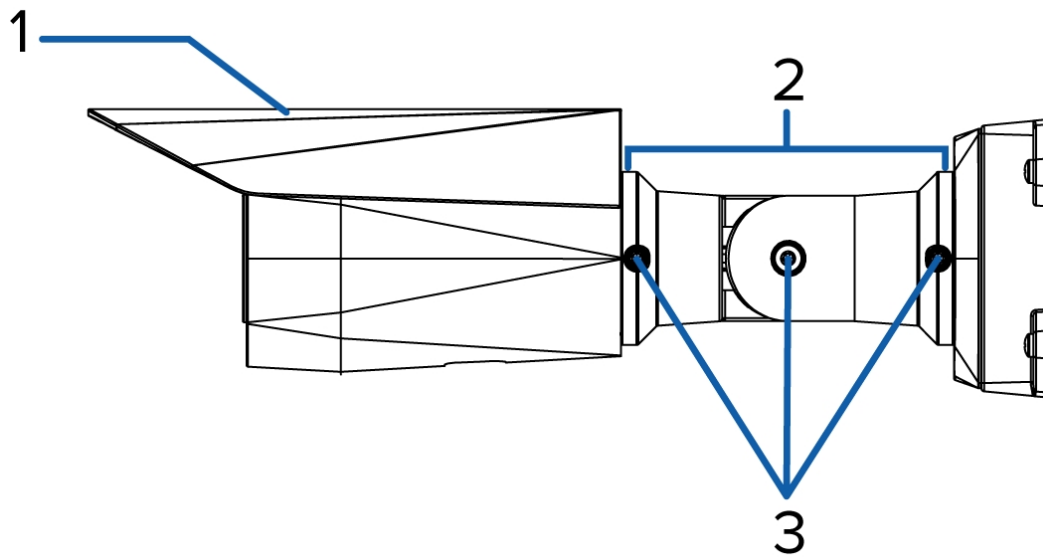

1. **Sun shroud**

An adjustable cover to help protect the lens against glare from the sun.

2. **Mount arm**

Adjustable mount arm for positioning the camera.

3. **Adjustment screws**

Provides a locking mechanism for the mount arm.

Installation

Camera Package Contents

- Avigilon H4 HD Bullet Camera
- Mounting template sticker
- 4 screws and anchors for solid walls
- Protective cable boot

Precautions for Installing Near Salt Water

Salt environments are hard on camera paint and external appearances but the camera's functionality will not be affected if the cameras are installed as described in this guide.

Follow these precautions to avoid camera issues when installing in a salt heavy environment:

- Use mounting accessories offered by Avigilon. All Avigilon accessories are tested to work with Avigilon cameras in the rated environments.
- If you use a third-party accessory, you *must* ensure that the material is compatible with the finish of the camera housing or galvanic corrosion may occur.
- Never pair steel mounting accessories with aluminum camera enclosures. Steel corrodes aluminum when salt is introduced. The corrosion is an electrochemical reaction and will cause the corrosion to spread across the entire camera body.
- Always insulate any camera surface that is in contact with another metal or conductive material. It is recommended that you always isolate the mounting screws from the mounting surface and camera housing with rubber or plastic shoulder washers.

Installation Steps

Complete the following steps to install the camera:

<i>Mounting and Aiming Video Analytics Cameras</i>	7
<i>Installing the Mounting Bracket</i>	7
<i>(Optional) Removing the Sun Shroud</i>	8
<i>Connecting Cables</i>	8
<i>Mounting the Camera</i>	9
<i>Removing the Configuration Panel Cover</i>	10
<i>(Optional) Using the USB Wi-Fi Adapter</i>	11
<i>Assigning an IP Address</i>	11
<i>Accessing the Live Video Stream</i>	11

<i>Aiming the Camera</i>	11
<i>Zooming and Focusing the Camera</i>	12
<i>(Optional) Configuring SD Card Storage</i>	12
<i>Setting the Time</i>	13
<i>Configuring the Camera</i>	13

Mounting and Aiming Video Analytics Cameras

When installing an Avigilon video analytics camera, follow the listed mounting and aiming recommendations to maximize the camera's analytics capabilities:

- The camera should be installed above 274 cm (9').
- The camera should tilt downwards no more than 45 degrees.
- The camera image should be level with the horizon line.
- The camera should be mounted to a stable surface to minimize the physical movement of the camera after installation.

For more details, see *Designing a Site for Video Analytics*. The document is available in the eDocs app and on the Avigilon website.

Installing the Mounting Bracket

If the cables for the camera will not be provided from inside the mounting surface, install the junction box first (H4-BO-JBOX). It is highly recommended that the junction box be used if you will be installing the camera with auxiliary power or external digital inputs and outputs.

After you install the junction box, you can skip directly to step 3 of this procedure.

1. Use the mounting template to drill four mounting holes into the mounting surface.
2. Drill the cable entry hole into the mounting surface then pull the required cables through the cable entry hole.
3. Fasten the mounting bracket to the mounting surface or junction box.

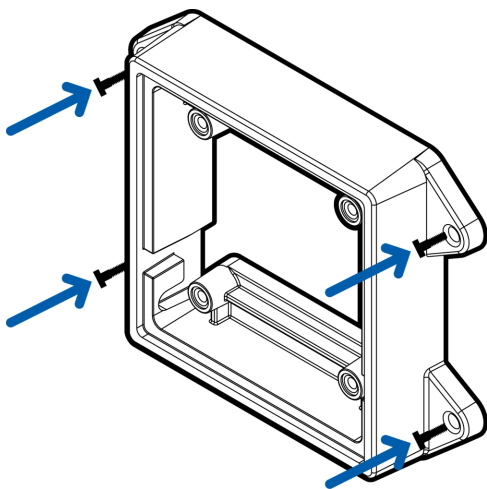

NOTE: It is recommended that silicone sealant be applied around the edge of the mounting bracket to prevent moisture from entering the mounting surface.

4. Insert the mounting hooks on the rear of the camera into the mounting hook slots on the mounting bracket, then let the camera hang.

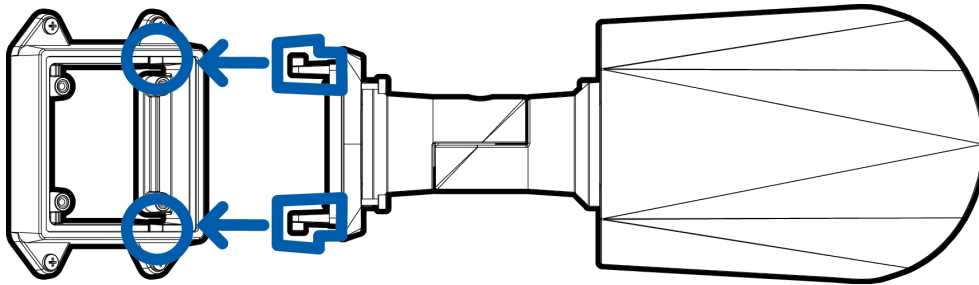

(Optional) Removing the Sun Shroud

The sun shroud should only be removed when the camera is installed indoors and space is limited.

1. As you press down on the center of the sun shroud, pull up the corners of the shroud from one side of the camera.
2. Use a T20 Pin-In Torx driver to unscrew and remove the sun shroud mount from the camera.

Reinstalling the Sun Shroud

1. Use a T20 Pin-In Torx driver to screw on the sun shroud mount.
2. Align one side of the sun shroud to the mount.
3. Press down on the center of the sun shroud and flex the edges up, then lower it into place.

Connecting Cables

Before connecting any cables, ensure that the cable connections are properly protected from moisture and corrosion. The optional junction box (H4-BO-JBOX) provides a watertight seal that helps prevent moisture from corroding the cable connections.

If you are not using the optional junction box, make sure the protective cable boot is installed over the Ethernet port to protect the connection from dust and moisture.

1. If there are external input or output devices that need to be connected to the camera (for example: door contacts, relays, etc.), connect the devices to the camera's digital I/O connector cables. For more information see *Connecting to Power and External Devices* on page 14.
2. If an external microphone and/or speakers need to be connected to the camera, connect the devices to the camera's audio I/O cables. For more information, see *Connecting to Power and External Devices* on page 14.

3. Install the protective cable boot. You may choose to skip this step if you are using the optional junction box.

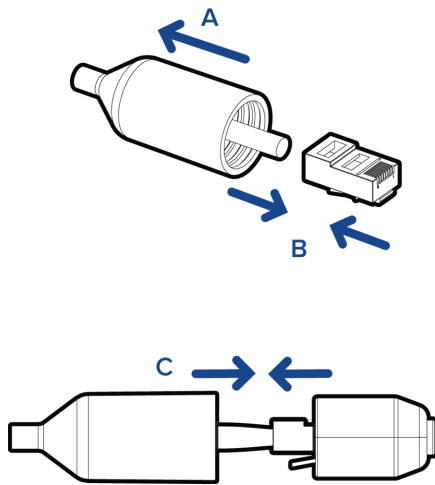

- a. Remove the protective cable boot that is preinstalled over the Ethernet port, then thread one end of the Ethernet cable through it.
Ensure the orientation of the cable and boot matches the one shown in the image.
 - b. Crimp the Ethernet cable.
 - c. After you connect the cable to the camera, slide the boot over the Ethernet port.
4. Connect a network cable to the Ethernet port (RJ-45 connector).
The Link LED will turn on once a network link has been established.
 5. Connect power using one of the following methods:
 - Power over Ethernet (PoE) Class 3 — If PoE is available, the camera LEDs will turn on.
 - External Power — Connect an external 12 V DC or 24 V AC power source through the brown and blue auxiliary power cables.

Important: Be careful not to connect power to the audio input cable, doing so will permanently damage the camera. Both the audio input cable and auxiliary power cable are brown. To distinguish the auxiliary power cable, it is labeled *AUX PWR* and has a thicker gauge.
 6. Check that the Connection Status LED indicates the correct state. For more information, see *LED Indicators* on page 16.

Mounting the Camera

Once all the cable connections have been made, secure the camera to the mounting bracket.

1. Tuck the extra lengths of cables into the cable entry hole.
2. Secure the camera to the mounting bracket:
 - a. Raise the camera until it covers the mounting bracket.

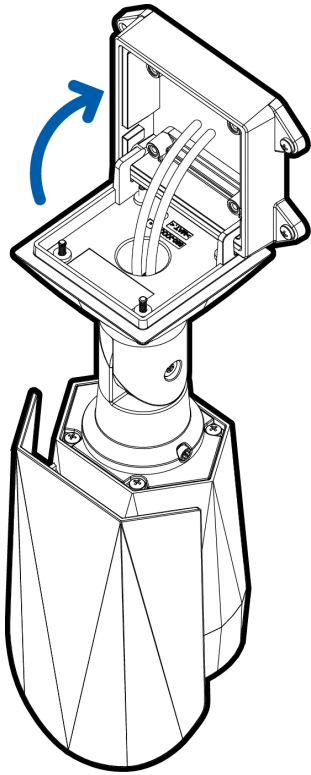

- b. Use the camera mounting screws to fasten the camera to the bracket.

Removing the Configuration Panel Cover

1. Use a T20 Pin-In Torx driver to unscrew the configuration panel cover.

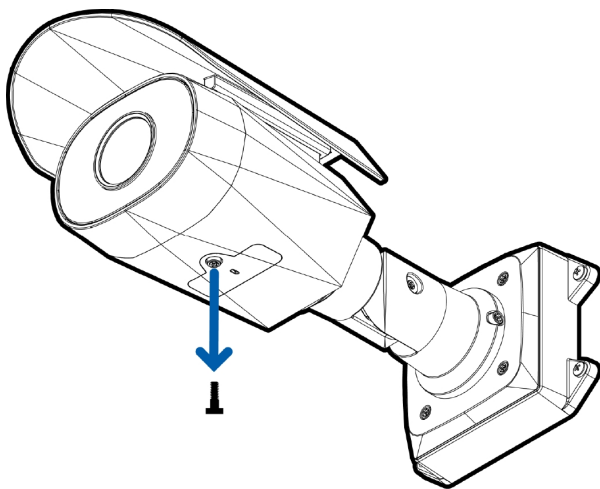

2. Remove the cover from the configuration panel.

(Optional) Using the USB Wi-Fi Adapter

If you have a USB Wi-Fi Adapter (H4-AC-WIFI), attach it to the camera's micro USB port to access the camera's mobile web interface.

After you connect to the Wi-Fi signal broadcast by the adapter, you can access the mobile web interface from any mobile device using the following address:

`http://camera.lan`

For more information about configuring the camera from the mobile web interface see *Avigilon USB Wi-Fi Adapter System User Guide*.

NOTE: The camera will reserve the 10.11.22.32/28 subnet for internal use while the USB Wi-Fi Adapter is plugged in.

Assigning an IP Address

The camera automatically obtains an IP address when it is connected to a network.

NOTE: If the camera cannot obtain an IP address from a DHCP server, it will use Zero Configuration Networking (Zeroconf) to choose an IP address. When set using Zeroconf, the IP address is in the 169.254.0.0/16 subnet.

The IP address settings can be changed using one of the following methods:

- The mobile web interface using the USB Wifi Adapter. For more information, see *(Optional) Using the USB Wi-Fi Adapter* above.
- Camera's web browser interface: `http://<camera IP address>/`.
- Network Video Management software application (for example, the Avigilon Control Center™ software).
- ARP/Ping method. For more information, see *Setting the IP Address Using the ARP/Ping Method* on page 18.

NOTE: The default camera username is `administrator` with no password.

Accessing the Live Video Stream

Live video stream can be viewed using one of the following methods:

- The mobile web interface using the USB Wifi Adapter. For more information, see *(Optional) Using the USB Wi-Fi Adapter* above.
- Web browser interface: `http://< camera IP address>/`.
- Network Video Management software application (for example, the Avigilon Control Center software).

NOTE: The default camera username is `administrator` with no password.

Aiming the Camera

Reference the camera's live stream as you aim the camera.

1. To aim the camera, loosen the adjustment screws on the camera mount arm.
2. Rotate and move the camera and mount arm as required. Review the camera's live video stream to help aim the camera correctly.

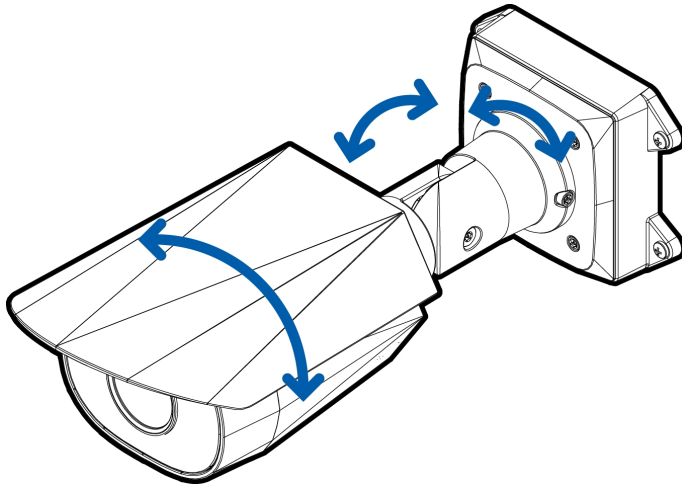

3. In outdoor installations, the sun shroud should be set as far forward as possible without intruding on the video image. Slide the sun shroud forward or back to protect the camera against glare from the sun.
4. Tighten the adjustment screws on the mount arm to secure the camera's position.
5. In the camera web browser interface or the Avigilon Control Center software adjust the camera's Image and Display settings. You can set the zoom position, focus and change the image rotation.

Zooming and Focusing the Camera

- In the camera web browser interface or the Avigilon Control Center software, use the camera's Image and Display settings to zoom and focus the camera.
 - a. Use the zoom buttons to zoom the camera in or out.
 - b. Click **Auto Focus** to focus the lens.
 - c. Use the focus near and far buttons to manually adjust the focus.

(Optional) Configuring SD Card Storage

To use the camera's SD card storage feature, you must insert an SD card into the card slot.

It is recommended that the SD card have a capacity of 8 GB or more and a write speed of class 6 or better. If the SD card does not meet the recommended capacity or write speed, the recording performance may suffer and result in the loss of frames or footage.

1. Insert an SD card into the camera.



CAUTION — Do not force the SD card into the camera or you may damage the card and the camera. The SD card can only be inserted in one direction.

2. Access the camera's web interface to enable the onboard storage feature. For more information, see the *Avigilon High Definition H.264 Camera Web Interface User Guide*.

Setting the Time

If you are installing an H4 ES camera, you must set the time on the camera. The ES camera model includes a built-in server component that runs the ACC Server software directly on the camera. Since the camera is accessed as its own network video recording server, you must set the time so that events and recorded video occur at the correct time.

1. Log in to the camera web interface.
2. Display the **Setup > Network** page.
3. In the Time Settings area, select the camera time zone.
4. Click **Apply**.
5. At the bottom of the Time Settings area, click the **Configure NTP Server** link.

If you cannot see the link, select **Network** from the left menu pane.

6. In the NTP Server area, make sure the check box is selected then choose one of the following options:
 - **DHCP:** select this option to automatically use an NTP server on the network.
 - **Manual:** select this option to manually enter a specific NTP server address in the **NTP Server** field.
7. Click **Apply**.

Configuring the Camera

Once installed, use one of the following methods to configure the camera:

- If you have the USB Wifi Adapter, you can access the mobile web interface to configure the camera. For more information, see *Avigilon USB Wi-Fi Adapter System User Guide*.
- If you have installed multiple cameras, you can use the Avigilon Camera Configuration Tool to configure common settings. For more information, see the *Avigilon Camera Configuration Tool User Guide*.
- If the camera is connected to the Avigilon Control Center system, you can use the client software to configure the camera. For more information, see the *Avigilon Control Center Client User Guide*.
- If the camera is connected to a third-party network management system, you can configure the camera's specialty features in the camera's web browser interface. For more information, see the *Avigilon H.264 Web Interface User Guide*.
- If you installed an H4 ES camera, you can use the Avigilon Control Center Client software to configure the camera and the embedded software.

For More Information

Additional information about setting up and using the device is available in the following guides:

- *Avigilon Control Center Client User Guide*
- *Avigilon High Definition H.264 Web Interface User Guide*
- *Avigilon Camera Configuration Tool User Guide*

The manuals are available on the Avigilon website: avigilon.com/support-and-downloads.

Connecting to Power and External Devices

Important: Be careful not to connect auxiliary power to the audio input wire or the camera will be damaged. Although both the audio input wire and auxiliary power wire are brown, the auxiliary power wire is distinguished by its thicker wire gauge and *AUX PWR* label.

If PoE is not available, the camera may be powered through the auxiliary power cable using either 12 V DC or 24 V AC. The power consumption information is listed in the product specifications.

To power the camera, connect the two power wires to the brown and blue auxiliary power wires. The connection can be made with either polarity.



WARNING — This product is intended to be supplied by a UL Listed Power Unit marked “Class 2” or “LPS” or “Limited Power Source” with output rated 12 VDC or 24 VAC, 13 W min. or PoE rated 48 VDC, 13 W min.

Power supplies and external devices are connected to the camera through the power and I/O wires. The pinout for the I/O and power wires is shown in the following diagram:

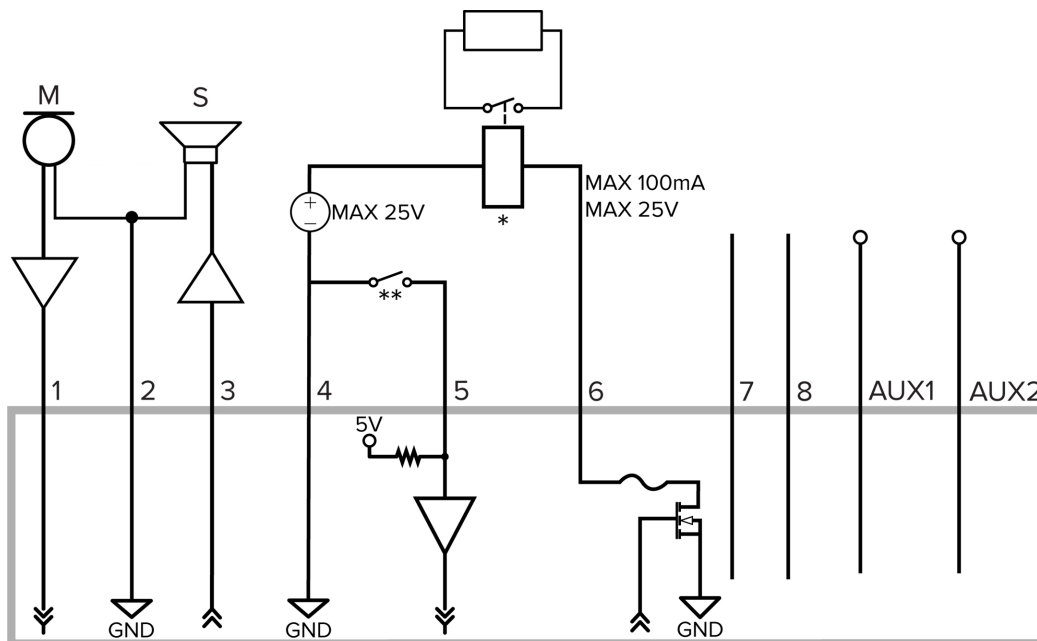

Figure 1: Example application.

1. Brown — Audio Input (line level)

An external power amplifier should be used when connecting speakers and microphones, as shown in the diagram.

2. Yellow — Audio Ground
3. Green — Audio Output (line level)
4. Grey — Ground
5. Red — Digital Input

6. Pink — Digital Output
7. Purple — Reserved Wire, do not connect.
8. White — Reserved Wire, do not connect.
 - * — Relay
 - ** — Switch
 - M — Microphone
 - S — Speaker
 - AUX1 — Brown Auxiliary Power Wire, labeled *AUX PWR*
 - AUX2 — Blue Auxiliary Power Wire

LED Indicators

Once connected to the network, the Connection Status LED will display the progress in connecting to the Network Video Management software.

The following table describes what the LEDs indicate:

Connection State	Connection Status LED	Description
Obtaining IP Address	One short flash every second	Attempting to obtain an IP address.
Discoverable	Two short flashes every second	Obtained an IP address but is not connected to the Network Video Management software.
Upgrading Firmware	Two short flashes and one long flash every second	Updating the firmware.
Connected	On	Connected to the Network Video Management software or an ACC™ Server.

Resetting to Factory Default Settings

If the camera no longer functions as expected, you can choose to reset the camera to its factory default settings.

Use the firmware revert button to reset the camera. The firmware revert button is shown in the following diagram:

NOTE: For the ES camera models, resetting the camera will erase all recorded video from the camera.

For models that feature an SD card slot, resetting the camera will not affect video that has been recorded to the SD card.

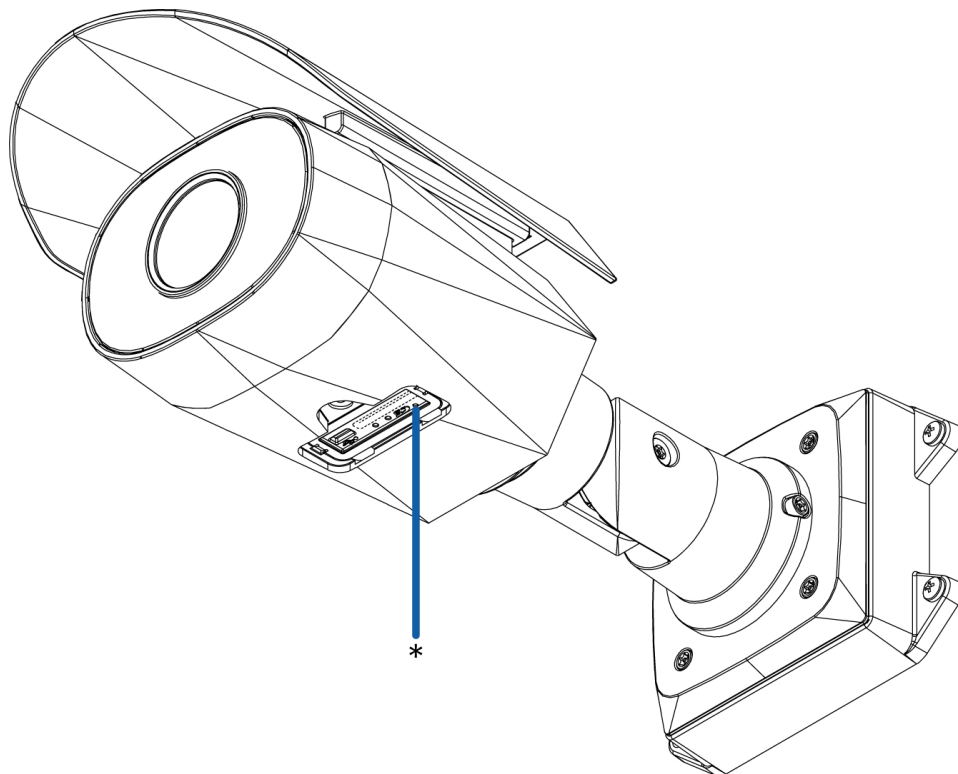

Figure 2: The firmware revert button in the Configuration Panel.

1. Ensure the camera is powered on.
2. Unscrew the configuration panel cover on the bottom of the camera.
3. Using a straightened paperclip or similar tool, gently press and hold the firmware revert button for 3 seconds.
4. Screw the configuration panel cover back into place.



CAUTION — Do not apply excessive force. Inserting the tool too far will damage the camera.

Setting the IP Address Using the ARP/Ping Method

Complete the following steps to configure the camera to use a specific IP address:

NOTE: The ARP/Ping Method will not work if the **Disable setting static IP address through ARP/Ping method** check box is selected in the camera's web browser interface. For more information, see the *Avigilon™ High Definition H.264 Web Interface User Guide*.

1. Locate and copy down the MAC Address (MAC) listed on the Serial Number Tag for reference.
2. Open a Command Prompt window and enter the following commands:
 - a. `arp -s <New Camera IP Address> <Camera MAC Address>`
For example: `arp -s 192.168.1.10 00-18-85-12-45-78`
 - b. `ping -l 123 -t <New Camera IP Address>`
For example: `ping -l 123 -t 192.168.1.10`
3. Reboot the camera.
4. Close the Command prompt window when you see the following message:

Reply from <New Camera IP Address>: ...

Specifications

Camera	
Audio Input/Output	Line level input and output
Lens	H4A-BO1-IR: <ul style="list-style-type: none"> • (1 – 3 MP models) 3-9 mm, F1.3, P-iris • (5 – 8 MP models) 4.3-8 mm, F1.8, P-iris H4A-BO2-IR: <ul style="list-style-type: none"> • (1 – 5 MP models) 9-22 mm, F1.6, P-iris
SD Storage (Models with SD card slots only)	SD/SDHC/SDXC slot – minimum class 4; class 6 or better recommended
Onboard Storage (ES models only)	<ul style="list-style-type: none"> • (1 MP model) 128 G • (2 – 3 MP models) 256 G
Network	
Network	100Base-TX
Cabling Type	CAT5
Connector	RJ-45
ONVIF	ONVIF compliance version 1.02, 2.00, Profile S (www.onvif.org). Compliant with version 2.2.0 of the Analytics Service Specification (bounding boxes and scene descriptions not available with third-party VMS)
Device Management Protocols	SNMP v2c SNMP v3
Security	Password protection, HTTPS encryption, digest authentication, WS authentication, user access log, 802.1x port based authentication.
Streaming Protocols	IPv4, HTTP, HTTPS, SOAP, DNS, NTP, RTSP, RTCP, RTP, TCP, UDP, IGMP, ICMP, DHCP, Zeroconf, ARP, RTP/UDP, RTP/UDP multicast, RTP/RTSP/TCP, RTP/RTSP/HTTP/TCP, RTP/RTSP/HTTPS/TCP, HTTP
Mechanical	
Dimensions L x W x H	126 mm x 280 mm x 91 mm (4.97" x 11.04" x 3.58")
Weight	Camera – 1.71 kg (3.77 lbs) Mounting bracket – 0.21 kg (0.46 lbs)
Body	Aluminum
Housing	Surface mount, vandal resistant
Finish	Powder coat, RAL 9003
Adjustment Range	±175° pan, ±90° tilt, ±175° azimuth

Cable Length	45 cm (17.72")
Electrical	
Power Consumption	13 W
Power Source	VDC: 12 V +/- 10%, 13 W min VAC: 24 V +/- 10%, 19 VA min PoE: IEEE802.3af Class 3
RTC Backup Battery	3V manganese lithium
Environmental	
Operating Temperature	-40 °C to +55 °C (-40 °F to 131 °F) 8.0 MP model — -35 °C to 50 °C (-31 °F to 122 °F) NOTE: IR illuminators will not turn on if the temperature is 45 °C (113 °F) or higher.
Storage Temperature	-10 °C to +70 °C (14 °F to 158 °F)
Humidity	0-95% non-condensing
Certifications	
Certifications	UL cUL CE ROHS WEEE RCM KC EAC
Safety	UL 60950-1 CSA 60950-1 IEC/EN 60950-1 IEC 62471
Environmental	IK10 Impact Rating Meets IEC 60529 IP66 Weather Rating IEC/UL/CSA 60950-22
Electromagnetic Emissions	FCC Part 15 Subpart B Class B EN 55032 Class B IC ICES-003 Class B EN 61000-6-3 EN 61000-3-2 EN 61000-3-3 KN 32
Electromagnetic Immunity	EN 55024 EN 61000-6-1 KN 35

Limited Warranty and Technical Support

Avigilon warranty terms for this product is provided at [avigilon.com/warranty](https://www.avigilon.com/warranty).

Warranty service and technical support can be obtained by contacting Avigilon Technical Support: [avigilon.com/contact-us/](https://www.avigilon.com/contact-us/).