

THIS DRAWING CONTAINS PROPRIETARY AND CONFIDENTIAL INFORMATION AND IS PROTECTED BY U.S. AND INTERNATIONAL LAW. UNAUTHORIZED REPRODUCTION, DISCLOSURE OR USE OF THE DRAWING OR THE INFORMATION THEREIN IS EXPRESSLY FORBIDDEN EXCEPT AS AGREED TO IN WRITING BY CHATSWORTH PRODUCTS, INC.

CONFIDENTIAL AND PROPRIETARY

Safety Information



WARNING: Improper use of this product or failure to follow these instructions may result in equipment damage, personal injury, or death. Read and understand all instructions for proper installation and use of this product.



WARNING: Before loading equipment in the cabinet, be sure all parts and hardware are properly installed and tightened.

INTENDED USE

INSTALL CUBE-IT ENCLOSURES ONLY IN INDOOR, NON-HAZARDOUS LOCATIONS. ALLOW ONLY QUALIFIED SERVICE PERSONNEL TO USE AND SERVICE THIS ENCLOSURE.

REMOVING REAR FRAME FROM CABINET

THIS STEP IS OPTIONAL, THE CABINET CAN BE MOUNTED WITH THE REAR FRAME ATTACHED

REVISION				
ISS	DESCRIPTION	DATE	APPROVED	
			CHK	ENG
3	PDM_ECO_C-9565	SJG 09/04/2018	SJG 09/04/2018	SJG 08/31/2018

- STEP 1. DETERMINE WHICH SIDE THE CABINET WILL HINGE FROM. THE CABINET IS SHOWN WITH THE HINGE ON THE LEFT SIDE, INVERT THE CABINET IF YOU WANT THE HINGE ON THE RIGHT SIDE.
- STEP 2. UNLOCK THE CENTER CHASSIS BY ROTATING THE BLUE LATCH COUNTER-CLOCKWISE AND SWING IT OPEN TO GET ACCESS TO THE HINGE BOLT PINS.
- STEP 3. WHILE CABINET IS SITTING ON A TABLE, LOOSEN THE SET SCREWS IN THE HINGES AND REMOVE THE HINGE PINS FROM BOTH HINGES.
- STEP 4. SLIDE THE REAR FRAME APART FROM THE CENTER CHASSIS.

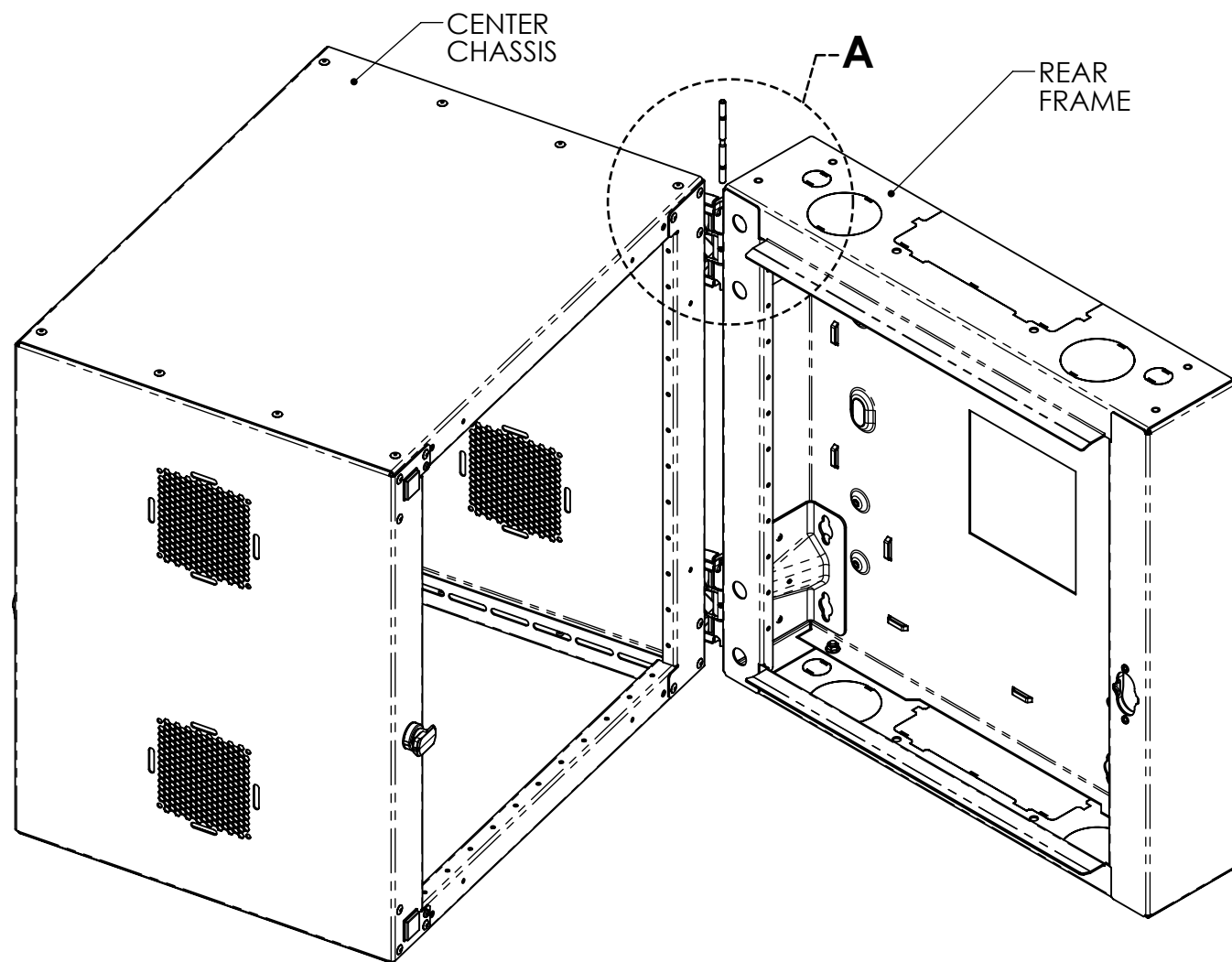

WITH CABINET SECURELY SITTING ON A TABLE, LOOSEN SET SCREWS IN BOTH HINGES TO ALLOW REMOVAL OF HINGE PINS

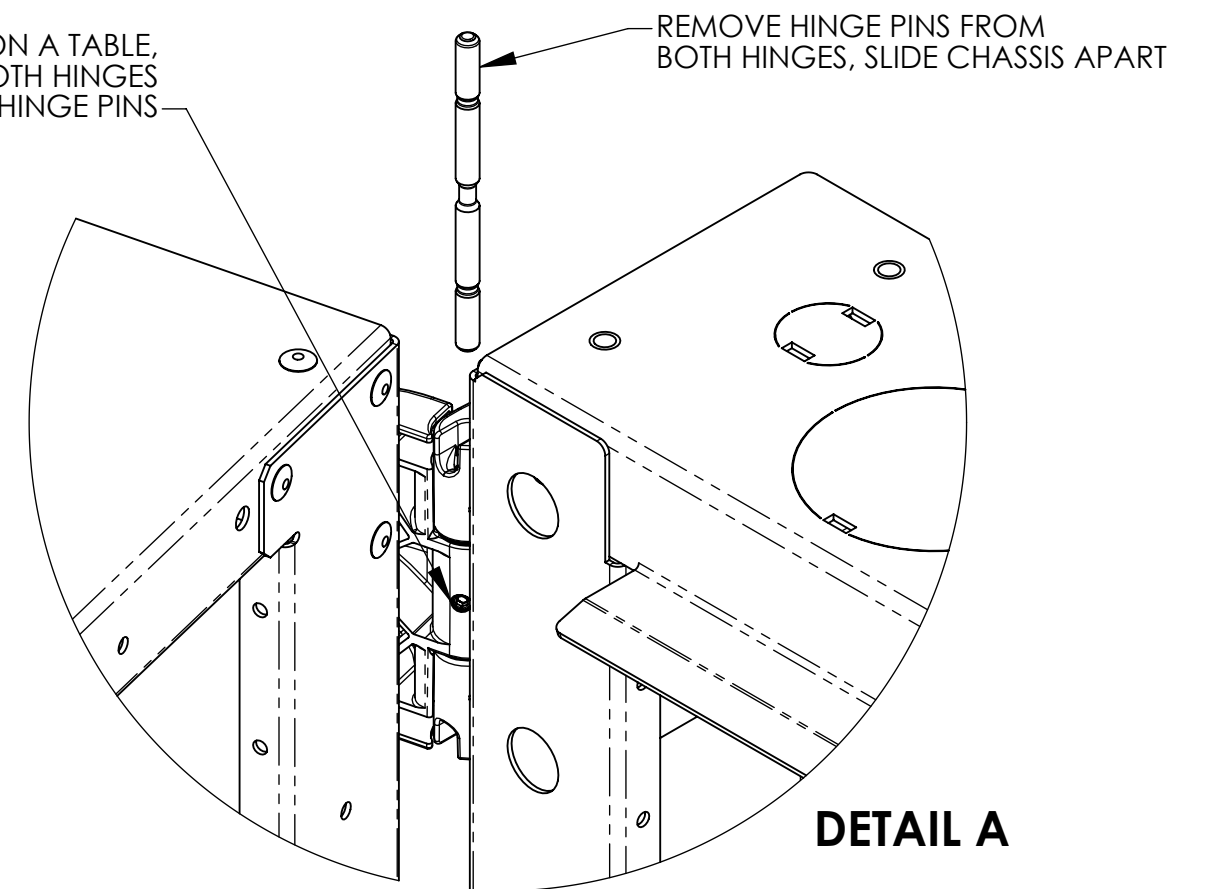

LOAD CAPACITY (per UL2416): 300 lb (163kg)

UNLESS OTHERWISE SPECIFIED ALL DIMENSIONS SHOWN ARE IN INCHES [MILLIMETERS] MILLIMETERS ARE REFERENCE ONLY SPECIFIED TOLERANCES ON .XX[X] .XXX[XX] ANGLE ±.03[±0.8] ±.010[±0.25] ±1° THIRD ANGLE	APPROVALS	DATE	CHATSWORTH PRODUCTS, INC.
	DR: S. GIBBLE	01/05/2018	
	CHKR: SJG	01/05/2018	
	MECH ENG: SJG	01/05/2018	
ITEM TO CONFORM TO OFC-754002 CORPORATE COSMETIC SPEC	ELEC ENG:		INSTL INSTR, CUBE-IT, G3
MATERIAL	FINISH		
			DWG SIZE B
			IIS-740900
			ISS 3
SCALE 1:4		SHEET 1 OF 5	

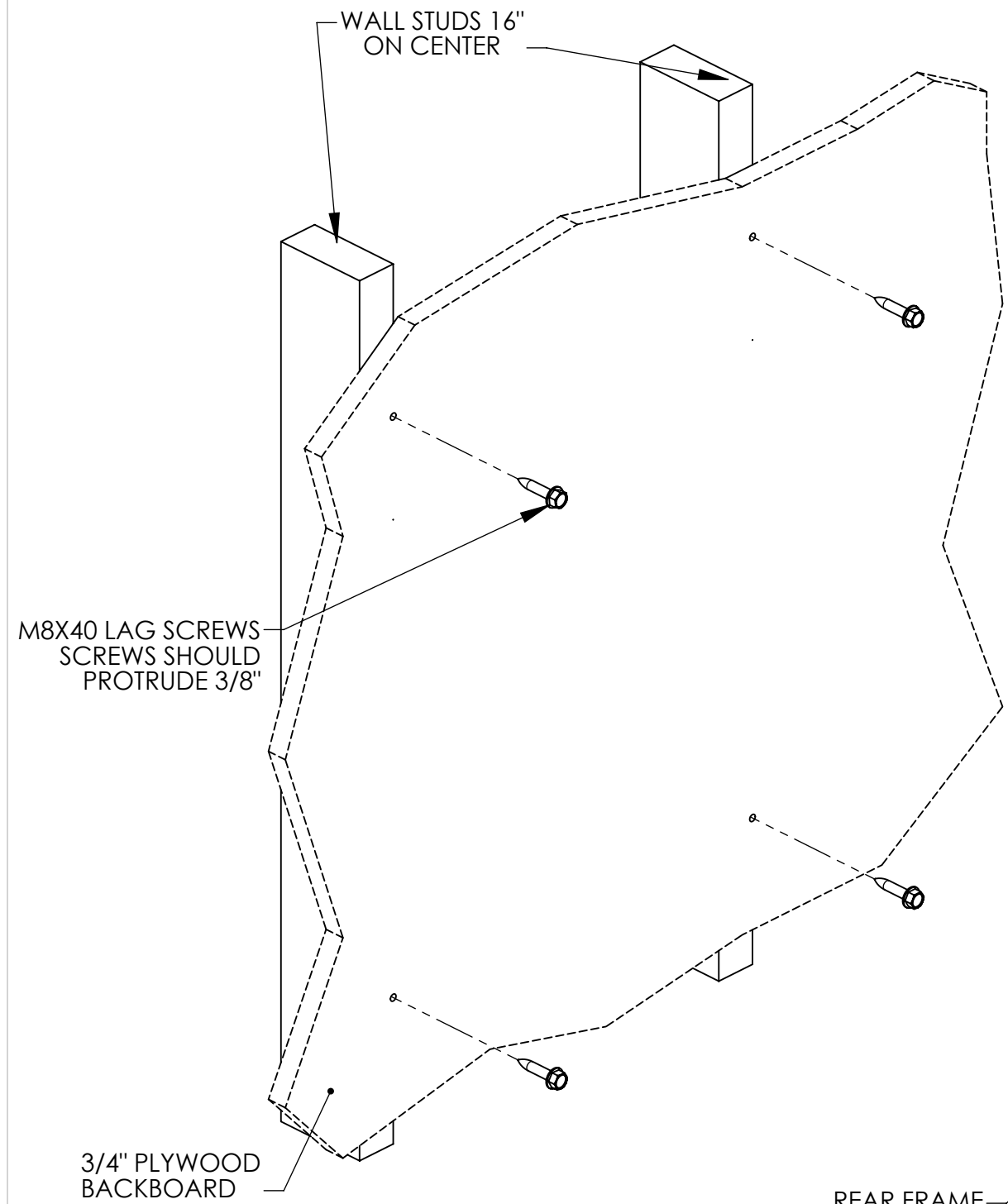

BOLT LOCATIONS
LATERAL: 16.0" ON STUDS
VERTICAL:
 24" CAB: 21.13"
 36" CAB: 33.38"
 48" CAB: 45.63

MOUNTING REAR PANEL TO WALL

- STEP 1. INSURE THAT THE WALL OR MOUNTING SURFACE HAS SUFFICIENT STRENGTH TO SUPPORT THE CABINET AND THE EXPECTED CABINET PAYLOAD. THE MOUNTING SURFACE MUST ALSO BE FLAT AND EXTEND BEYOND THE TOP, BOTTOM, LEFT, AND RIGHT EDGES OF THE REAR PANEL.
- STEP 2. DRILL 5/32" PILOT HOLES FOR THE FOUR M5X40mm LAG SCREWS TO THE DIMENSIONS SHOWN ON THE DRAWING. THE SCREWS SHOULD GO DIRECTLY INTO THE WALL STUDS.
- STEP 3. INSTALL THE LAG SCREWS INTO THE HOLES. THE SCREW HEAD SHOULD PROTRUDE ABOUT 3/8" FROM THE WALL.
- STEP 4. MOUNT THE REAR FRAME TO THE WALL BY HOOKING THE KEYHOLES OVER THE SCREWS. TIGHTEN THE SCREWS SECURELY.
- STEP 5. INSTALL THE REMAINING 2 LAG SCREWS IN THE HOLES BELOW THE TOP TWO KEYHOLES.

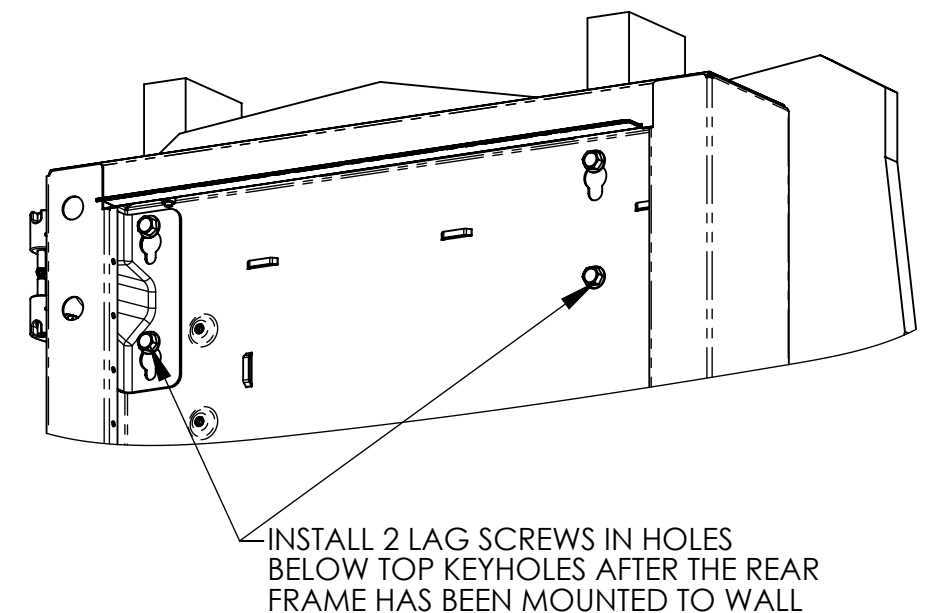

NOTE:

THE REAR FRAME MUST BE SECURED TO WALL USING ALL 6 LAG SCREWS PROVIDED. THE SCREWS ARE INTENDED TO GO THROUGH 3/4" PLYWOOD BACK-BOARD AND THEN INTO WOOD WALL STUDS. FOR MASONRY SURFACE, THE INSTALLER MUST PROVIDE APPROPRIATE HARDWARE.

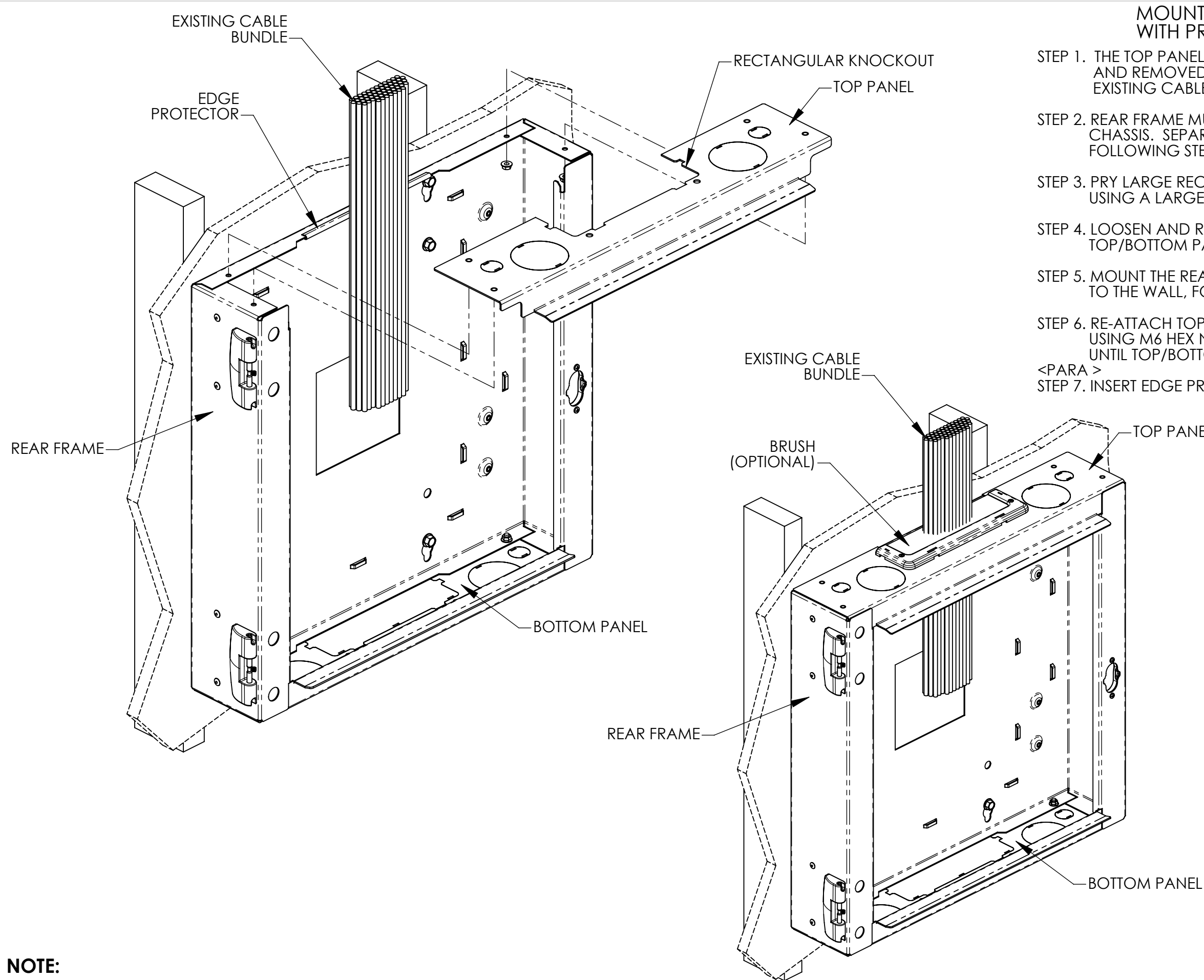

MOUNTING REAR PANEL TO WALL WITH PRE-EXISTING CABLE BUNDLE

- STEP 1. THE TOP PANEL, BOTTOM PANEL OR BOTH CAN BE MODIFIED AND REMOVED DURING INSTALLATION TO ACCOMMODATE EXISTING CABLE BUNDLES
- STEP 2. REAR FRAME MUST BE FIRST SEPARATED FROM THE CENTER CHASSIS. SEPARATE REAR FRAME FROM CENTER CHASSIS BY FOLLOWING STEPS 1-4 ON SHEET 1.
- STEP 3. PRY LARGE RECTANGULAR KNOCKOUT AWAY FROM PANEL USING A LARGE FLAT-HEAD SCREWDRIVER
- STEP 4. LOOSEN AND REMOVE QTY4, M6 HEX NUTS TO SEPARATE TOP/BOTTOM PANEL FROM REAR FRAME.
- STEP 5. MOUNT THE REAR FRAME(SEPARATED FROM CENTER CHASSIS) TO THE WALL, FOLLOWING STEPS 1 THRU 5 ON SHEET 2.
- STEP 6. RE-ATTACH TOP/BOTTOM PANELS TO THE REAR FRAME USING M6 HEX NUTS. DO NOT ATTACH CENTER CHASSIS UNTIL TOP/BOTTOM PANELS HAVE BEEN SECURELY ATTACHED.
- <PARA >
- STEP 7. INSERT EDGE PROTECTOR AND (OPTIONAL) BRUSH

NOTE:

MOUNTING CABINET TO REAR FRAME

- STEP 1. LIFT THE CENTER CHASSIS AND ALIGN HINGES.
- STEP 2. INSERT HINGE PINS INTO BOTH HINGES, UNTIL FULLY SEATED.
- STEP 3. HAND TIGHTEN BOTH SETS SCREWS TO SECURE HINGE PINS INSIDE HINGES.
- STEP 4. CLOSE CABINET BODY AND CLOSE LATCH.

WARNING: FAILURE TO TIGHTEN HINGE SET SCREWS MAY RESULT IN EQUIPMENT DAMAGE, PERSONAL INJURY, OR DEATH

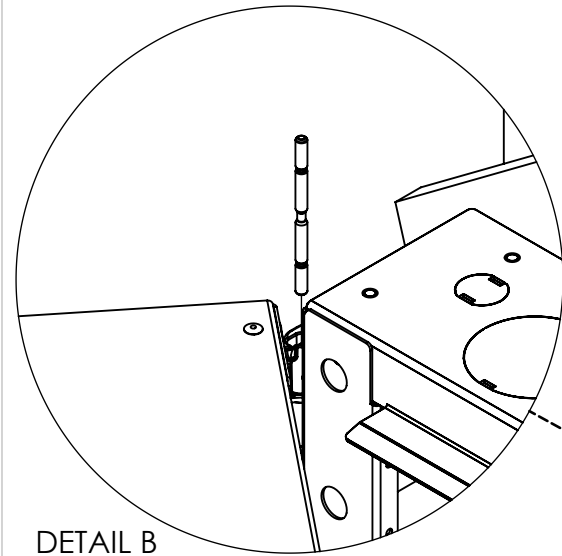

DETAIL B
SCALE 1 : 4

VERIFY SET SCREWS ARE FULLY RECESSED INTO HINGE BODY AND HAVE BEEN TIGHTENED TO SECURE HINGE PINS IN HINGES

CENTER CHASSIS
SIDE

VERIFY HINGES PINS ARE FULLY SEATED INTO HINGES

REAR CHASSIS
SIDE

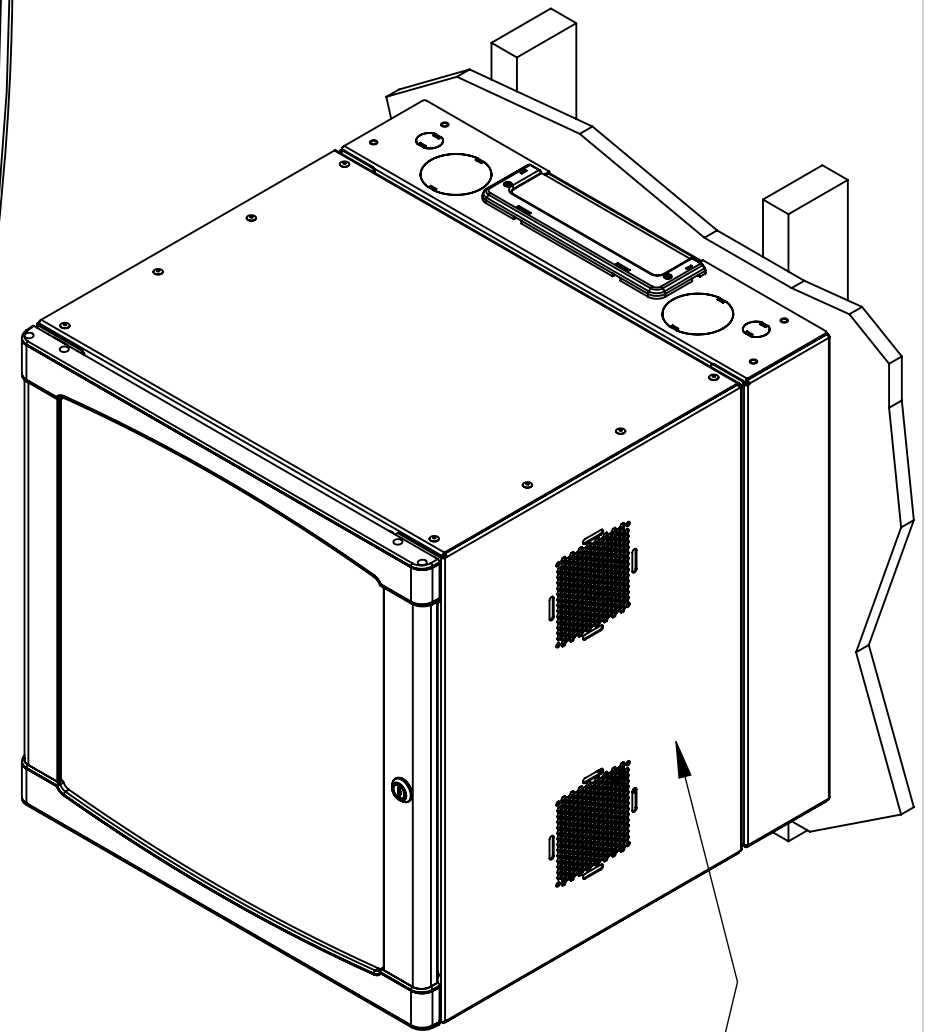
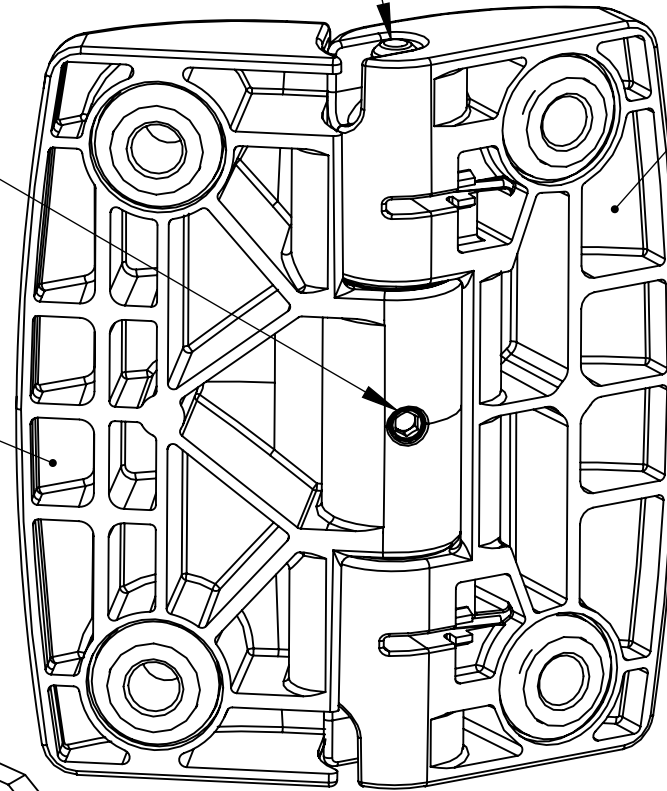
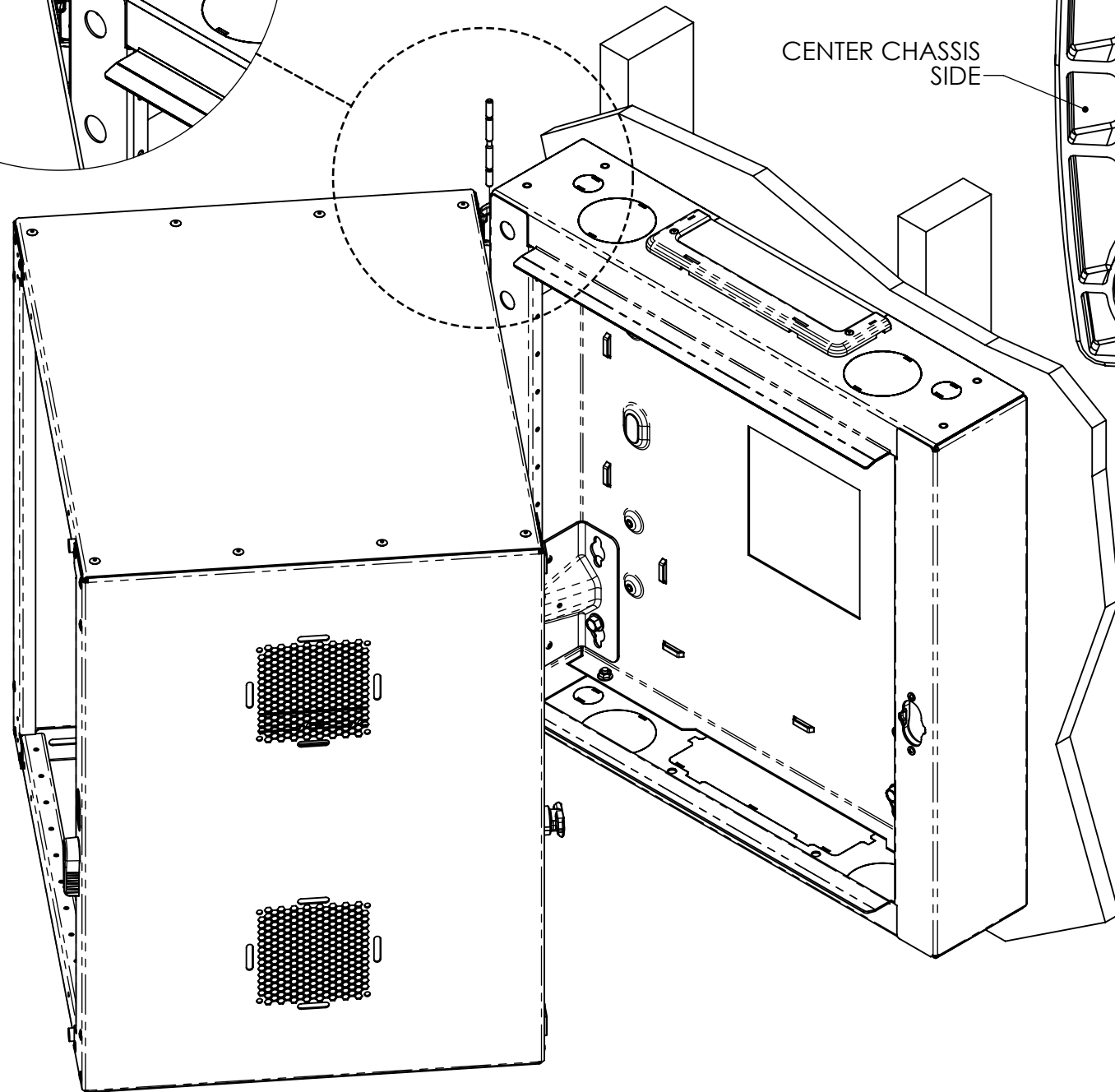

CABINET BODY SHOULD ALWAYS BE CLOSED AND LOCKED EXCEPT WHEN SERVICING.

DO NOT LEAVE CABINET IN OPEN POSITION

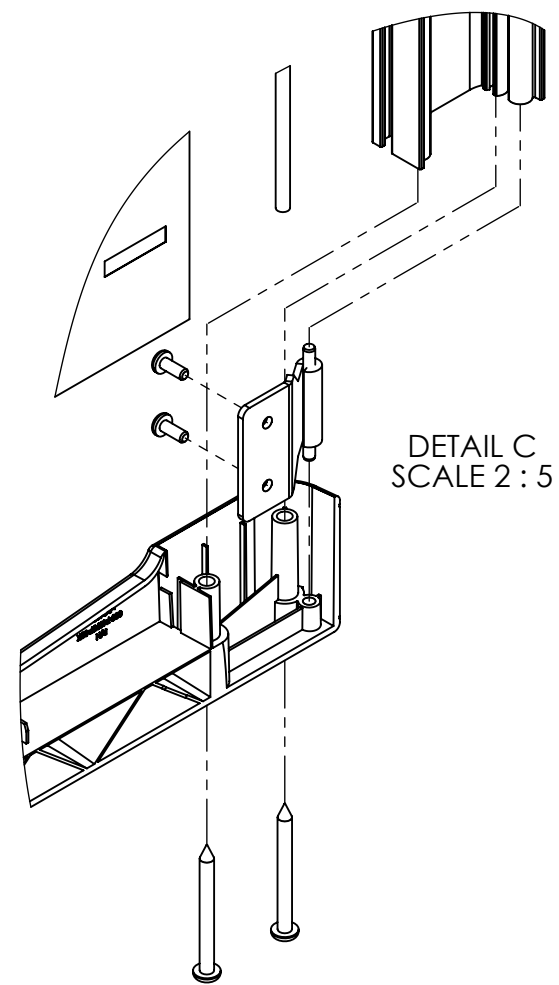
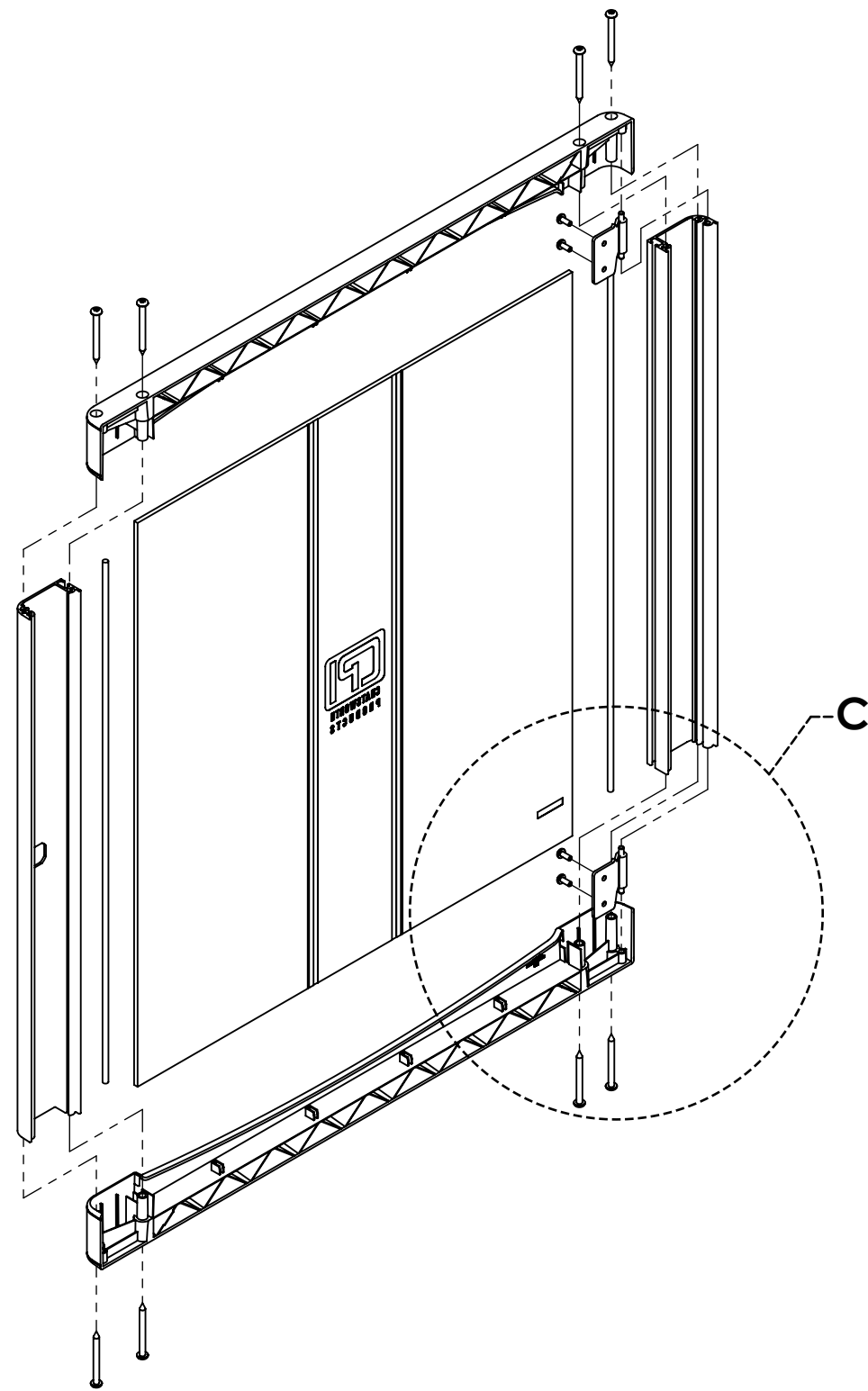

DETAIL C
SCALE 2 : 5

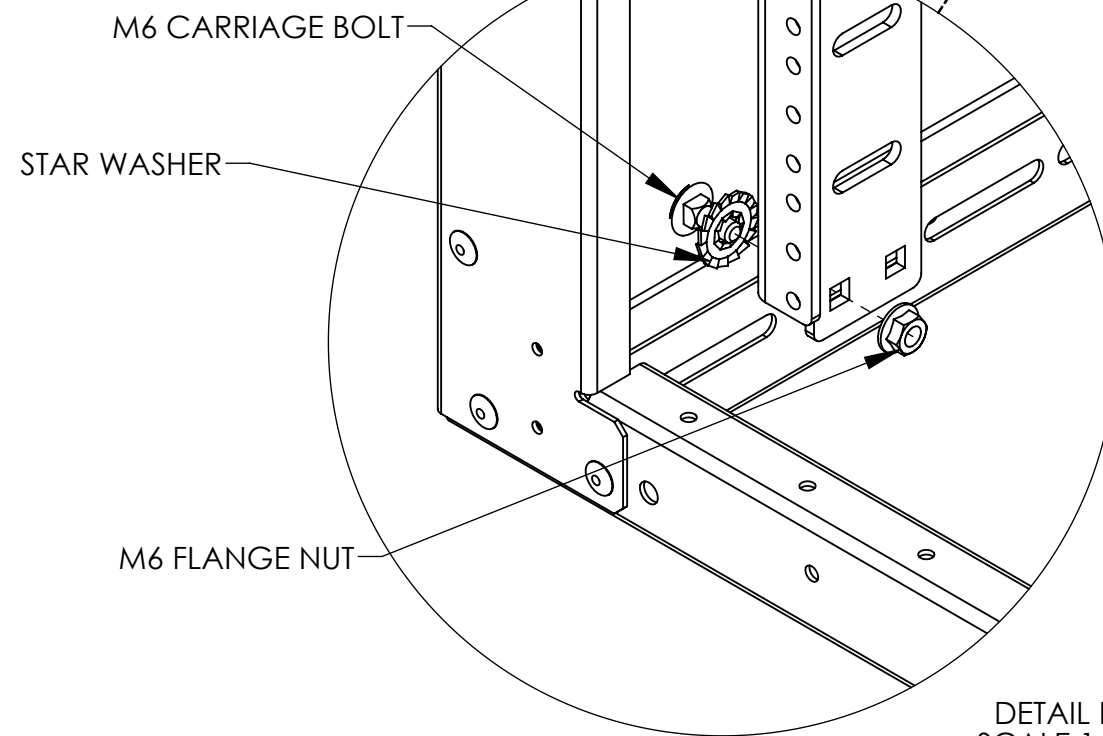
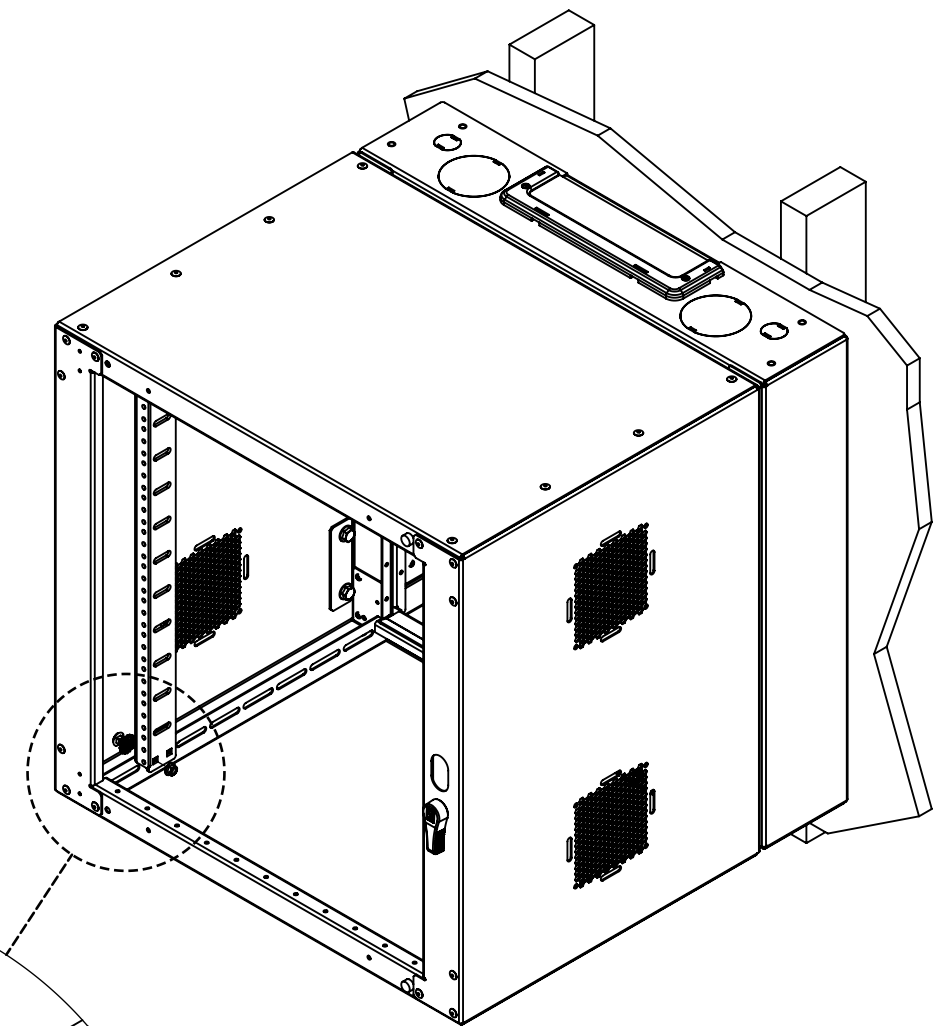

DETAIL D
SCALE 1 : 2

- THE DOOR CAN BE HINGED FROM EITHER SIDE OF THE CABINET.
TO HINGE ON OPPOSITE SIDE:
1. REMOVE THE FOUR SCREWS ATTACHING THE HINGES TO THE CABINET.
 2. REMOVE THE FOUR SCREWS ON THE TOP AND BOTTOM OF THE DOOR.
 3. SLIDE THE TOP AND BOTTOM OFF.
 4. REMOVE GLASS OR METAL CENTER PANEL AND ROTATE 180 DEGREES.
 5. RE-ATTACH TOP AND BOTTOM PIECES USING FOUR SCREWS.
 6. RE-ATTACH DOOR TO CABINET WITH FOUR SCREWS THROUGH THE HINGES ON THE OPPOSITE SIDE.