

---

# **High Speed Positioning System Installation Manual**

**Version 1.0.0**

---

# Table of Contents

<b>1</b>	<b>INSTALLATION PREPARATION</b> .....	<b>1</b>
1.1	Basic Requirement.....	1
1.2	Installation Check.....	1
1.3	Cable Preparation.....	1
1.3.1	The Min Specification Requirements of Cable.....	1
1.3.2	Select Power Supply Cable According to Transmission Distance.....	2
<b>2</b>	<b>INSTALL POSITIONING SYSTEM</b> .....	<b>3</b>
2.1	Check Accessories.....	3
2.2	Open Device.....	3
2.3	Reset Button and Micro SD Card Slot Location.....	3
2.3.1	Use Reset Button.....	5
2.3.2	Install Micro SD Card.....	5
2.4	Camera Cable.....	5
2.4.1	Cable Description.....	5
2.4.2	Cable Connection.....	6
2.4.3	Alarm Cable Connection.....	7
2.4.4	Connect Camera GND Cable.....	7
<b>3</b>	<b>VERTICAL MOUNT</b> .....	<b>8</b>
3.1	Installation Conditions.....	8
3.2	Installation Steps.....	8

---

<b>4</b>	<b>WALL MOUNT VERTICAL INSTALLATION .....</b>	<b>11</b>
4.1	Installation Conditions.....	11
4.2	Installation Steps .....	11
<b>5</b>	<b>WALL MOUNT INVERTED INSTALLATION.....</b>	<b>13</b>
5.1	Installation Conditions.....	13
5.2	Installation Steps .....	13
<b>6</b>	<b>APPENDIX I LIGHTNING PROOF AND SURGE PROTECTION (OUTDOORS)</b>	<b>15</b>
6.1	Lightning Protection (Indoors).....	15
<b>7</b>	<b>APPENDIX II ABOUT RS485 BUS .....</b>	<b>17</b>
7.1	RS485 Bus Main Feature .....	17
7.2	RS485 Bus Transmission Distance .....	17
7.3	The Problem in Practical Use .....	17
7.4	RS485 Bus FAQ .....	18
<b>8</b>	<b>APPENDIX III THE RELATIONSHIP BETWEEN DC 12V CABLE DIAMETER</b>	
	<b>AND TRANSMISSION DISTANCE .....</b>	<b>19</b>
<b>9</b>	<b>APPENDIX IV WIRE GAUGE REFERENCE SHEET .....</b>	<b>20</b>

---

## **Welcome**

Thank you for purchasing our positioning system!

Please read the following safeguards and warnings carefully before you install or use the product!

---

# Important Safeguards and Warnings

## Safety Measures

### 1. Qualified Engineer Needed

- The installation engineer or maintenance engineer shall have corresponding CCTV system installation certificate or maintenance qualification certificate.
- The installation engineer or maintenance engineer shall have qualification certificate for work at height.
- The installation engineer or maintenance engineer shall have the basic knowledge and operation technique for low-voltage cable layout and low-voltage electronic cable connection.
- Please read the installation manual carefully and keep it well for future reference,
- We are not liable for any problems caused by unauthorized modifications or attempted repair.

### 2. Lifting Appliance Requirement

- Please select the proper speed dome installation mode and use the lifting appliances at the safety environment.
- The lifting appliances shall have the enough capacity to reach the installation height.
- The lifting appliances shall have safe performance.

**The precaution measures include two types: Warning and Note.**

- **Warning:** It is to alert you there is an optional risk of death or series injury!
- **Note:** It is to alert you there is an optional risk of damage or property loss!

## Warning

1. All installation and operation here should conform to your local electrical safety codes. We assume no liability or responsibility for all the fires or electrical shock caused by improper handling or installation.
2. Do not connect several speed domes to one power adapter. It may result in overheat or fire if it exceeds the rated load.
3. Before you connect the cable, install or uninstall, or begin the daily maintenance work, please turn off the power and unplug the power cable.
4. Please make sure the product is secured firmly on the wall or the ceiling.
5. Please turn off the power and unplug the power cable, If there is any smoke, disgusting smell, or noise. Please contact your local retailer or customer service center for help.

- 
6. All the examination and repair work should be done by the qualified service engineers. We are not liable for any problems caused by unauthorized modifications or attempted repair.

## Note

### 1. Safety Transportation

- Heavy stress, violent vibration or water splash are not allowed during transportation, storage and installation.
- This series product must use split type package during the transportation.
- We are not liable for any damage or problem resulting from the integrated package during the transportation.

### 2. When device is malfunction

Shut down the device and disconnect the power cable immediately if there is smoke, abnormal smell or abnormal function. Please contact your local retailer ASAP.

### 3. Do not try to dismantle or modify the device

- There is risk of personal injury or device damage resulting from opening the shell.
- Please contact your local retailer if there is internal setup or maintenance requirement.
- We are not liable for any problems caused by unauthorized modifications or attempted repair.

### 4. Do not allow other object falling into the device

- Please make sure there is no metal or inflammable, explosive substance in the speed dome.
- The above mentioned objects in the device may result in fire, short-circuit or damage.
- Please shut down the device and disconnect the power cable if there is water or liquid falling into the camera. Please contact your local retailer ASAP.
- Please pay attention to the camera. Avoid the sea water or rain to erode the camera.

### 5. Handle carefully

Do not allow this series product fall down to the ground.  
Avoid heavy vibration.

### 6. Installation Environment Requirement

- This series speed dome should be installed in a cool, dry place away from direct sunlight, inflammable, explosive substances and etc.
- This series product shall be away from the strong electromagnetism radiant, please keep it away from wireless power, TV transmitter, transformer and etc.

### 7. Daily Maintenance

- Please use the soft cloth to clean dust on the shell, or you can use soft cloth with cleaning liquid to clean the shell and then use soft cloth to make it dry.

- 
- Do not use gasoline, dope thinner or other chemical material to clean the shell. It may result in shell transfiguration or paint flake.
  - Do not allow the plastic or rubber material to touch the shell for a long time. It may result in paint flake.
  - It is highly recommended to use the product with a lightning-proof device, which can realize better lightning-proof effect.

---

# 1 Installation Preparation

## 1.1 Basic Requirement

- All installation and operation here should conform to your local electrical safety code, fire protection regulations and other relevant regulations.
- Make sure the application scene of the camera meets the installation requirements. Please contact dealer if you have any confusions.
- Please use the product according to the operating environment.
- Please keep the original packing materials properly after opening the package. Please pack the camera with original packing materials and send it back for maintenance if anything happens to the product.

## 1.2 Installation Check

- Please make sure the installation environment has enough space to install the product and its mounting structure components.
- Please make sure the ceiling or wall can sustain 8X weight of the camera and corresponding mounting structure components.
- Please make sure the wall is thick enough to install expansion bolts (users need to prepare by themselves).
- It needs to pay attention that the installation height is required to be more than 6m if it is an intelligent tracking device or laser speed dome.

## 1.3 Cable Preparation

Please select the min specification requirement of cable and video coaxial cable according to the transmission distance.

### 1.3.1 The Min Specification Requirements of Cable

- 75 ohm impedance.
- Full cable with copper conductor
- 95% knitted copper shield
- RS485 communication cable, refer to appendix 2 for more details.

Please refer to Table 1-1 for the relations between cable model and transmission distance.

International Model	Max Distance (Ft/M)
RG59/U	750ft (229m)
RG6/U	1,000ft (305m)
RG11/U	1,500ft (457m)

Table 1-1

#### Note

The above can be applied to network speed dome.



---

### 1.3.2 Select Power Supply Cable According to Transmission Distance

Refer to appendix 3 for DC 12V power supply device.

Refer to Table 1-2 for the cable specification of PoE power supply device.

<b>POE Specification</b>	<b>Cable Specification</b>
AF	CAT4 and higher
AT	CAT5 and higher
HiPOE or BT	CAT5E and higher

Table 1-2

The device is AT standard, the cable specification is required to be higher than CAT5.

---

## 2 Install Positioning System

### 2.1 Check Accessories

Before installation, please check the accessories one by one according to the packing list. Please make sure all the components listed are included.

### 2.2 Open Device

Please open the box and then take out the device, the device appearance is shown in Figure 2-1.

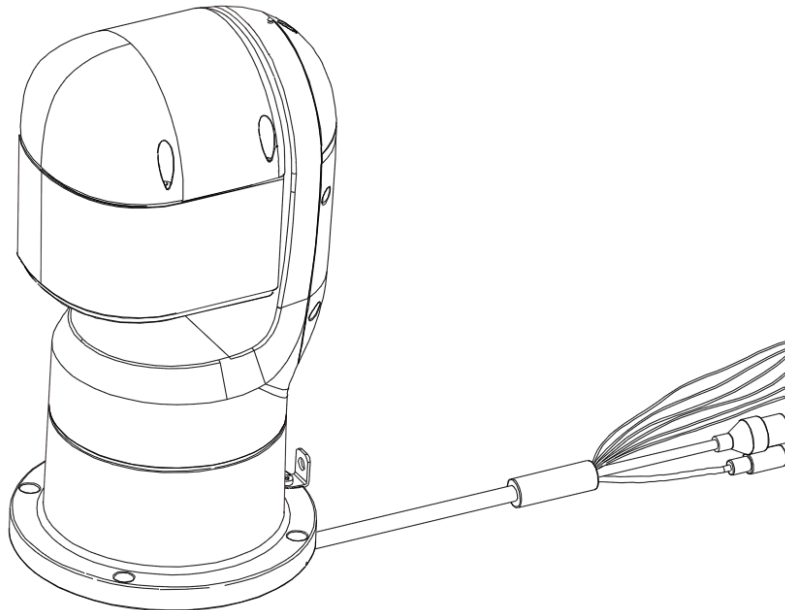

Figure 2-1

### 2.3 Reset Button and Micro SD Card Slot Location

Loosen the screws on the rear cover of the camera, open the camera enclosure and you can see reset button and Micro SD card slot, which is shown in Figure 2-2.

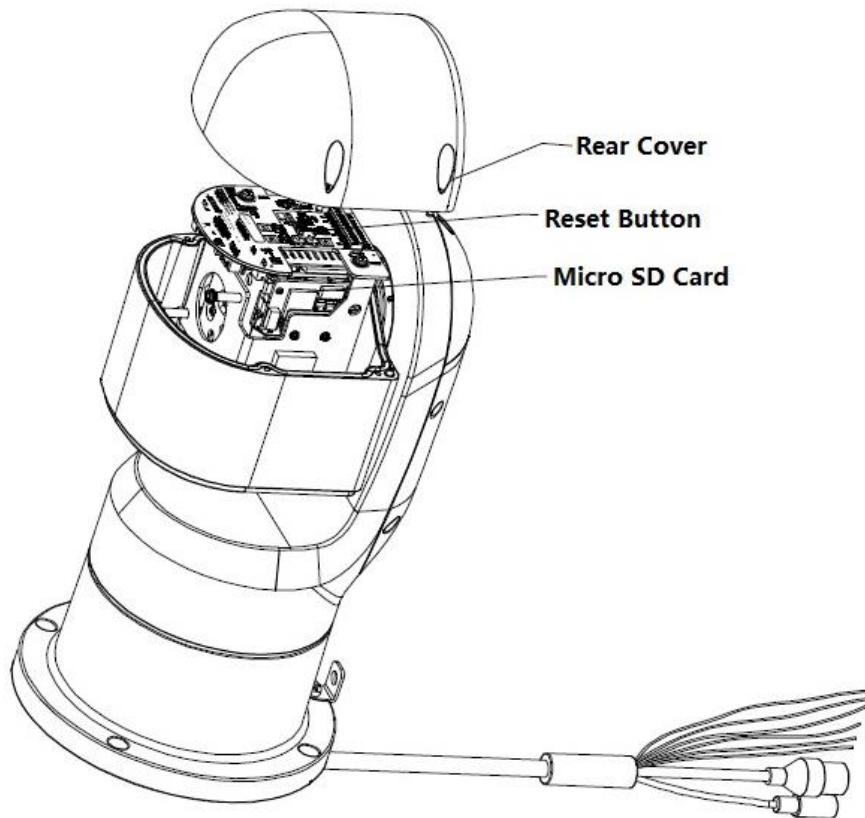

Figure 2-2

The reset button is located on the main control board of the camera, which is shown in Figure 2-3.

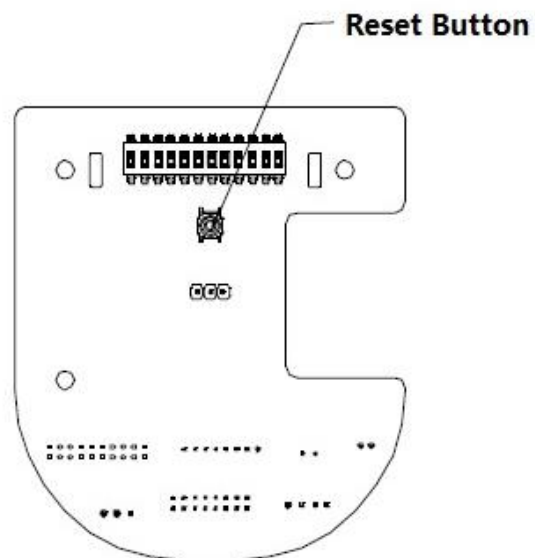

Figure 2-3

The Micro SD card slot is located above the camera module, which is shown in Figure 2-4.

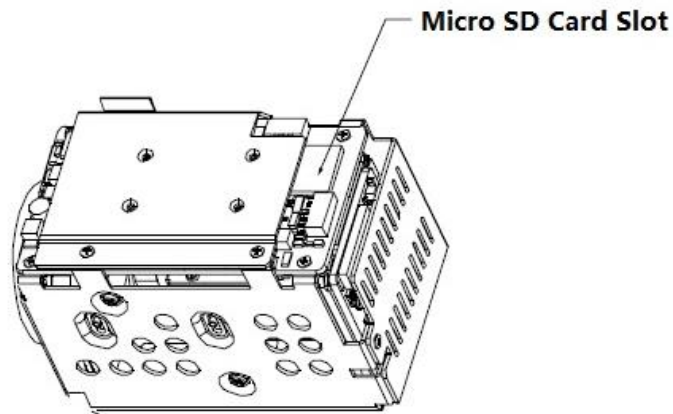

Figure 2-4

### 2.3.1 Use Reset Button

Long press the reset button (more than 10s) to reset the device.

### 2.3.2 Install Micro SD Card

Micro SD card is used for data storage.

Make the side with metal contact of the Micro SD card face downward, (pay attention to the direction of inserting Micro SD card) insert it into the slot.

#### **Note**

Push the SD card according to the direction where the card is inserted, and the card will pop out automatically.

## 2.4 Camera Cable

### 2.4.1 Cable Description

The camera is equipped with a multi-functional combination cable by default, which includes power cable, video cable, RS485 control cable, alarm cable, network cable, and audio cable etc. The cable detail is shown in Figure 2-5.

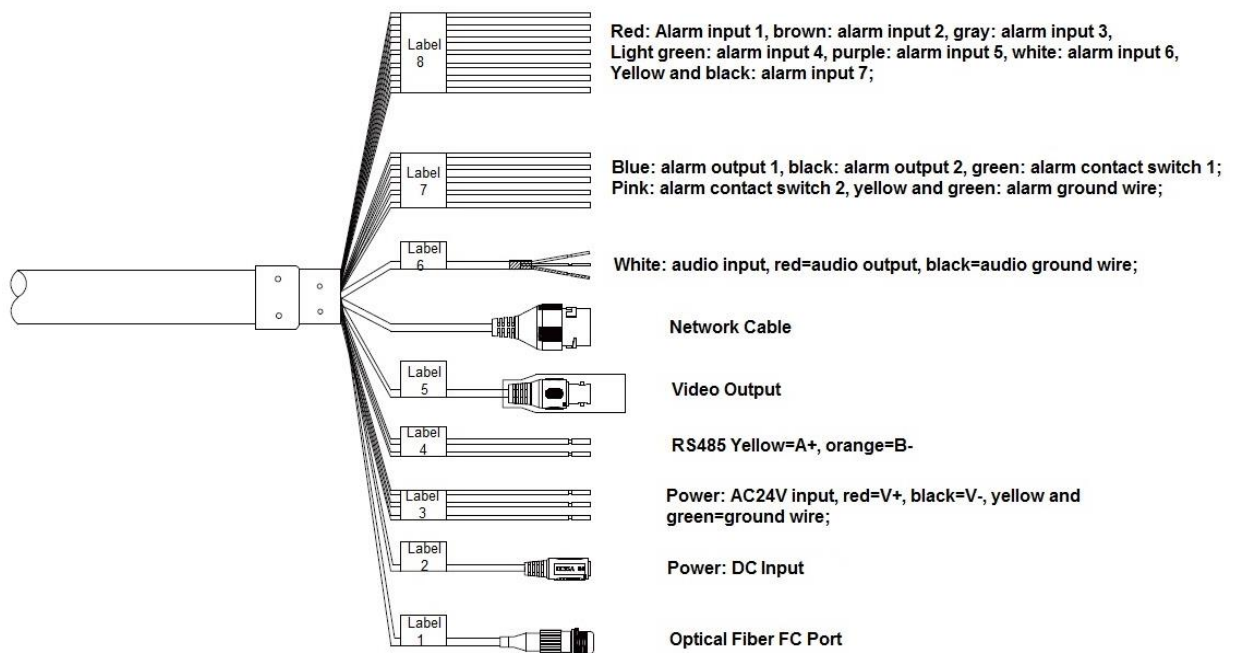

Figure 2-5

**Note**

Different models have different cable combinations, please refer to the actual cable combination for more details. The cable combination is the most comprehensive example shown in the figure above.

It is prohibited to pull the cable to lift the speed dome when moving the device, the wrong way of carrying device is shown in Figure 2-6.

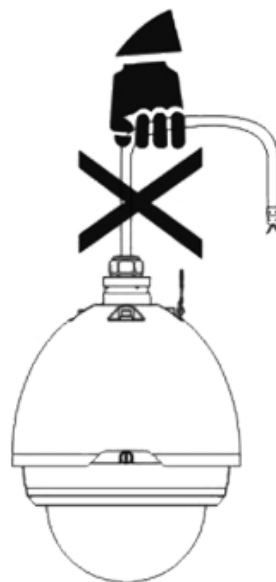

Figure 2-6

**2.4.2 Cable Connection**

Connect cable which is pulled out of wall to the corresponding power cable, video cable, audio cable, RS-485 control cable, alarm cable, network cable, high frequency cable and optical fiber

---

cable etc. (according to the actual requirements) of the multi-functional combination cable, and then twine the cable connector with insulated tape to make it waterproof.

**Note**

- During actual installation, make sure the wire diameter of the cable which is to connect to RS485 control cable can't be too big, otherwise it will affect the control effect. Please refer to appendix 2 RS485 bus for relevant introduction.
- The video port is covered with the heat shrink tube of high shrinking ratio. After the video port is well connected, please heat the tube to make sure the video port is damp proof and water proof.

### **2.4.3 Alarm Cable Connection**

The alarm cable connection mode and config steps are shown as follows:

**Step 1**

Connect alarm input device to the ALARM IN and ALARM GND of the user cable.

**Step 2**

Connect alarm output device to the ALARM OUT and ALARM COM of the user cable, alarm output is the relay switch output.

**Step 3**

Open the device WEB interface, make corresponding settings to the alarm input and output device in "Setup > Event > Alarm Setup". The alarm input of WEB is corresponding to the alarm input of the user cable. It is to set the corresponding NO and NC output according to the high and low level signal generated by alarm input device when alarm triggers.

**Step 4**

Set the alarm output situation of user cable on the WEB.

### **2.4.4 Connect Camera GND Cable**

Connect the power line YELLOW & GREEN of the combination cable to the lightning protection device, and make sure the lightning protection device is well grounded.

---

## 3 Vertical Mount

### 3.1 Installation Conditions

The camera needs to be installed on hard platform in both indoor and outdoor environments. The platform needs to meet the following installation conditions:

- The platform shall be thick enough to install expansion bolts.
- The platform area needs to be bigger than that of the camera pedestal.
- The platform needs to sustain at least 8X weight of the camera and bracket etc.

### 3.2 Installation Steps

The installation steps are shown as follows:

#### Step 1

Take the mounting holes of wall-mounted bracket bottom as template, select mounting location around the threading holes. Draw the punch positions on the mounting platform and dig holes, then pre-bury the expansion bolts into the holes which have been dug, which is shown in Figure 3-1.

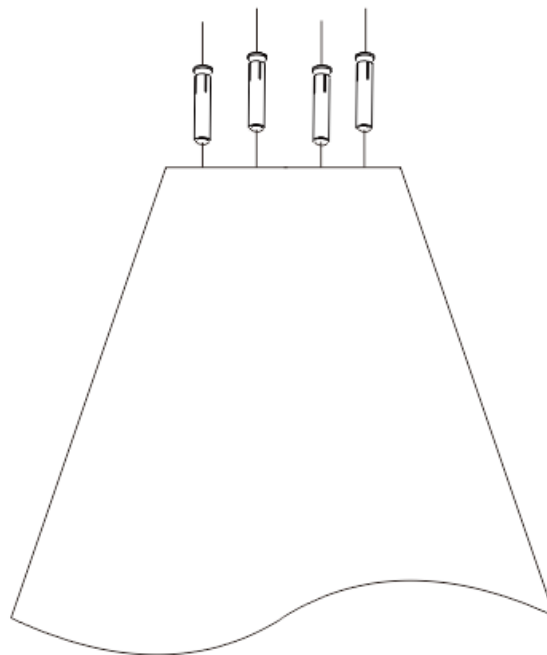

Figure 3-1

#### Step 2

Use four screws to fix the junction box on the mounting platform, which is shown in Figure 3-2.

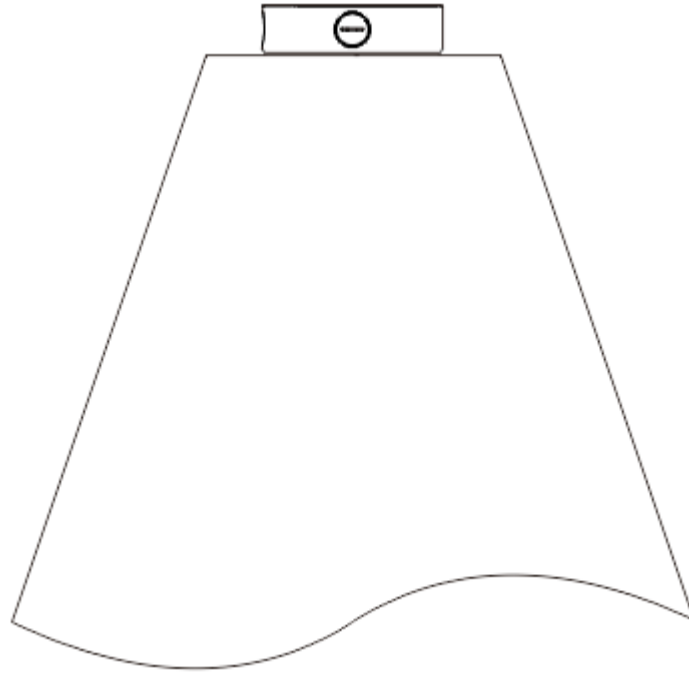

Figure 3-2

**Step 3**

Place the camera on the junction box after connecting camera cable to table-board cable (please be aware that the groove of camera pedestal shall be aligned with the convex on the junction box).

**Step 4**

Use screws to fix the camera on the junction box and then the camera is completely installed, which is shown in Figure 3-3.



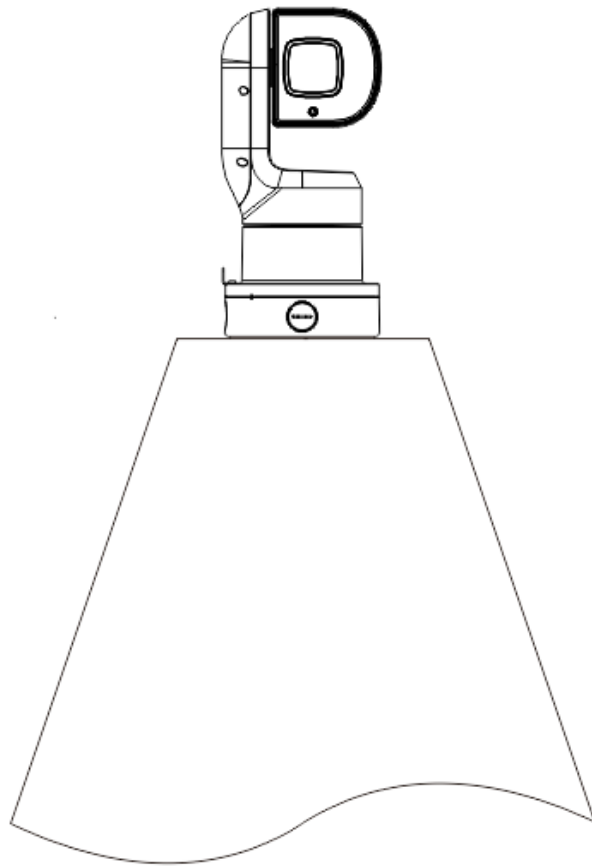

Figure 3-3

---

## 4 Wall Mount Vertical Installation

### 4.1 Installation Conditions

The camera needs to be installed on hard wall structure in both indoor and outdoor environments.

The wall needs to meet the following installation conditions:

- The wall shall be thick enough to install expansion bolts.
- The wall shall sustain at least 8X weight of the camera and bracket etc.

### 4.2 Installation Steps

#### Step 1

Take the mounting holes of wall-mounted bracket bottom as template, mark the punch positions on the wall and dig holes, then pre-bury the expansion bolts into the hole which have been dug, which is shown in Figure 4-1.

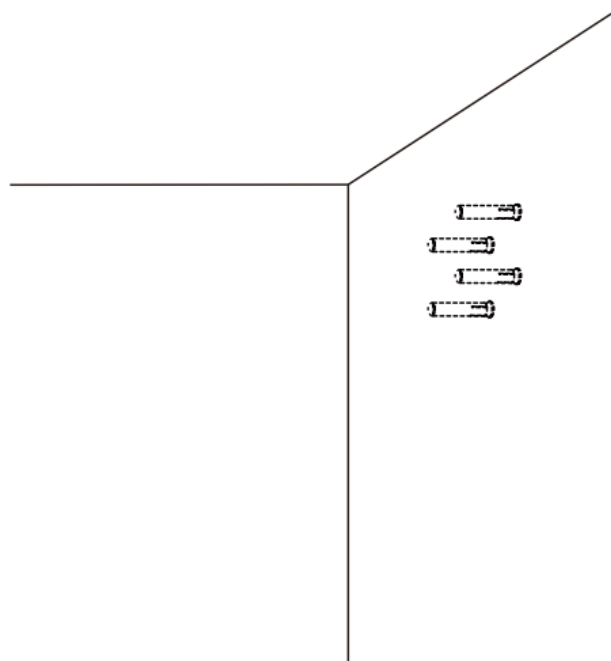

Figure 4-1

#### Step 2

Put the camera cable into the bracket, use screws to fix the camera on the bracket and buckle the safety rope well, which is shown in Figure 4-2.

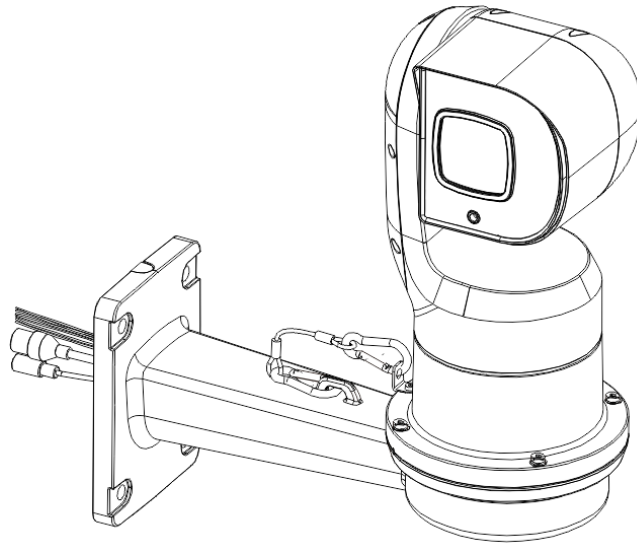

Figure 4-2

**Step 3**

Connect the camera cable to wall cable.

**Step 4**

Lift the camera and bracket to the same altitude as the mounting holes on the wall, use flat gasket and four hex nuts to fix it on the wall. So far, the camera has been completely installed, which is shown in Figure 4-3.

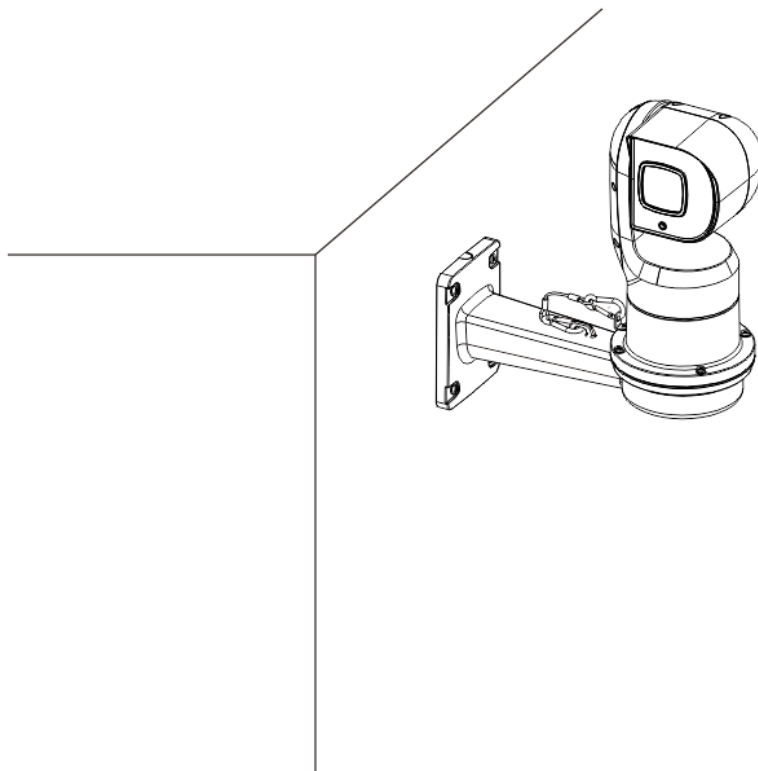

Figure 4-3

---

## 5 Wall Mount Inverted Installation

### 5.1 Installation Conditions

The camera needs to be installed on hard wall structure in both indoor and outdoor environments. The wall needs to meet the following installation conditions:

- The wall shall be thick enough to install expansion bolts.
- The wall shall sustain at least 8X weight of the camera and bracket etc.

### 5.2 Installation Steps

#### Step 1

Take the mounting holes of wall-mounted bracket bottom as template, mark the punch positions on the wall and dig holes, then pre-bury the expansion bolts into the hole which have been dug. Use flat gasket and four hex nuts to twist the bracket into the pre-buried expansion bolts, which is shown in Figure 5-1.

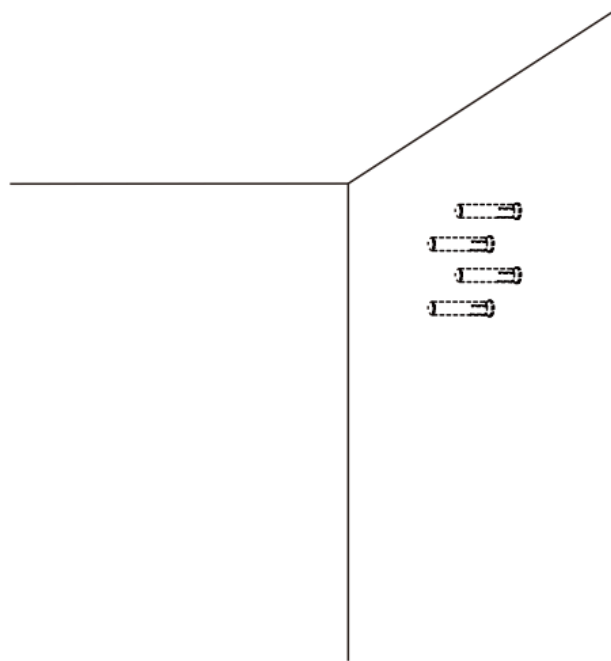

Figure 5-1

#### Step 2

Put the camera cable into the bracket, use screws to fix the camera on the bracket and buckle the safety rope well, which is shown in Figure 5-2.

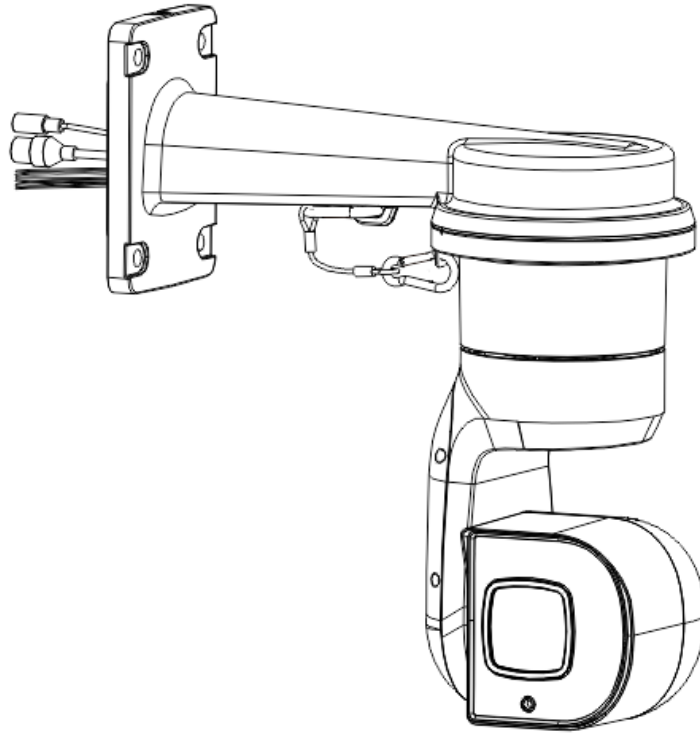

Figure 5-2

**Step 3**

Connect camera cable to the wall cable.

**Step 4**

Lift the camera and bracket to the same altitude of the mounting holes on the wall, use flat gasket and four hex nuts to fix it on the wall. So far, the camera has been completely installed, which is shown in Figure 5-3.

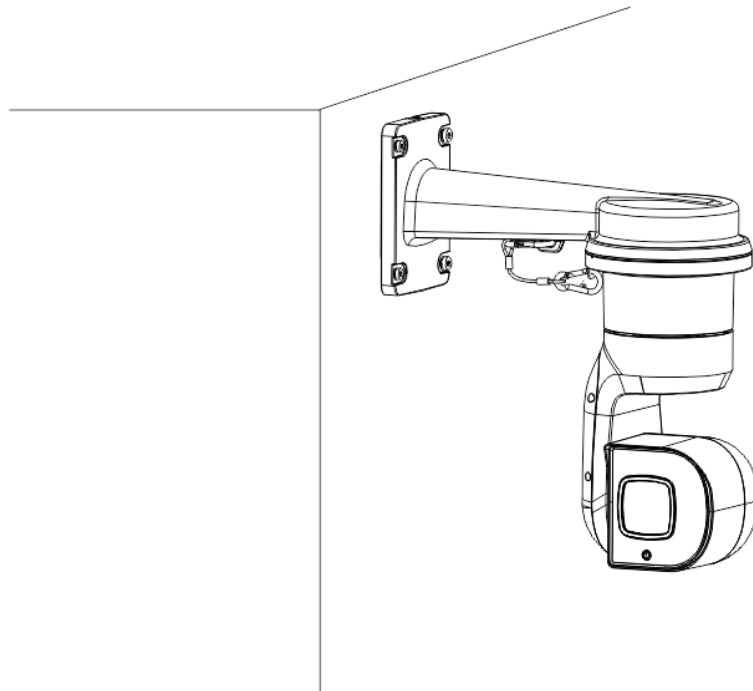

Figure 5-3

## 6 APPENDIX I LIGHTNING PROOF AND SURGE

### PROTECTION (Outdoors)

This series speed dome adopts TVS lightning protection technology. It can effectively prevent damages from various pulse signals below 6000W, such as sudden lightning and surge. While maintaining your local electrical safety code, you still need to take necessary precaution measures when installing the speed dome in the outdoor environment.

- The distance between the signal transmission cable and high-voltage device (or high-voltage cable) shall be at least 50 meters.
- Outdoor cable layout shall go under the penthouse if possible.
- For vast land, please use sealing steel tube under the land to implement cable layout and connects one point to the earth. Open floor cable layout is forbidden.
- In area of strong thunderstorm hit or near high sensitive voltage (such as near high-voltage transformer substation), you need to install additional high-power thunder protection device or lightning rod.
- The thunder protection and earth of the outdoor device and cable shall be considered in the building whole thunder protection and conform to your local national or industry standard.
- System shall adopt equal-potential wiring. The earth device shall meet anti-jamming and at the same time conforms to your local electrical safety code. The earth device shall not short circuit to N (neutral) line of high voltage power grid or mixed with other wires. When connect the system to the earth alone, the earth resistance shall not be more than  $4\ \Omega$  and earth cable cross-sectional area shall be no less than  $25\ \text{mm}^2$ . See Figure 6-1.

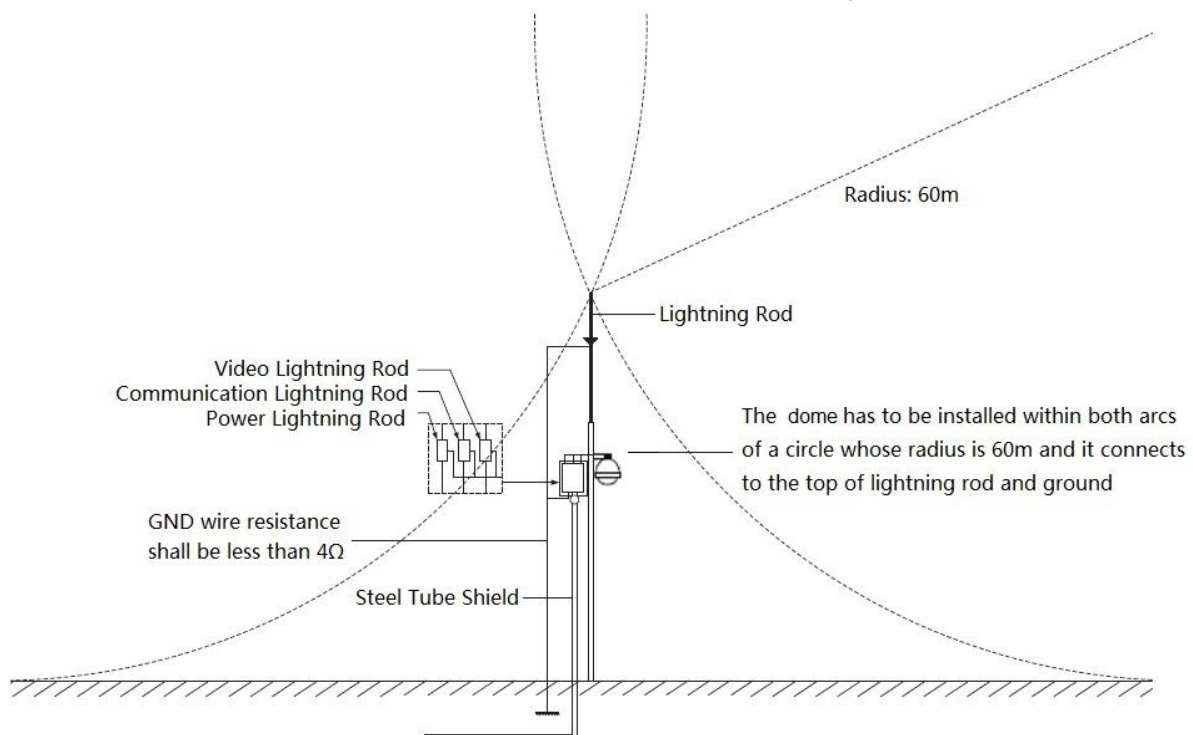

Figure 6-1

### 6.1 Lightning Protection (Indoors)

---

The yellow and green GND wire or GND screw of the speed dome should be reliably connected by several strands of copper wire with no less than 25mm<sup>2</sup> and indoor equipotential GND terminal. Please refer to Figure 6-2 for lightningproof installation mode.

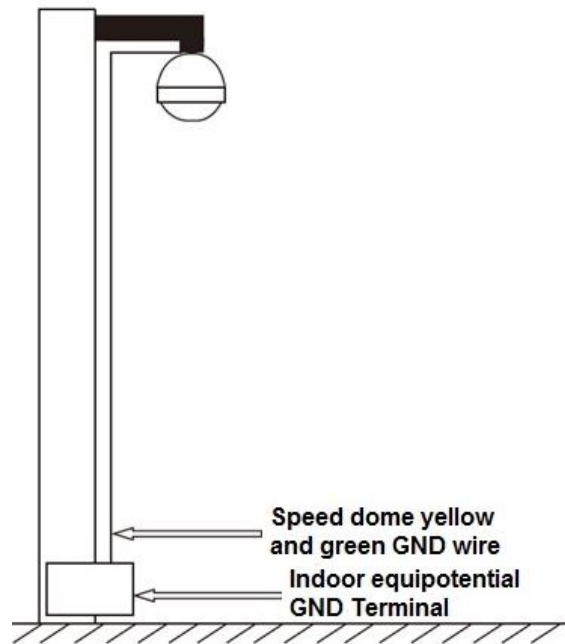

Figure 6-2

---

## 7 APPENDIX II ABOUT RS485 BUS

### 7.1 RS485 Bus Main Feature

RS485 is semi duplex communication cable of impedance  $120\ \Omega$  . Its max load amount is 32 effective loads (including main control device and devices to be charged).

### 7.2 RS485 Bus Transmission Distance

When we take 0.56mm (24AWG) twisted-pair as communication cable, the max transmission distance (theoretically) are listed below (according to different baud rates).

Baud Rate	Max Distance
2400 BPS	1800M
4800 BPS	1200M
9600 BPS	800M

In the following situations, the max transmission distance shall become shorter accordingly:

- The communication cable is a little bit thin;
- The surrounding environment has strong electromagnetic interference;
- There are too much devices connected to the RS485 bus;

And vice versa, the max transmission distance shall become longer.

### 7.3 The Problem in Practical Use

In practical usage, we usually adopt star type connection. The terminal resistance shall connect to the furthest two devices (Such as device 1# and device 15# in Figure 7-1). But this connection way does not conform to RS485 Bus standard. When the distances between devices are too long, the signal reflection occurs and anti-jamming decreases, thus the signal reliability becomes very low. You can see speed dome is not under control or speed dome is running automatically and cannot stop.

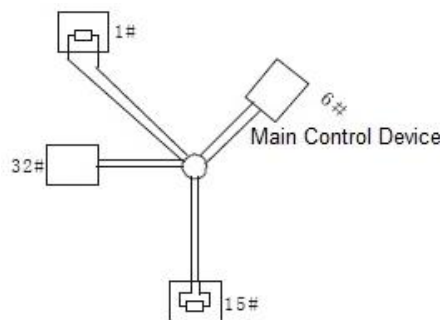

Figure 7-1

In this situation, we recommend RS485 distributor. This device can turn star type connection into the connection that conforms to RS485 bus industry standard, which can avoid the above mentioned problems and enhance communication reliability. See Figure 7-2.



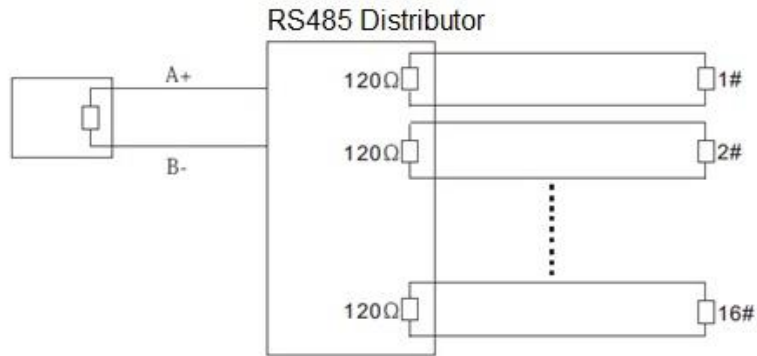

Figure 7-2

## 7.4 RS485 Bus FAQ

Phenomenon	Possible Reasons	Solution
Speed dome can run self-diagnosis but I cannot control it.	<ul style="list-style-type: none"> <li>● Host address(baud rate) and speed dome address(baud rate) are not match;</li> <li>● Positive and negative end of RS485 Bus are misconnected;</li> <li>● Connection cable is loose;</li> <li>● RS485 Bus connection are cut off;</li> </ul>	<ul style="list-style-type: none"> <li>● Modify host or speed dome setup ;</li> <li>● Switch RS485 positive end and negative end;</li> <li>● Fix connection cable firmly;</li> <li>● Replace RS485 Bus.</li> </ul>
I can control the speed dome but is not smooth	<ul style="list-style-type: none"> <li>● RS485 Bus connection are not good;</li> <li>● One RS485 bus is off;</li> <li>● The distance between host and speed dome is too far;</li> <li>● Parallel connected too much speed domes.</li> </ul>	<ul style="list-style-type: none"> <li>● Connect RS 485 Bus again;</li> <li>● Replace RS485 Bus;</li> <li>● Add terminal matching resistance;</li> <li>● Add RS485 distributor.</li> </ul>

## 8 APPENDIX III THE RELATIONSHIP BETWEEN DC 12V CABLE DIAMETER AND TRANSMISSION DISTANCE

It is the recommended max transmission distance when the cable diameter is fixed and the DC 12V power consumption is below 10%. For the DC power supply devices, the max allowed voltage loss rate is 10%. The cable listed in the table below is copper wire (the resistivity of copper is  $\rho=0.0175\Omega\cdot\text{mm}^2/\text{m}$ ).

w	mm	0.8000	1.000	1.250	2.000
	Feet(m)				
5		122.13 (37.23)	190.83 (58.16)	298.17 (90.88)	763.31 (232.66)
10		61.06 (18.61)	95.41 (29.08)	149.08 (45.44)	381.66 (116.33)
15		40.71 (12.41)	63.61 (19.39)	99.39 (30.29)	254.44 (77.55)
20		30.53 (9.31)	47.71 (14.54)	74.54 (22.72)	190.83 (58.16)
25		24.43 (7.45)	38.17 (11.63)	59.63 (18.18)	152.66 (46.53)
30		20.35 (6.20)	31.80 (9.69)	49.69 (15.15)	127.22 (38.78)
35		17.45 (5.32)	27.26 (8.31)	42.60 (12.98)	109.04 (33.24)
40		15.27 (4.65)	23.85 (7.27)	37.27 (11.36)	95.41 (29.08)
45		13.57 (4.14)	21.20 (6.46)	33.13 (10.10)	84.81 (28.85)
50		12.21 (3.72)	19.08 (5.82)	29.82 (9.09)	76.33 (23.27)
55		11.10 (3.38)	17.35 (5.29)	27.11 (8.26)	69.39 (21.15)
60		10.18 (3.10)	15.90 (4.85)	24.85 (7.57)	63.61 (19.39)
65		9.39 (2.86)	14.68 (4.47)	22.94 (6.99)	58.72 (17.90)
70		8.72 (2.66)	13.63 (4.15)	21.30 (6.49)	54.52 (16.62)
75		8.14 (2.48)	12.72 (3.88)	19.88 (6.06)	50.89 (15.51)
80		7.63 (2.33)	11.93 (3.64)	18.64 (5.68)	47.71 (14.54)
85		7.18 (2.19)	11.23 (3.42)	17.54 (5.35)	44.90 (13.69)
90		6.78 (2.07)	10.60 (3.23)	16.56 (5.05)	42.41 (12.93)
95		6.43 (1.96)	10.04 (3.06)	15.69 (4.78)	40.17 (12.25)
100		6.11 (1.86)	9.54 (2.91)	14.91 (4.54)	38.17 (11.63)

## 9 APPENDIX IV WIRE GAUGE REFERENCE SHEET

Metric bare wire diameter (mm)	AWG	SWG	Bare wire cross section (mm <sup>2</sup> )
0.050	43	47	0.00196
0.060	42	46	0.00283
0.070	41	45	0.00385
0.080	40	44	0.00503
0.090	39	43	0.00636
0.100	38	42	0.00785
0.110	37	41	0.00950
0.130	36	39	0.01327
0.140	35	/	0.01539
0.160	34	37	0.02011
0.180	33	/	0.02545
0.200	32	35	0.03142
0.230	31	/	0.04115
0.250	30	33	0.04909
0.290	29	31	0.06605
0.330	28	30	0.08553
0.350	27	29	0.09621
0.400	26	28	0.1257
0.450	25	/	0.1602
0.560	24	24	0.2463
0.600	23	23	0.2827
0.710	22	22	0.3958
0.750	21	/	0.4417
0.800	20	21	0.5027
0.900	19	20	0.6362
1.000	18	19	0.7854
1.250	16	18	1.2266
1.500	15	/	1.7663
2.000	12	14	3.1420
2.500	/	/	4.9080
3.000	/	/	7.0683

### Note

- This manual is for reference only. Slight difference may be found in the user interface.
- All the designs and software here are subject to change without prior written notice.
- All trademarks and registered trademarks are the properties of their respective owners.
- If there is any uncertainty or controversy, please refer to the final explanation of us.
- Please visit our website or contact your local service engineer for more information.