

## Openpath Embedded USB Smart Reader

The Openpath Embedded USB Smart Reader combines the functionality of a USB printer reader, desktop enrollment reader, and embedded module into one device. This multi-technology reader supports both low (125 kHz) and high (13.56 MHz) frequencies. The reader can be installed on a single gang box, embedded into a wall for an architectural application, installed inside turnstiles and elevators, or used at a desk or printer. Choose between using the RS-485 terminal block or the USB port depending on your configuration.

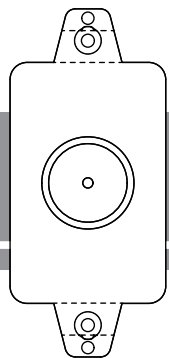

Removable tabs to accommodate any installation type

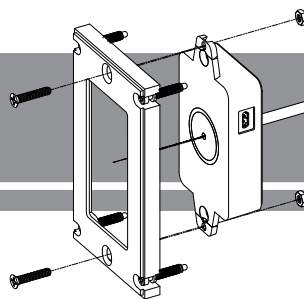

Architectural installation

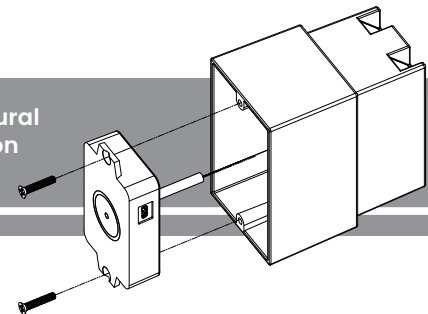

Gang box installation

## Openpath Access

Openpath creates smart security solutions for the modern office. The company's flagship product, Openpath Access, combines sleek hardware with an app, enabling employees to enter the office using their smartphone. Unlike legacy systems, Openpath's software is cloud-based, meaning Access easily scales with your business and seamlessly integrates with platforms like G Suite and Azure AD.

Openpath's patented SurePath Mobile technology ensures reliability and quick entry via Bluetooth, Wi-Fi and LTE\*. With encryption at every level and powerful, user-level permissions, Openpath Access is both more secure and more dynamic than traditional access control systems. Openpath Access' streamlined, customizable features make office management easier than ever.

\*Embedded USB Readers connected to USB will only accept any non-mobile credential at this time.





## Embedded Smart Reader

### Card Compatibility

- Openpath DESFire EV3
- MIFARE Classic/DESFire/Ultralight (ISO14443A) CSN
- Openpath Proximity
- HID® Proximity
- LenelProx®

### Specifications

Cloud Managed	Yes
Form	Mini
Color	Black
Frequency	125 kHz, 13.56 MHz
Openpath Bluetooth	Yes
NFC	Yes
Wave to Unlock/Touch	Yes
Auto Proximity Unlock	Yes
Openpath Prox Cards/Fobs	Yes
HID® Prox	Yes
LenelProx®	Yes
Openpath DESFire EV3	Yes
MIFARE/DESFire (CSN)	Yes
Standards	ISO 14443A, Prox
Environmental	Indoor use only

### Features

- Snap-off brackets support multiple mounting applications
- USB port supports enrollment reader and secured printing functionality
- Small size fits inside turnstiles, elevators, kiosks, and other embedded applications
- Supports auxiliary Wiegand readers connected through the Openpath reader
- Functions seamlessly with the mobile application
- Available on both Android and iOS
- Works with Smart Watches in addition to the mobile app
- Supports remote unlocking with user-level privileges
- Lifetime warranty

### Installation

- Easy installation via RS-485 wiring or USB connection
- Compatible with legacy Wiegand wiring

PIN	Name (short)	Name (full)
1	LED	Wiegand LED
2	BUZZER	Wiegand Buzzer
3	WD1	Wiegand Data 1
4	WD0	Wiegand Data 0
5	-A	RS485-A
6	+B	RS485-B
7	VO	Wiegand Voltage
8	GND	Wiegand RTN
9	VIN	+12V IN
10	GND	Ground (RTN)

RS-485 and  
Wiegand Terminal  
Block Definitions

Temperature should not exceed -30°C to 60°C (-22°F to 140°F)

### Security

- Fully encrypted communication between mobile app and controller
- Fully encrypted communication between Openpath key cards and reader
- Eliminates the threat of copying or cloning Openpath key cards
- Includes tamper resistant secure storage

### System Compatibility

- Reader works with Openpath Access System including Openpath controllers, cloud management software, and mobile app
- Reader works with legacy access control systems via Mobile Gateway option

### Dimensions

- With all tabs intact: 4.6 x 10.2 x 1.8 cm (1.8 x 4 x 0.7 in)
- With outer tabs removed: 4.6 x 8.9 x 1.8 cm (1.8 x 3.5 x 0.7 in)
- With all tabs removed: 4.6 x 7 x 1.8 cm (1.8 x 2.8 x 0.7 in)

### Power Rating

- 0.5A @ 5VDC
- 0.25A @ 12VDC
- 0.12A @ 24VDC

