

Technical Support

📞 01273 811011

✉️ support@paxton.co.uk

Technical help is available: Monday - Friday from 07:00 - 19:00 (GMT)
Saturday from 09:00 - 13:00 (GMT)

Documentation on all Paxton products can be found on our website - <http://www.paxton.co.uk/>

Layout

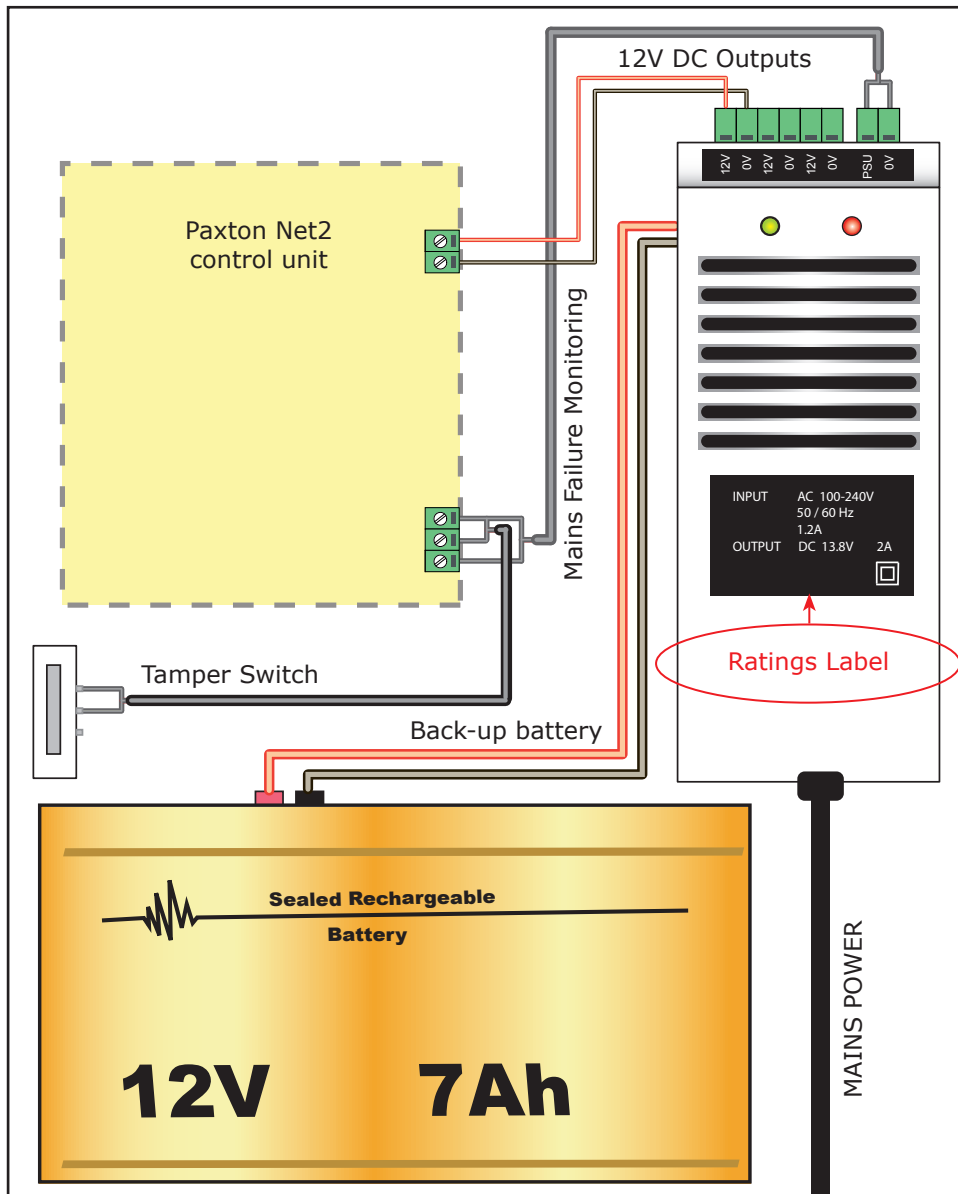

The Tamper switch type and position will vary due to the different case styles.

IMPORTANT: The equipment connected to this power supply must not exceed its 2A rating.

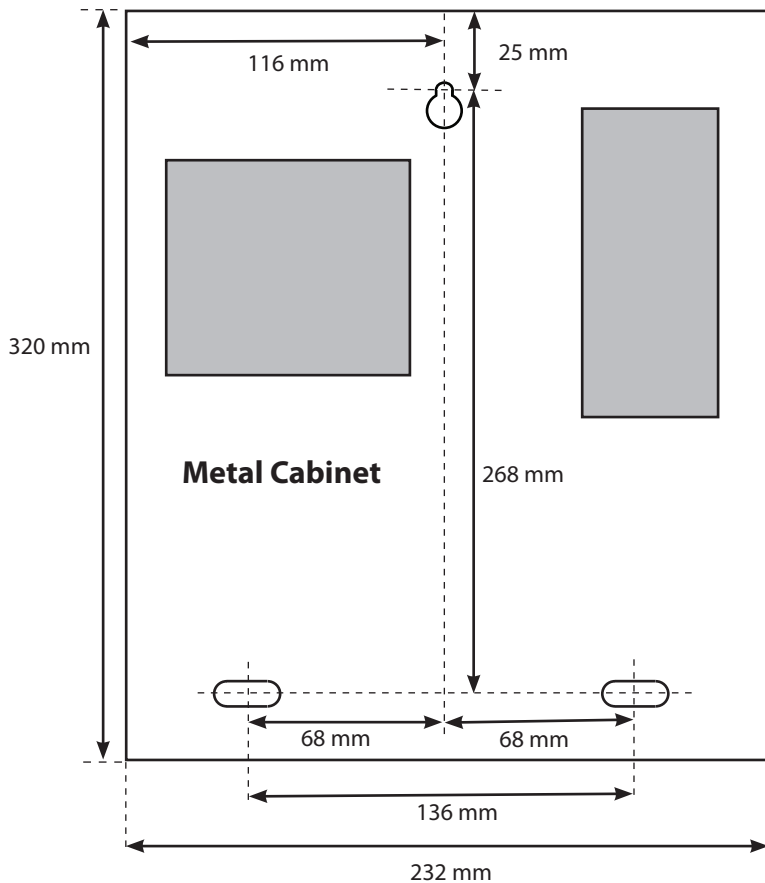

Fitting

1. Screws and wall plugs are provided in a fitting kit. With reference to the diagrams, determine where the top, central mounting position is required and drill a hole suitable for a No 8 wall plug.
2. Tap in one of the wall plugs.
3. Put in one of the long screws, leaving a suitable gap to the wall surface and slide the cabinet over it.
4. Mark the hole positions for the lower 2 screws.
5. Remove the cabinet and drill the additional holes.
6. Tap in the 2 wall plugs and hang the cabinet back onto the top screw.
7. Secure the cabinet with the 2 lower screws.
8. Tighten the top screw.

AC Mains Connection

A detachable figure 8 power cable is provided with the unit. This is pre-stripped at one end for connection to a fused spur.

Anchor points are supplied inside the case to secure the incoming mains cable. (cable tidy/ties are provided) There are also 'knock-outs' in the case to allow convenient access for the cable.

Ensure that the supplied compression gland is used when passing the mains cable through any holes in the cabinet.

The power supply is double insulated and requires no additional earth connection.

The PSU's battery function will not work until this unit has first been connected to the mains supply. It is the loss of this supply that switches the unit to battery power.

This product is not suitable for retail sale. All warranties are invalid if this product is not installed by a competent person.

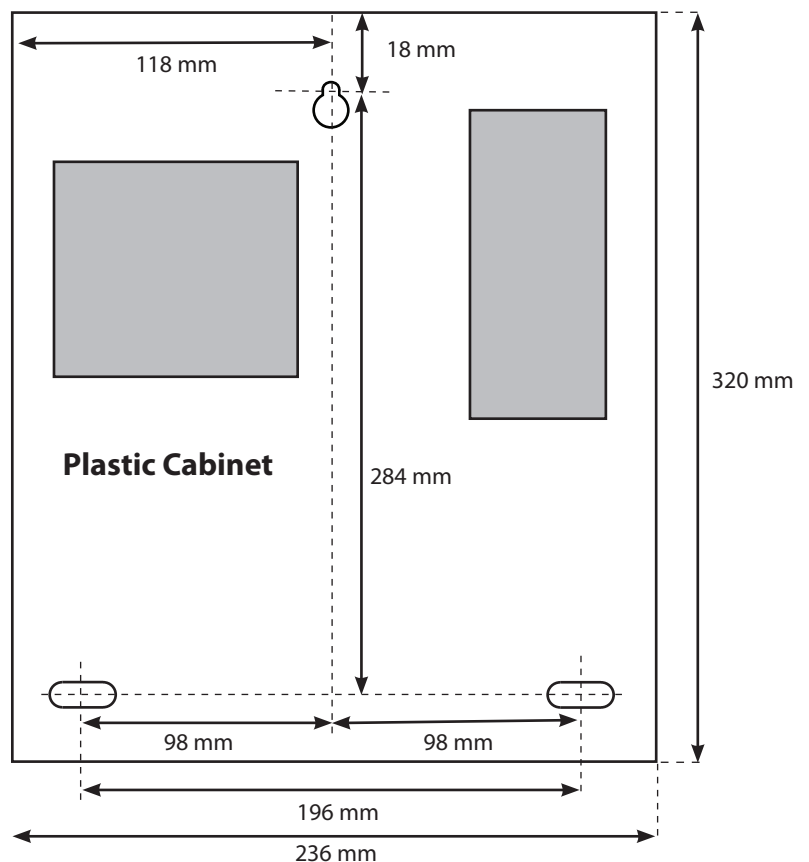

A Net2 nano ACU or a Hands free interface cannot be installed in the Metal cabinet as this would block the RF signal used for the Net2Air wireless technology.

Status Lights

Green	This LED is on when the input supply is healthy.
Red	This LED is on when the input supply has failed - Power is being supplied by the battery.

Features

Battery backup	The cabinet can accommodate a 12V / 7Ah battery.
Fast/Trickle charge	The battery is continuously charged to keep it at maximum capacity.
Deep discharge protection	If battery voltage falls below 9.5V, it will automatically disconnect - Red LED goes out.
Mains failure alarm (PSU)	Registers an alarm if the mains power fails when connected to an ACU or I/O board.
Tamper alarm	Registers an alarm if the lid is opened when connected to an ACU or I/O board.

Statement of Conformity



The declaration of conformity is available on request. Contact details are provided at: <http://paxton.info/596>

Specifications

PSU Electrical	Min	Max	
Output voltage	13V DC	13.8V DC	
Maximum load output current		2 A	
Maximum battery charging current		1 A	
Mains supply voltage	100V AC	240V AC	+/- 10%
Mains supply current		1.2 A	
Mains supply frequency	50 Hz	60 Hz	+/- 3 Hz
ACU Electrical			
See accompanying documentation (ins-30000 - Net2 classic, ins-30075 - Net2 nano, ins-30080 - Net2 plus)			
Environment	Min	Max	
Operating temperature - Battery limits	0 °C	+45 °C	
Waterproof			No
Dimensions	Width	Height	Depth
Metal Cabinet	232mm	320mm	80mm
Plastic Cabinet	236mm	320mm	80mm
Battery Compartment (Plastic Housing)	150mm	100mm	62mm

WARNINGS

The following warnings and instructions MUST be adhered to. Read the instructions before installing and powering the equipment. Keep the instructions in a safe place for future reference.

RECEIVING INSPECTION- Remove any traces of packing material from the unit as such debris may create a fire or shock hazard. Unpack the unit with care and inspect for transit damage. If damage is suspected, the unit must not be used or tested, but should be returned to Paxton for investigation and the damage reported to the carrier.

INSTALLATION- Only qualified and trained personnel, familiar with this type of product and who fully understand these instructions should install, connect or test this equipment. There are no user serviceable parts within the PSU unit.

- The equipment is intended for indoor use only in dry locations. This is a Class A product. In a domestic environment this product may cause radio interference in which case the user may be required to take adequate measures.

- The installation must meet National Wiring Regulations and IEC60950-1 standards.

- Disconnect Devices: A readily accessible disconnect device shall be incorporated in the building wiring to include an appropriately rated circuit breaker to disconnect both poles with at least a 3.0 mm contact gap. After switch off, all internal capacitors will discharge to safe levels within 60 seconds under normal conditions. Under fault conditions, charge may be held for much longer and suitable precautions should be taken before handling the unit.

- Protection device: The fusing characteristics of the protection device to be used are T3.15AH250V

SAFETY WARNING

RISK OF EXPLOSION IF BATTERY IS REPLACED BY AN INCORRECT TYPE.

DISPOSE OF USED BATTERIES ACCORDING TO THE INSTRUCTIONS.