

Spectra[®] Professional IR and 4K Series IP PTZ Outdoor Camera Operations Manual



P2230-ESR

P2820-ESR

P2230L-ESR

Contents

- Important Safety Instructions.....4
- Important Notices5
 - Regulatory Notices [FCC CLASS A]5
 - Legal Notice [Audio Notice].....5
 - Video Quality Caution5
 - Open Source Software.....6
 - Korean Class A EMC6
 - ESD Warning6
 - Warranty6
 - Network Topology Statement.....6
- Preface.....7
- 1. Product Overview**.....8
 - 1.2 Physical Characteristics8
- 2. Installation and Connection**10
 - 2.1 Unpacking Everything10
 - 2.2 Optional Accessories10
 - 2.3 Installation.....10
 - 2.3.1 Checking Appearance10
 - 2.3.2 Inserting the Micro SD Card10
 - 2.3.3 Installing the Camera.....11
 - 2.3.4 Connecting the Wires13
 - 2.3.5 Completing the Installation14
 - 2.3.6 Adjusting the Field of View15
 - 2.3.7 Network Topology.....15
 - 2.3.8 System Requirements16
 - 2.4 Connection.....17
 - 2.4.1 Default IP address17
 - 2.4.2 Connecting from a Computer & Viewing Preparation17
- 3. Administration and Configuration**.....19

3.1 Live	19
3.2 Settings	22
3.2.1 System.....	22
3.2.2 Network & Security	27
3.2.3 Imaging.....	40
3.2.4 PTZ.....	46
3.2.5 A/V Streams.....	56
3.2.6 Events.....	64
Pelco Troubleshooting Contact Information	74

Important Safety Instructions

1. Read these instructions.
2. Keep these instructions.
3. Heed all warnings.
4. Follow all instructions.
5. Clean only with dry cloth.
6. Do not install near any heat sources such as radiators, heat registers, stoves, or other apparatus (including amplifiers) that produce heat.
7. Only use attachments/accessories specified by the manufacturer.
8. Refer all servicing to qualified service personnel. Servicing is required when the apparatus has been damaged in any way, such as power-supply cord or plug is damaged, liquid has been spilled or objects have fallen into the apparatus, does not operate normally, or has been dropped.
9. Installation should be done only by qualified personnel and conform to all local codes.
10. Use only installation methods and materials capable of supporting four times the maximum specified load.
11. Use stainless steel hardware to fasten the mount to outdoor surfaces.
12. To prevent damage from water leakage when installing a mount outdoors on a roof or wall, apply sealant around the bolt holes between the mount and mounting surface.
13. The mounting height above ground level shall be more than 3 meter for wall mount height.

CAUTION: These servicing instructions are for use by qualified service personnel only. To reduce the risk of electric shock do not perform any servicing other that contained in the operating instructions unless you are qualified to do so.

Only use replacement parts recommended by Pelco.

The product and/or manual may bear the following marks:



This symbol indicates that dangerous voltage constituting a risk of electric shock is present within this unit.

CAUTION: RISK OF ELECTRIC SHOCK. DO NOT OPEN.



This symbol indicates that there are important operating and maintenance instructions in the literature accompanying this unit



WARNING: HAZARDOUS MOVING PARTS. KEEP FINGERS AND OTHER BODY PARTS AWAY.



Denotes Class II double insulated device.



WARNING: This product is sensitive to Electrostatic Discharge (ESD). To avoid ESD damage to this product, use ESD safe practices during installation. Before touching, adjusting or handling this product, correctly attach an ESD wrist strap to your wrist and appropriately discharge your body and tools. For more information about ESD control and safe handling practices of electronics, please refer to ANSI/ESD S20.20-1999 or contact the Electrostatic Discharge Association (www.esda.org).

Important Notices

Regulatory Notices [FCC CLASS A]

This device complies with Part 15 of the FCC Rules. Operation is subject to the following two conditions: (1) this device may not cause harmful interference, and (2) this device must accept any interference received, including interference that may cause undesired operation.

Radio and Television Interference

This equipment has been tested and found to comply with the limits of a Class A digital device, pursuant to Part 15 of the FCC rules. These limits are designed to provide reasonable protection against harmful interference when the equipment is operated in a commercial environment. This equipment generates, uses, and can radiate radio frequency energy and, if not installed and used in accordance with the instruction manual, may cause harmful interference to radio communications. Operation of this equipment in a residential area is likely to cause harmful interference in which case the user will be required to correct the interference at his own expense.

Changes and Modifications not expressly approved by the manufacturer or registrant of this equipment can void your authority to operate this equipment under Federal Communications Commission's rules.

This Class A digital apparatus complies with Canadian ICES-003.

Cet appareil numérique de la classe A est conforme à la norme NMB-003 du Canada.

Legal Notice [Audio Notice]

SOME PELCO EQUIPMENT CONTAINS, AND THE SOFTWARE ENABLES, AUDIO/VISUAL AND RECORDING CAPABILITIES, THE IMPROPER USE OF WHICH MAY SUBJECT YOU TO CIVIL AND CRIMINAL PENALTIES. APPLICABLE LAWS REGARDING THE USE OF SUCH CAPABILITIES VARY BETWEEN JURISDICTIONS AND MAY REQUIRE, AMONG OTHER THINGS, EXPRESS WRITTEN CONSENT FROM RECORDED SUBJECTS. YOU ARE SOLELY RESPONSIBLE FOR INSURING STRICT COMPLIANCE WITH SUCH LAWS AND FOR STRICT ADHERENCE TO ANY/ALL RIGHTS OF PRIVACY AND PERSONALTY. USE OF THIS EQUIPMENT AND/OR SOFTWARE FOR ILLEGAL SURVEILLANCE OR MONITORING SHALL BE DEEMED UNAUTHORIZED USE IN VIOLATION OF THE END USER SOFTWARE AGREEMENT AND RESULT IN THE IMMEDIATE TERMINATION OF YOUR LICENSE RIGHTS THEREUNDER.

NOTE: Improper use of audio/visual recording equipment may subject you to civil and criminal penalties. Applicable laws regarding the use of such capabilities vary between jurisdictions and may require, among other things, express written consent from the recorded subjects. You are solely responsible for insuring strict compliance with such laws and for strict adherence to any/all right of privacy and personality.

Video Quality Caution

Frame Rate Notice Regarding User Selected Options

Pelco systems are capable of providing high quality video for both live viewing and playback. However, the systems can be used in lower quality modes, which can degrade picture quality, to allow for a slower rate of data transfer and to reduce the amount of video data stored. The picture quality can be degraded by either lowering the resolution, reducing the picture rate, or both. A picture degraded by having a reduced resolution may result in an image that is less clear or even indiscernible. A picture degraded by reducing the picture rate has fewer frames per second, which can result in images that appear to jump or move more quickly than normal during playback. Lower frame rates may result in a key event not being recorded by the system.

Judgment as to the suitability of the products for users' purposes is solely the users' responsibility. Users shall determine the suitability of the products for their own intended application, picture rate and picture quality. In the event users intend to use the video for evidentiary purposes in a judicial proceeding or otherwise, users should consult with their attorney regarding any particular requirements for such use.

Open Source Software

This product includes certain open source or other software originated from third parties that is subject to the GNU General Public License (GPL), GNU Library/Lesser General Public License (LGPL) and different and/or additional copyright licenses, disclaimers, and notices.

The exact terms of GPL, LGPL, and some other licenses are provided to you with this product. Please refer to the exact terms of the GPL and LGPL at <http://www.fsf.org> (Free Software Foundation) or <http://www.opensource.org> (Open Source Initiative) regarding your rights under said license. You may obtain a complete corresponding machine-readable copy of the source code of such software under the GPL or LGPL by sending your request to digitalsupport@pelco.com; the subject line should read Source Code Request. You will then receive an email with a link for you to download the source code.

This offer is valid for a period of three (3) years from the date of the distribution of this product by Pelco.

Korean Class A EMC

이 기기는 업무용 (A 급) 전자파 적합기기로서 판매자 또는 사용자는 이 점을 주의하시길 바라며, 가정 외의 지역에서 사용하는 것을 목적으로 합니다.

ESD Warning



WARNING: This product is sensitive to Electrostatic Discharge (ESD). To avoid ESD damage to this product, use ESD safe practices during installation. Before touching, adjusting or handling this product, correctly attach an ESD wrist strap to your wrist and appropriately discharge your body and tools. For more information about ESD control and safe handling practices of electronics, please refer to ANSI/ESD S20.20-1999 or contact the Electrostatic Discharge Association (www.esda.org).

Warranty

For information about Pelco's product warranty and thereto related information, refer to www.pelco.com/warranty.

Network Topology Statement

IMPORTANT NOTE. PLEASE READ. The network implementation is shown as a general representation only and is not intended to show a detailed network topology. Your actual network will differ, requiring changes or perhaps additional network equipment to accommodate the system as illustrated. Please contact your local Pelco representative to discuss your specific requirements.

Preface

This user manual is to be used as a reference for the installation and manipulation of the camera unit including features, functions, and a detailed explanation of the menu tree.

This manual provides the following information:

- **Product Overview:** The main functions and system requirements of the unit.
- **Installation and Connection:** Instructions on unit installation and wire connections.
- **Administration and Configuration:** The main menu navigation and controls explanations.

1. Product Overview

1.2 Physical Characteristics

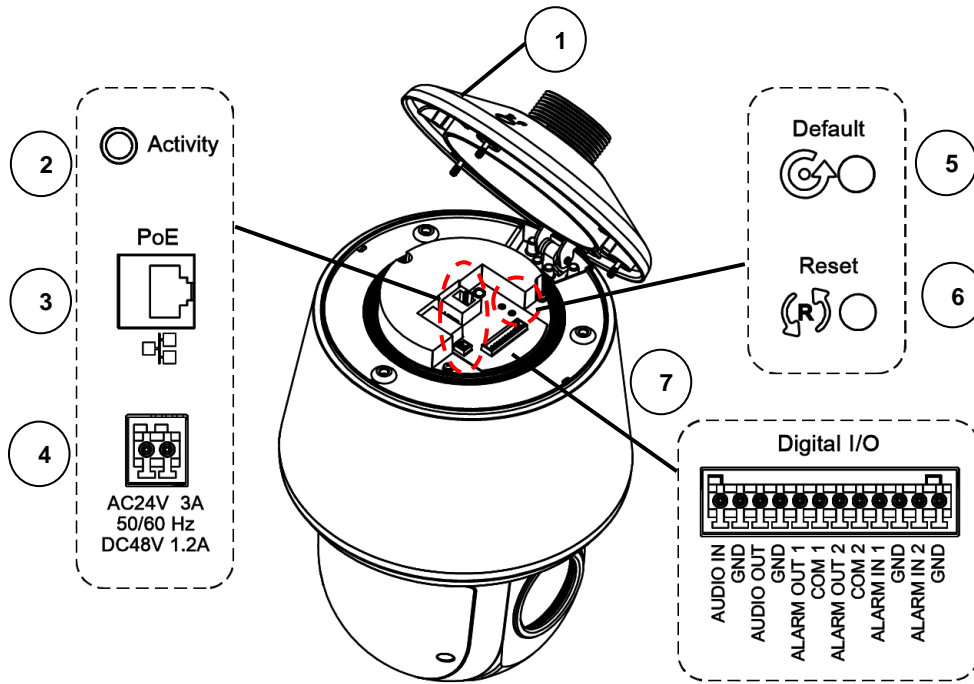

FIGURE 1-1: CAMERA CONNECTIONS AND FEATURES 1/2

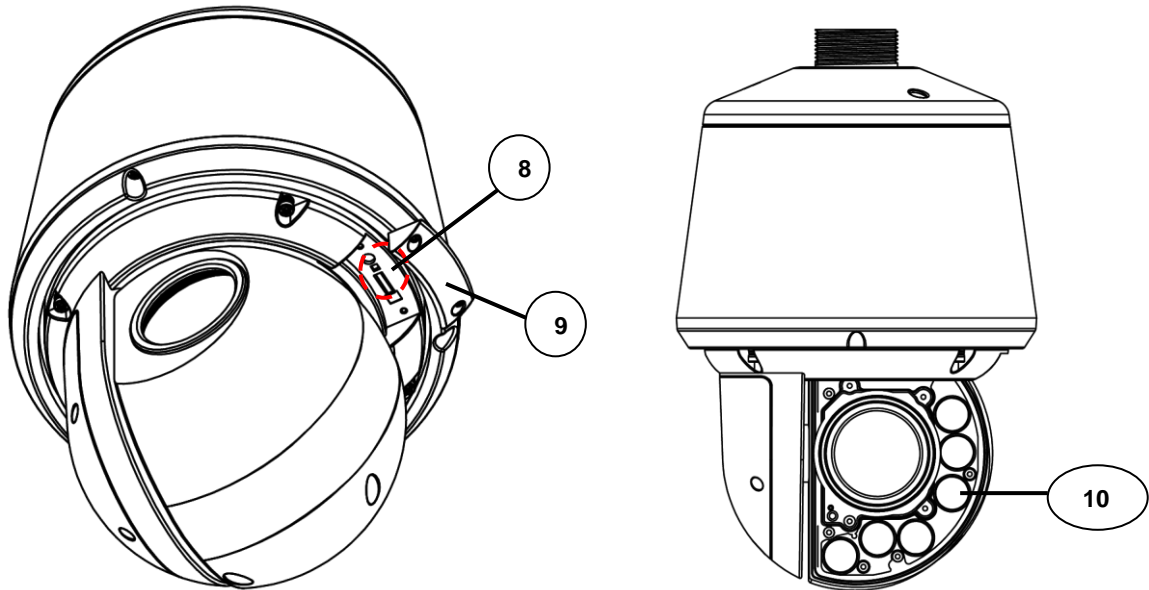

FIGURE 1-2: CAMERA CONNECTIONS AND FEATURES 2/2

1. **Pendant Cap:** Open the pendant cap by loosening the T-20 torx star screws and then connect required items (digital I/O connectors, power terminal, and RJ-45 network port) if necessary. In addition, both the reset and default buttons are embedded here for utilization when needed.
2. **Activity Behaviors:**
 - **Booting:** With a fast flashing green, the LED indicates the camera is currently booting.

- **Software updating:** With alternating fast/slow flashing green, the LED indicates the camera is updating software.
 - **Booting failure:** With a slower flashing green, the LED indicates the camera failed to boot.
 - **Booting completion:** With the green light off, the LED indicates the camera has completed booting.
3. **RJ-45 Network Port:** Connect the RJ-45 plug to this port for network connection. The Network Port accepts a PoE BT (Class 7) power sourcing equipment (PSE) to supply power through Ethernet cable.
 4. **Power Terminal:** The port is to connect with either external DC 48V or AC 24V power supply. **NOTE: There is no polarity for the power connection.**
 5. **Default Button:** Press the button for 5 seconds to restore the camera's settings back to the factory default.
 6. **Reset Button:** Press the button for approximately 1 second to reboot the camera.
 7. **Digital I/O Connectors:**
 - **Alarm In:** Via "GND" and "AI" ports, connect to external device that can trigger alarm input signals.
 - **Alarm Out:** Via "COM" and "AO" ports, connect to external device to be triggered through alarm output signals.
 - **Audio In:** Via "Au/I" and "GND" ports, connect to external device such as microphone that receives sound for camera.
 - **Audio Out:** Via "Au/O" and "GND" ports, connect to device such as speaker to be triggered through alarm output signals.
 8. **Micro SD Card Slot:** This slot is for inserting an optional micro SD card (not supplied) for local file storage.
 9. **SD Card Cover:** Open the SD card cover by loosening the T-6 torx star screws and then insert micro SD card, if necessary.
 10. **IR Board:** The IR LED embedded board for illumination under a low-light environment. (The IR Board is hidden under the front window assembly).

Note

1. The product is intended to be supplied by a Listed Power Unit marked "L.P.S." (or "Limited Power Source") and rated output 24Vac, 50/60Hz, 3A, 48Vdc, 1.2A or PoE BT, 0.96A minimum.
 2. The product shall be installed by a qualified service person and the installation shall conform to all local codes.
-

2. Installation and Connection

2.1 Unpacking Everything

Check all items in the product box against the order form and the packing slip. In addition to this manual, the items below are included in the product box.

- IP PTZ Outdoor Dome * 1
- Pin-in T-20 Torx Star Wrench * 1
- Pin-in T-6 Torx Star Wrench * 1
- 12-pin Terminal Block * 1
- 2-pin Terminal Block *1
- Printed Installation Manual, Important Safety Instructions, and Resources Sheet * 1
- Rubber Cap * 3
- Anti-Seize Lubricant (Dow Corning MOLYKOTE 4 Electrical Insulating Compound)*1
- Printed ROHS Statement Slip *1
- Water Proof Gland

Please contact your dealer if any item is missing.

2.2 Optional Accessories

The following tools and parts might help you complete the installation:

- Drill
- Screwdriver
- Wire Cutter
- IWM/IDM/SWM or PP series mounts offered by Pelco (not supplied), (refer to specification sheet for application mounts)
- Pipe Nipple Adapters (if using pipe/conduit)
- Conduit Adapters (if applicable)
- Rain Tight Compression Connector with Lock Nut (if applicable)
- RJ-45 Connector to Terminate Wires
- Cat5 (or higher) Cable
- 2-Wire Power Cable and 12-Wire Multi-Conductor Cable (if using alarms, relays and/or line-in and line-out audio) is limited to 28-20AWG range.

2.3 Installation

2.3.1 Checking Appearance

Although the protective materials used for the packaging should be able to protect the unit from most accidents during transportation, check the unit and its accessories for any visible damage. Remove the protective film to check items in accordance with the list in **2.1 Unpacking Everything**

2.3.2 Inserting the Micro SD Card

1. If necessary, loosen the 2 (T-6) SD card cover screws with a T-6 torx star wrench (supplied).
2. Remove the SD card cover to insert a micro SD card (not supplied) into the slot.
3. After that, use the T-6 torx star wrench to tighten the 2 (T-6) SD card cover screws and complete insertion.

NOTE: The recommended torque of the screw is 0.3 Nm (Newton meter).

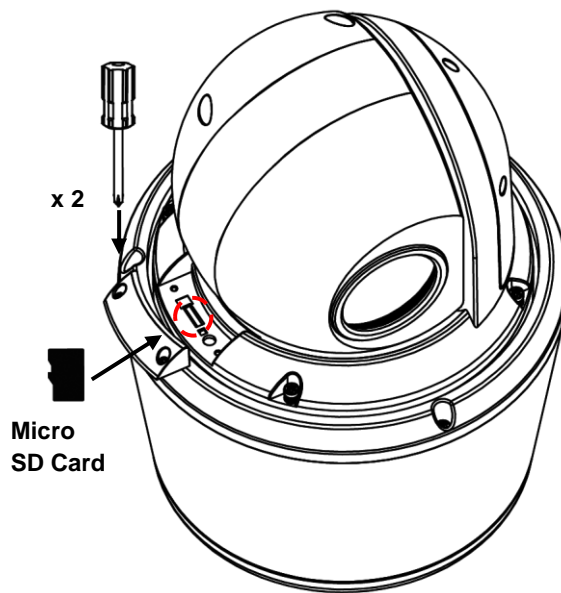

FIGURE 2 - 1: INSERTING MICRO SD CARD

2.3.3 Installing the Camera

You can install the Spectra[®] Professional IR and 4K Series IP PTZ Outdoor Camera by using the following method.

- **Installation using pipe/conduit (not supplied) or a Pelco mount such as IWM/IDM/SWM or PP series (refer to 2.3.3.1 Installation with Pelco Mount) (not supplied)**

2.3.3.1 Installation with Pelco Mounts

1. Install a Pelco mount such as IWM/IDM/SWM or PP series (not supplied) on the walls or the ceiling. Refer to the instructions supplied with the mount.
2. Before mounting the camera, make sure that the network cable, power cable and digital I/O cables have been passed through a Pelco mount (IWM) series (not supplied).
3. If using the supplied water proof gland (recommended), puncture a round hole(s) in the gland that is smaller than the diameter of the cable that will be passed through the gland. Feed an unterminated cable thru the hole in the gland. Terminate the cable with the appropriate connector.
4. Apply anti-seize lubricant (supplied) to the camera's pendant cap threads before attaching the camera to the mount. After that, mount the camera on a Pelco mount (IWM) series (not supplied).

NOTE:

- a. **Mounts must be sealed to prevent condensation in the camera.**
- b. **Please install the camera carefully to avoid dropping the camera and injuring the installer.**
- c. **Do not fully tighten the camera to the mount. Thread the camera onto the mount ensuring the T-20 screws on the top of the camera are accessible.**

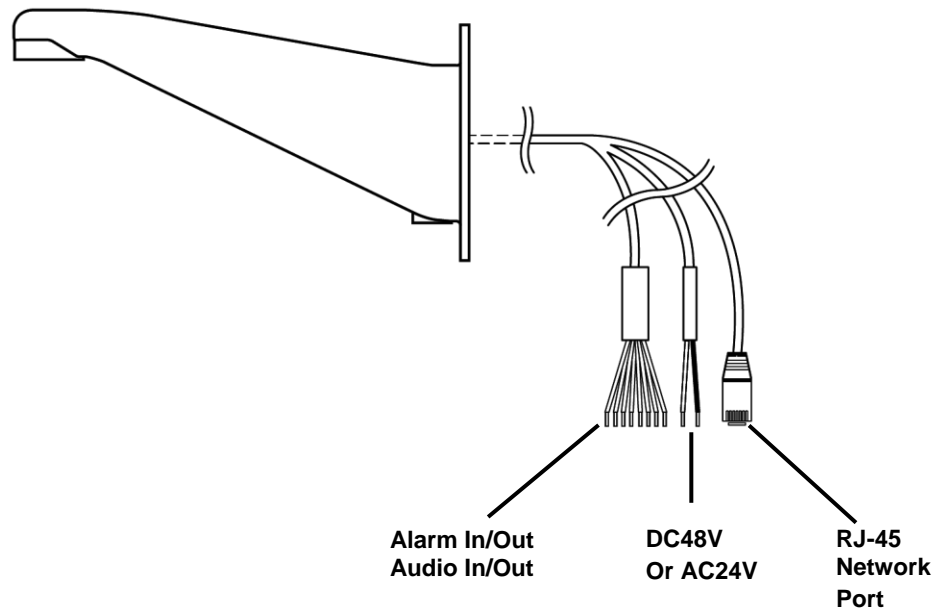

FIGURE 2-2: ROUTING THE CABLES

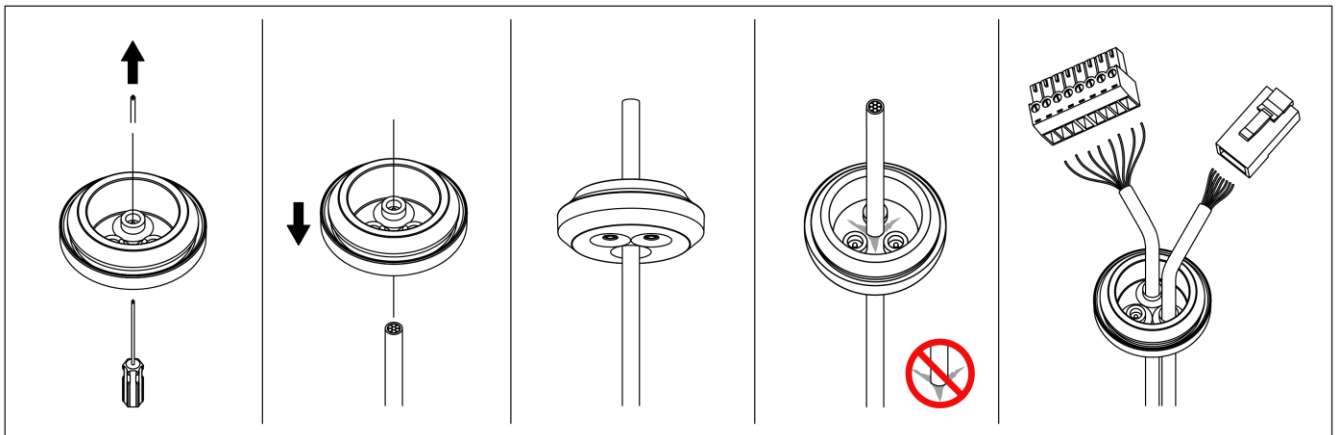

FIGURE 2-3: USING WATER PROOF GLAND

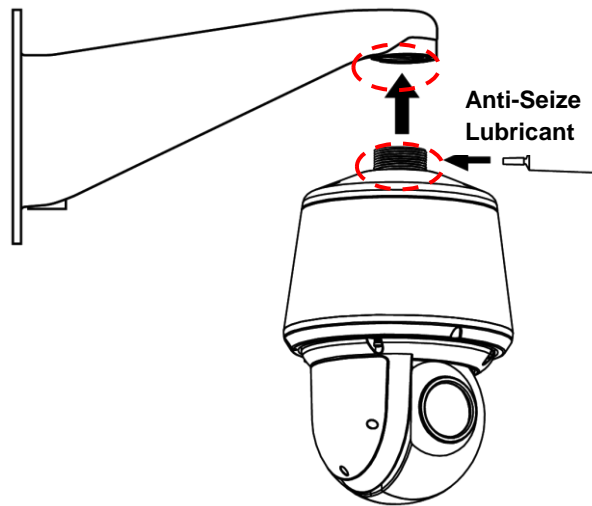

FIGURE 2-4: MOUNTING THE CAMERA

2.3.4 Connecting the Wires

- Loosen the 3 (T-20) pendant cap screws with a T-20 torx star wrench (supplied), and let the camera's body shift downward.

NOTE:

- Be careful when letting the camera's body shift downward to avoid it hitting someone or something.
- The recommended method of locking and unlocking 3 screws is as follows. Please follow these introductions. Also, the recommended torque of the screw is 2.0 ± 0.2 Nm (Newton meter).

- Unlocked:** To loosen the pendant cap screws in the counterclockwise direction (Steps 1-2-3).
- Locked:** To tighten the pendant cap screws in the clockwise direction (Steps 1-2-3)

- Based on your needs, connect the power cable to the power port via one of the following 3 options.
 - AC 24V: Connect a power cable that supplies AC24V power source to the power terminal.
 - DC 48V: Connect a power cable that supplies DC48V power source to the power terminal.
 - PoE BT (Class 7): Connect an Ethernet cable terminated with RJ-45 p to the PoE BT RJ-45 port for both power supply and network connectivity purposes simultaneously.

NOTE:

- The recommended wire size that can be used with 2-pin Power connector is limited to 28-20 AWG range
- As soon as the camera is powered it will start to rotate and configure pan/tilt/zoom.

- Also, connect the digital I/O (alarm in/out & audio in/out) cables to the connectors of unit if required.

NOTE:

- The recommended wire size that can be used with 12-pin Audio/Alarm connectors is limited to 28-20 AWG range.
- It is recommended to use the Cable Grommet (supplied) to ensure the product is sealed. After feeding the cables through the grommet, insert the grommet into the hole located at the top of the rear cap. Alternatively, a cable sealing gland (not supplied) can be used.

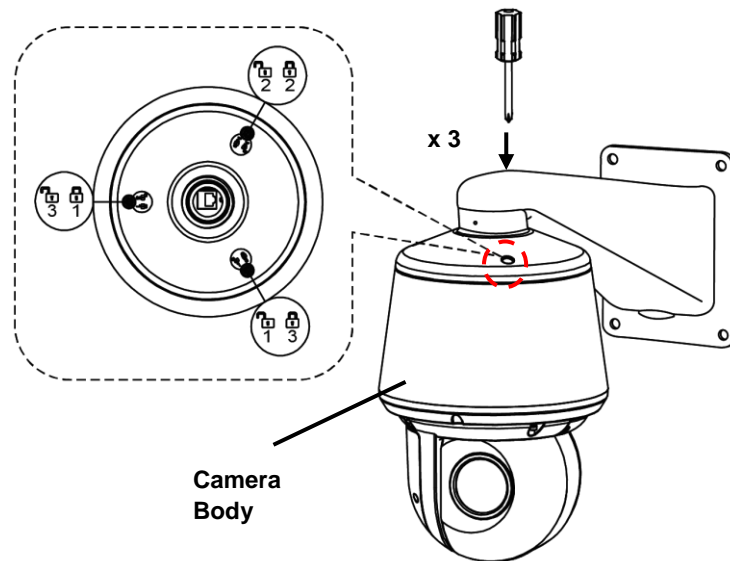

FIGURE 2-5: LOOSENING THE PENDANT CAP

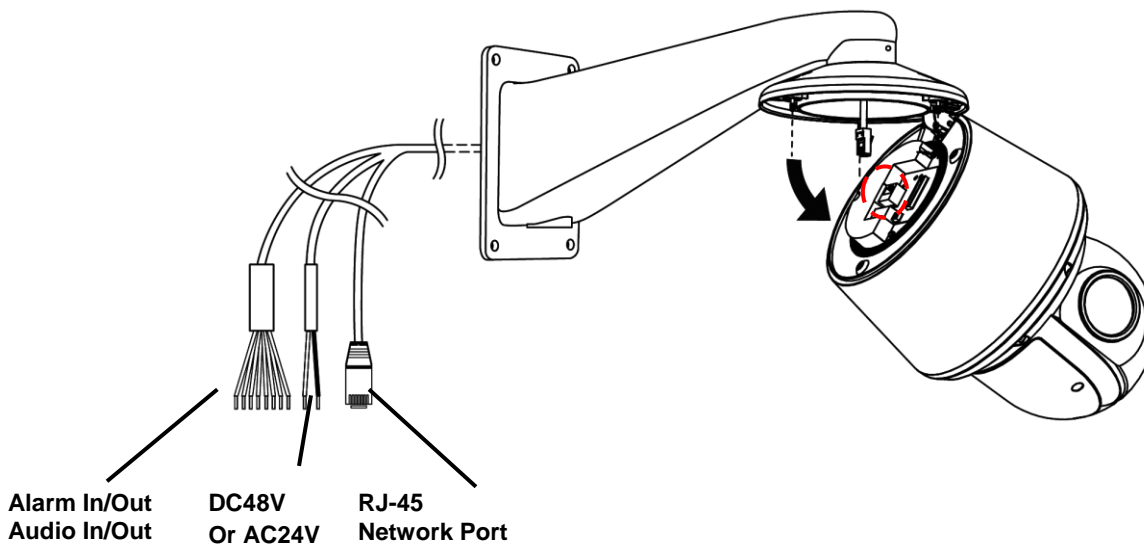

FIGURE 2-6: CONNECTING THE WIRES

2.3.5 Completing the Installation

1. Close the pendant cap by letting the camera's body shift upward. After that, use the T-20 torx star wrench (supplied) to tighten the 3 (T-20) pendant cap screws. **NOTE: Please pay attention to the locking direction. Also, the recommended torque of the screw is 2.0 ± 0.2 Nm (Newton meter).**
2. Fully tighten the camera to the mount by threading the camera 1 turn past hand tight.
3. Cover the 3 (T-20) pendant cap screws with the 3 rubber caps to complete the installation.

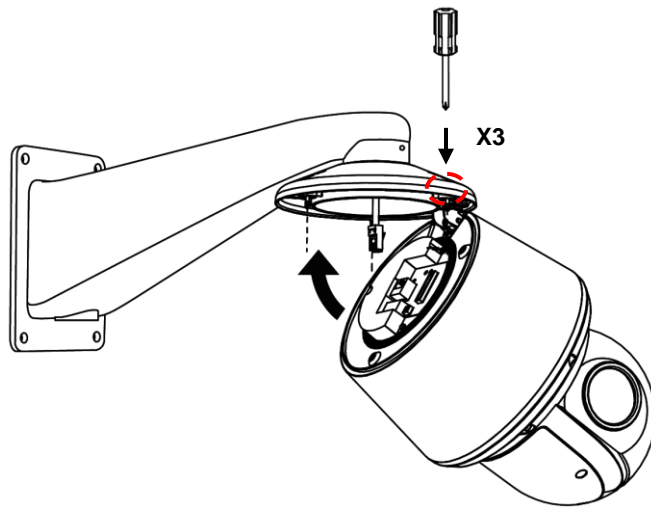

FIGURE 2-7: TIGHTENING THE PENDANT CAP

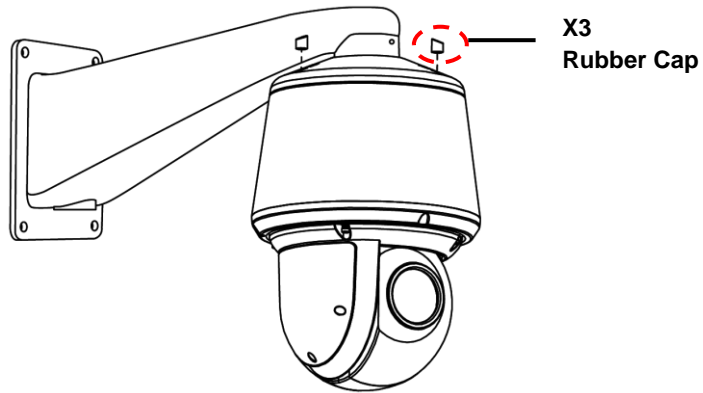

FIGURE 2-8: COVERING THE RUBBERS

2.3.6 Adjusting the Field of View

1. View the camera image using the browser (refer to **2.4 Connection** on **page 17**).
2. Utilize the settings in the Web interface (refer to **3.1 Live on page 21**) to move the lens to the desired field of view.
3. Use the settings in the Web interface (refer to **3.1 Live on page 21**) to adjust the zoom and focus of the lens to the desired field of view

NOTE: Focus adjustment and PTZ functions are done exclusively by Web UI.

2.3.7 Network Topology

The unit, which is equipped with Ethernet RJ-45 network interface, can deliver video images in real time via either Internet or Intranet. Please refer to the skeleton drawings shown below to aid your understanding.

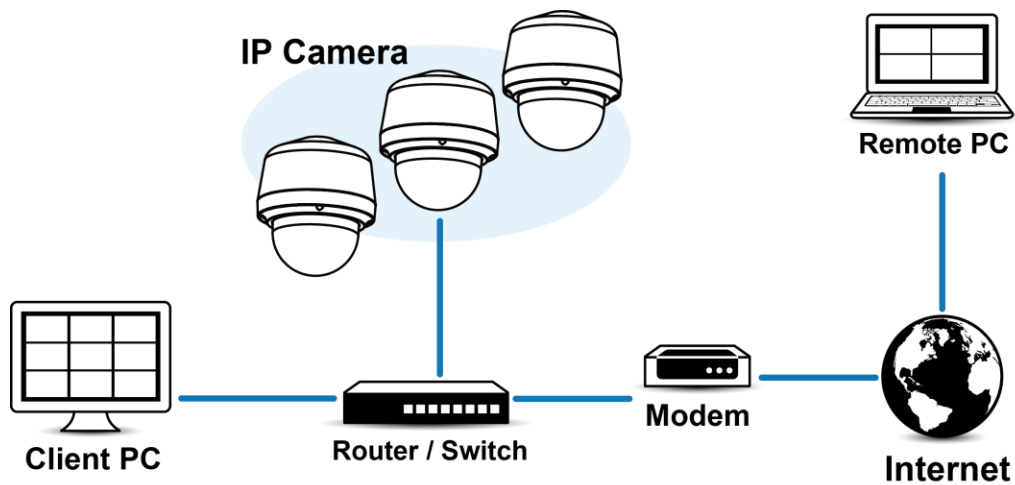

FIGURE 2-9: NETWORK TOPOLOGY

2.3.8 System Requirements

The table below lists the minimum requirements to implement and operate a unit. Network and processor bandwidth limitations might cause the video stream to pause or appear pixelated when additional Web-interface users connect to the camera. Decrease the images per second (ips), resolution, compression, or bit rate settings of the Web interface video streams to compensate for network/processor limitations.

TABLE 2-1: SYSTEM REQUIREMENTS

System Hardware	
CPU	Intel® Pentium® 4 microprocessor, 2.4GHz or equivalent
RAM	1 GB or above
Monitor	Minimum of 1024 x 768 resolution, 16- or 32-bit pixel color resolution
System Software	
Operating System	Microsoft Windows 10, Microsoft Windows XP, Win7 32 and 64 bit
Browser	Microsoft IE 10 and later, Chrome, Firefox
Media Player	Pelco Media Player or QuickTime® 7.6.5 for Windows XP and Windows 7; or QuickTime 7.6.4 for Mac OS X 10.4 (or later)
Unit	
Power Supply	PoE BT / AC 24V /DC 48V

1. All the installation and operations should comply with your local electricity safety rules.
2. This product is not compatible with QuickTime version 7.6.4 for Windows XP. If you have this version installed on your PC, you will need to upgrade to QuickTime version 7.6.5.
3. Network and processor bandwidth limitations might cause the video stream to pause or appear pixelated when additional Web-interface users connect to the camera. Decrease the images per second (ips), resolution, compression, or bit rate settings of the Web interface video streams to compensate for network or processor limitations.

Note

2.4 Connection

2.4.1 Default IP address

The unit's default IP address is **192.168.0.20** and sub mask is **255.255.255.0**. When setting default IP address of 192.168.0.20 the camera will check to see if that address is already in use and will bump the last octet of the address by 1 if it is. The bump last octet of IP Address by 1 will continue until an unused IP address is found.

However, if you have a DHCP server in your network, the unit would obtain an IP address automatically from the DHCP server so that you don't need to change the camera's IP address. The factory default is DHCP **On** and 192.168.0.20 assignment only occurs when camera is set for DHCP but a DHCP server does not respond to request for an IP address.

2.4.2 Connecting from a Computer & Viewing Preparation

2.4.2.1 Using Pelco Device Utility Software to Get Camera's IP Address

Pelco Device Utility software is a utility program that helps users to manage and configure the camera. Use the utility to find the IP address since the default option is to obtain an IP address via DHCP and therefore the IP address will NOT be known. Steps to get the utility program running are listed below.

1. Finish installing the Device Utility to the computer according to the installation instructions.
2. Log in to the Device Utility by entering the camera's User name and Password. In the window, enter the previously created user name and password, then click **Enter** button to log in.
3. In the Manage Devices page, you can click Refresh Device List or Add New Device to search for the devices.
4. From the Device List, you can get series information about the camera, IP Address included.

For more information about using the Device Utility, click this green icon  on the upper-right corner of the Device Utility page.

2.4.2.2 Connecting from a computer

1. Check if there is networking available between the unit and the computer by executing ping the default IP address. Start a command prompt (Windows: from the Start Menu, select Program. Select Accessories and choose Command Prompt.), and type "Ping 192.168.0.20". If the message "Reply from..." appears, it means the connection is available.
2. Start Internet Explorer and enter IP address: **192.168.0.20**. A login window should pop up. In the window, enter the created friendly user name and created password to log in.

NOTE: If you do not know the camera's IP address, you can locate it using the Pelco Device Utility software (refer to **2.4.2.1 Using Pelco Device Utility Software to Get Camera's IP Address**).

Further administration on the unit can be found in "[3. Administration and Configuration](#)".

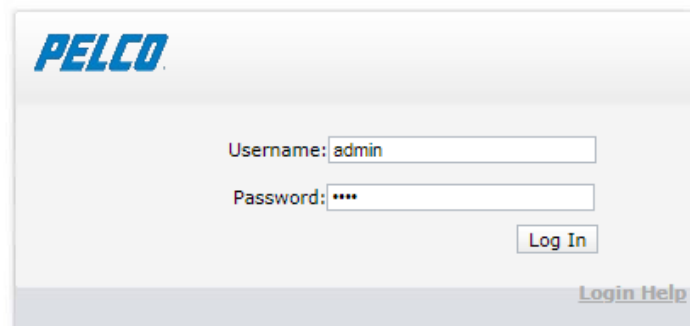

FIGURE 2-10: LOGIN WINDOW

NOTE: When connecting to the camera for the first time, or after restoring the camera's setting back to factory default, a user account must be created to enable access to video from the camera.

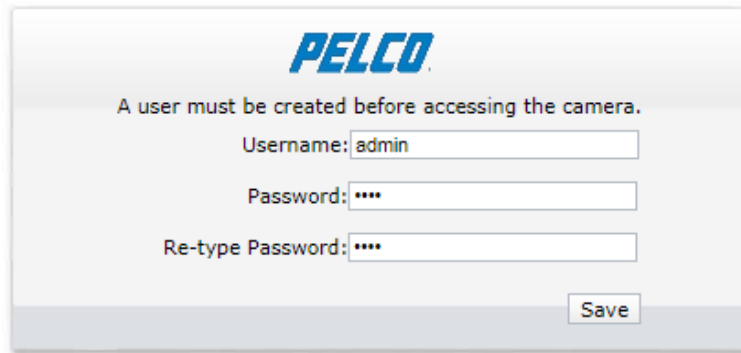

FIGURE 2-11: USER CREATION

1.2.2.3 Viewing Preparation

Images of the unit can be viewed through Microsoft Internet Explorer 9 or later. Before viewing, follow these steps to enable the display.

1. Enable Cookies On the **Privacy** tab, move the settings slider to **Low** or **Accept All Cookies**.
2. Change Security in **Internet options** and click **Custom Level** to open the **Security Settings – Internet Zone** screen.
NOTE: If the camera operates inside of the intranet, click the **Intranet** icon. If the camera operates outside of the intranet, click the **Internet** icon.
3. Scroll down to the ActiveX controls and plug-ins radio buttons and set as follows:
 - **【Download signed ActiveX controls】** → Prompt (recommended)
 - **【Download unsigned ActiveX controls】** → Prompt
 - **【Automatic prompting for ActiveX controls】** → Enable
 - **【Run ActiveX controls and plug-ins】** → Enable
 - **【Script ActiveX controls marked safe for scripting*】** → Enable
4. Press **OK** to save the settings.
5. Close all Microsoft Internet Explorer Windows and restart a new window. This will allow the new settings taking effect.
6. Type your setting IP address into the browser.
7. Then you should be able to see the camera image screen.

3. Administration and Configuration

3.1 Live

Simply click on **Live** on the top right side of the browser window while accessing the IP address of the unit, and a live video is displayed directly in the browser window. When clicking on **Settings**, a window will pop up for configuring “**System**”, “**Network & Security**”, “**Imaging**”, “**PTZ**”, “**A/V Streams**”, and “**Events**”. Please refer to **3.2 Settings on page 223** for more information. The current logged in identity shows to the right of the **Help**. Click on **Logout admin** of the administration window and configuration will return to the camera image screen.

* Figures of **3. Administration and Configuration** are taken for web interface introduction purposes only.

Following are the explanations to the tabs on the **Live** window.



QuickView Stream: Selects the image rate of the viewable video stream.



FIGURE 3-1: SELECT STREAM SETTINGS



Maximize Viewing Area: Scales the image to the full size of the browser.



Open Stream in New Window: Opens the video in a scalable, independent window. Opening the video in a separate window allows you to view the video while other applications are running. This window can be minimized, maximized, or closed using the title bar buttons of the active window. The window can also be resized to your specifications by dragging the lower-right corner of the window.



Snapshot: Capture a screenshot of what is seen currently on the live view image. A prompt message appears, after clicking the icon, to allow user to either open the screenshot or save the screenshot to a designated path.



Show Toolbar: Resizes the video pane to normal view.



FIGURE 3-2: LIVE VIEW

The PTZ control panel is used to conveniently execute pan/tilt/zoom functions on the live screen with ease. The figure and table below will provide you with more information to show how to execute PTZ controls under the panel easily.

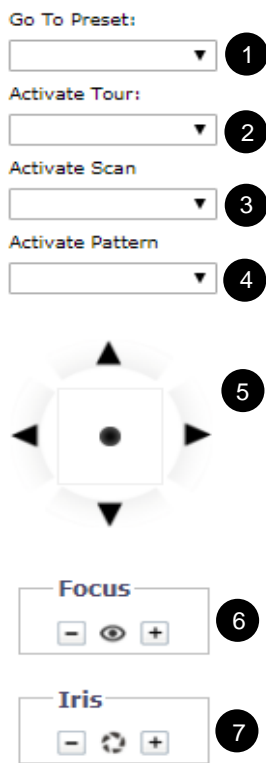

No	Descriptions
1	Select a Preset from the drop-down menu to make the selected preset be activated immediately.
2	Select a Tour from the drop-down menu to make the selected tour be activated immediately.
3	Select a Scan from the drop-down menu to make the selected scan be activated immediately.
4	Select a Pattern from the drop-down menu to make the selected pattern be activated immediately.
5	Click arrows to move camera in 4 directions manually. Also, pressing and holding the middle cursor can move camera in multiple desired ways.
6	Adjust focus to near/far distance by clicking +/-.
7	Adjust Iris value to be open/close by clicking +/-.

FIGURE 3-3: PTZ CONTROL PANEL

Under the live view screen, the zoom control panel helps users manipulate the zoom in/out functions with ease. Two methods are available for zoom control: Sliding & Up/Down Arrows Increment.

- **Sliding:** Drag the slider bar to zoom in/out of the camera view.
- **Up/Down Arrows Increment:** Simply click the up or down arrow to zoom in/out of the camera view by step.



FIGURE 3-4: ZOOM CONTROL PANEL

NOTE: The available max zoom scale is subject to digital zoom function. If digital zoom is turned on beforehand, the available zoom scale will be up to 360X (12X digital and 30X optical). On the other hand, if digital zoom is off, it will be up to only 30X optical zoom available for a user. Refer to **3.2.3.1 General** for more details about Digital Zoom.

3.2 Settings

Click on **Settings**, a window will pop up for configuring “**System**”, “**Network& Security**”, “**Imaging**”, “**PTZ**”, “**A/V Streams**”, and “**Events**”.

The screenshot displays the 'Settings: IP Camera-P2230-ESR-' window with the 'System' tab selected. The interface includes several sections: 'General Settings' with a 'Device Name' field; 'Time Settings' with radio buttons for 'None', 'DHCP', and 'Manual', a 'Time Zone' dropdown set to 'GMT', and a 'Display Format' dropdown; 'Text Overlay' with options for 'Background' (Black or Transparent) and 'Text Color' (Black), and a table for configuring content positions. The table has columns for 'Content Position' and 'Content'. The 'Live Preview' window shows a camera view of a building entrance with overlaid text: '04/09/2014 15:32:30 GMT-3' at the top right, 'IP Camera-IBP519-ER-T31580487' at the bottom left, and 'Bldg 21 -South parking lot' at the bottom right. At the bottom of the settings window are buttons for 'Save', 'Reset', 'Generate System Log', 'Reboot Camera', and 'Restore All Camera Defaults'.

Content Position	Content
<input type="checkbox"/> Top Left	Custom Text
<input type="checkbox"/> Top Right	Date/Time
<input type="checkbox"/> Bottom Left	Camera Name
<input type="checkbox"/> Bottom Right	Custom Text

Five lines maximum, use comma to switch line.
A maximum of 3 Content Positions may be selected

FIGURE 3-5: SETTINGS

3.2.1 System

Use the System tab to change the device name, configure the time settings, set up the text overlay for the live view, get backup, display system information, update the firmware version and manage the SD card storage (if an SD card is inserted in the slot). You can also use the System tab to generate a system log, reboot the camera, or to restore the camera's factory default settings.

System	Network	Imaging	PTZ	A/V Streams	Events
General Settings					
Backup & Restore	195				
Firmware	Camera-P2230-ESR-T81501412				
Storage Management					
Time Settings					
Time Server: <input type="radio"/> None <input checked="" type="radio"/> DHCP <input type="radio"/> Manual <input type="text"/>					
Time Zone: <input type="text"/> GMT <input type="text"/>					
Display Format: 04/25/2018 13:21:59 GMT <input type="text"/>					
Text Overlay					
Background: <input checked="" type="radio"/> Black <input type="radio"/> Transparent					
Text Color: <input type="text"/> Black <input type="text"/>					
Content Position		Content			
<input type="checkbox"/> Top Left	<input type="text"/> PTZ Direction/Pitch/Zoom <input type="text"/>				
<input type="checkbox"/> Top Right	<input type="text"/> Camera Name + Date/Time <input type="text"/>				
<input type="checkbox"/> Bottom Left	<input type="text"/> Camera Name <input type="text"/>				
<input type="checkbox"/> Bottom Right	<input type="text"/> Custom Text <input type="text"/>				
<small>Five lines maximum, use comma to switch line.</small>					
A maximum of 3 Content Positions may be selected					
<div style="display: flex; justify-content: space-between; align-items: center;"> <div> <input type="button" value="Save"/> <input type="button" value="Reset"/> </div> <div> <input type="button" value="Generate System Log"/> <input type="button" value="Reboot Camera"/> <input type="button" value="Restore All Camera Defaults"/> </div> </div>					

Live Preview

FIGURE 3-6: SYSTEM SETTINGS

Generate System Log

1. Click the System tab.
2. Click the Generate System Log button to create a system log that can be used by Pelco Product Support for troubleshooting.

Contact Pelco Product Support at 1-800-289-9100 (USA and Canada) or +1-559-292-1981 (international).

Reboot Camera

1. Click the System tab.
2. Click the Reboot Camera button to restart the camera. Rebooting the camera does not change the configured camera settings.

Restore All Camera Defaults

This process cannot be undone; all user and custom settings will be lost.

1. Click the System tab.
2. Click the Restore All Camera Defaults button to restore the camera's factory default settings.

NOTE: If the camera is not connected to a Dynamic Host Configuration Protocol (DHCP) network, the IP address settings for the camera will be lost and the server will not recognize the camera. DHCP On is the default setting for the camera IP address.

3.2.1.1 General Settings

General Settings

Device Name:

Time Settings

Time Server: None DHCP Manual

Time Zone:

Display Format:

Text Overlay

Background: Black Transparent

Text Color:

Content Position	Content
<input checked="" type="checkbox"/> Top Left	<input type="text" value="PTZ Direction/Pitch/Zoom"/>
<input checked="" type="checkbox"/> Top Right	<input type="text" value="Camera Name + Date/Time"/>
<input type="checkbox"/> Bottom Left	<input type="text" value="Camera Name"/>
<input type="checkbox"/> Bottom Right	<input type="text" value="Custom Text"/>

Five lines maximum, use comma to switch line.

A maximum of 3 Content Positions may be selected

Copyright © 2007-2018, PELCO, Pelco.com

FIGURE 3-7: GENERAL SETTINGS

General Settings

Change the Device Name by following steps:

1. Click the **Device Name** box and highlight the text.
2. Type a user-friendly name into the **Device Name** box (2 to 64 characters). A user-friendly name makes it easier to recognize the device on the network. Examples of user-friendly names are Front Door, Lobby, or Parking Lot.
3. Click Save to save the new device name, or click Reset to restore to the previously saved device name.

Time Settings

If the camera is connected to a **Dynamic Host Configuration Protocol (DHCP)** network that has time server properties configured, the camera will synchronize automatically with the time server. If the DHCP network's time server properties are not configured or the network does not have a time server, you need to configure the time settings manually.

1. Type the IP address of the time server in the **Time Server** field. The time server is an external server that uses **Network Time Protocol (NTP)** to synchronize the camera date and time settings.
2. Select the **Time Zone** option. Select the continent and the region that are closest to the camera's location from the **Time Zone** drop-down menus.

NOTE: If your location observes a form of daylight saving time, the system will automatically change the time on the associated dates.

3. Select the format in which the date and time will appear from the Display Format drop-down field if you have opted to show the Date/Time Overlay.
4. Click the Save button to save the settings, or click the Reset button to clear all of the information you entered without saving it.

Text Overlay

1. **Background:** Set the background color for the text overlay as black or transparent. Text color for the transparent background can be also customized from the drop-down menu when the transparent background option is selected.
2. **Content:** Five content options can be selected to display from the drop-down menu: Date/Time, Camera Name, Camera Name + Date/Time, Custom Text and PTZ Direction/Pitch/Zoom. The blank text field, which is for inputting desired text by users, shows only when Custom Text option is selected.
NOTE: Multiple content options can display simultaneously.
3. **Content Position:** Four positions can be selected to display content overlays: Top Left, Top Right, Bottom Left, and Bottom Right. A maximum of three positions can be enabled simultaneously.
4. Click the Save button to save the settings, or click the Reset button to clear all of the information you entered without saving it.

3.2.1.2 Backup & Restore

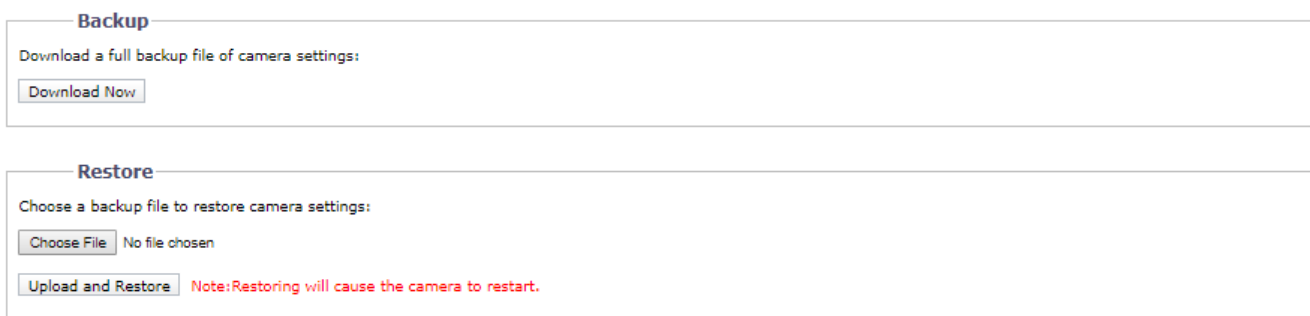

Backup
Download a full backup file of camera settings:

Restore
Choose a backup file to restore camera settings:
 No file chosen
 Note: Restoring will cause the camera to restart.

FIGURE 3-7: BACKUP AND RESTORE SETTINGS

Backup

Once the camera settings have been configured for optimal scene display, use the backup feature to save the camera settings.

Restore

If the camera settings are changed and inadvertently result in a less desirable image, use the restore setting to restore the camera to the previously saved settings.

NOTE: This feature is not intended for the configuration of multiple units or for firmware upgrades.

3.2.1.3 Firmware

The screenshot shows two sections. The first section, titled "System Information", contains four read-only fields: "Firmware Version: 05.20.1.8(MB:3.3)", "Hardware Version: 0000-A1.1-50901", "Model Number: P2230-ESR", and "Serial Number:". The second section, titled "Firmware Update", contains the instruction "Choose a ppm file to upgrade camera.", a "File Name:" label, a "Choose File" button, the text "No file chosen", and an "Upload" button.

FIGURE 3-9: SYSTEM INFORMATION AND FIRMWARE UPDATE SETTINGS

System Information

The System Information page fields are read-only and include the firmware version, hardware version, model number, and serial number of the system are revealed here as below figure. This information is typically required by Pelco Product Support for troubleshooting purposes.

Firmware Update

Users can update system firmware if available. Ensure a user has been created before updating camera's firmware. All camera motions will shut down during firmware update. Please close any other screens before firmware update. Never disconnect power or LAN cable during the firmware update process. It takes approximately 3 minutes for the unit to reboot after firmware update process. Again, power can't be lost when updating firmware since it will cause the update failure and manufacturer maintenance will be required.

3.2.1.5 Storage Management

The detailed information of an inserted SD card will be shown in this page where the device type, total capacity, free space and status are presented explicitly for users to preview. Also, the "Format Device" function is deployed here for further employment. Select either "vFAT" or "ext4" option from the Format Device dropdown menu, depending on preferred preference, and click on "Format" button to perform SD card format action.

The screenshot shows two sections. The first section, titled "Device Information", displays: "Device Type: SD Card - vfat", "Free Space: 1721(MB)", "Status: ok", "Total size: 7776(MB)", and "Full: No". The second section, titled "Device Setting", contains a "Format Device:" label, a dropdown menu with "ext4 (recommended)" selected, and a "Format" button.

FIGURE 3-10: STORAGE MANAGEMENT SETTINGS

3.2.2 Network & Security

Use the Network & Security tab to change the camera's general network settings, configure a user's management setting, select the Secure Sockets Layer (SSL) settings, enable Secure Shell (SSH), configure 802.1x port security settings, choose SNMP Server, Firewall mode, enable FTP access to this camera, and finally activate VMS Connectivity with the specific server-

System	Network	Imaging	PTZ	A/V Streams	Events
System Settings					
General					
Users & Security					
SSL					
SSH					
Hardware Address: 0	802.1x	Port: 80			
Hostname: F	SNMP	Port: 443			
HTTP Port: 8	Firewall	Port: 554			
HTTPS Port: 4	FTP				
RTSP Port: 5	VMS Connectivity				
IPv4 Settings					
DHCP: <input checked="" type="radio"/> On <input type="radio"/> Off					
IP Address: 172.20.20.78					
Subnet Mask: 255.255.255.0					
Gateway: 172.20.20.231					
Primary DNS: 0.0.0.0					
Secondary DNS: 0.0.0.0					
IPv6 Settings					
IPv6: <input type="radio"/> On <input checked="" type="radio"/> Off					
<input type="button" value="Save"/> <input type="button" value="Reset"/>					

FIGURE 3-11: NETWORK CONFIGURATION

3.2.2.1 General

Set the General Network Settings for network communication settings.

System Settings

Hardware Address: 00:04:7d:27:68:2e

Hostname:

HTTP Port: Default port: 80

HTTPS Port: Default port: 443

RTSP Port: Default port: 554

IPv4 Settings

DHCP: On Off

IP Address:

Subnet Mask:

Gateway:

Primary DNS:

Secondary DNS:

IPv6 Settings

IPv6: On Off

Configuration Mode: ▼

Link-Local Address:

Manual IP Address:
(one per line)

Manual DNS Servers:
(one per line)

Manual Gateways:
(one per line)

FIGURE 3-12: GENERAL NETWORK SETTINGS

System Settings

Settings under the System Settings are Hostname, HTTP Port, HTTPS Port, and RTSP Port. Contact your network administrator before changing port settings to ensure that your port settings do not conflict with your network infrastructure.

- **Hostname**
 1. Click in the **Hostname** box and highlight the text.
 2. Type a user-friendly name into the Hostname box (1 to 21 characters) using any combination of alphanumeric characters. A user-friendly name makes it easier to recognize the device on the network.
 3. Click the Save button to save the settings, or click the Reset button to clear all of the information you entered without saving it.
- **HTTP Port**

NOTE: The HTTP port number must remain at the default setting (80) when connecting to a Pelco video management system (VMS) platform. If connecting to a Pelco VMS, do not change the HTTP port setting.

 1. Click in the **HTTP Port** box and highlight the text.
 2. Type the new port number in the **HTTP Port** field. The default port for HTTP communications is **80**.
 3. Click the Save button to save the settings, or click the Reset button to clear all of the information you entered without saving it.
- **HTTPS Port**

NOTE: The HTTPS port is not configurable unless you have set SSL Mode to Optional or Required and installed a security

certificate.

1. Click in the **HTTPS Port** box and highlight the text.
2. Type the new port number in the **HTTPS Port** field. The default port for HTTPS communications is **443**.
3. Click Save. If you have changed the setting in error, you can click reset to revert to the previously saved setting.

- **RTSP Port**

1. Click in the **RTSP Port** box and highlight the text.
2. Type the new port number in the **RTSP Port** field. The default port for RTSP communications is **554**.
3. Click the Save button to save the settings, or click the Reset button to clear all of the information you entered without saving it.

IPv4 Settings

Enable or disable the **Dynamic Host Configuration Protocol (DHCP)** server. DHCP automatically assigns an IP address to the device if there is a DHCP server on the network.

- **If DHCP is set to On**, the IP address, subnet mask, gateway, and DNS server settings are read-only text.
- **If DHCP is set to Off**, these settings must be manually changed.

Change the following network settings as required:

1. **IP Address:** The address of the camera connected to the network.
2. **Subnet Mask:** The address that determines the IP network that the camera is connected to (relative to its address).
3. **Gateway:** The router that accesses other networks.
4. **DNS Servers:** The addresses of the dedicated servers that translate the names for Web sites and hostnames into numeric IP addresses.
5. Click the Save button to save the settings, or click the Reset button to clear all of the information you entered without saving it.

IPv6 Settings

Your device supports IPv6 in conjunction with IPv4 configurations; the device does not support IPv6-only network deployments. The device will accept up to sixteen IPv6 addresses, three IPv6 DNS servers, and three IPv6 gateways.

There are two configuration modes for IPv6 address assignments:

Auto: Enables automatic configuration using router advertisement. Additional configuration can be provided over DHCPv6 (if available on your network). Selecting Auto mode still allows you to manually configure additional IPv6 addresses, DNS servers, and gateways.

Manual Only: Provides a link-local IPv6 address for the device and allows you to assign up to 16 static IPv6 addresses to the device.

1. Place your mouse pointer over the Network tab.
2. Select General from the drop-down menu.
3. Select On for IPv6.
4. Select a Configuration Mode from the drop-down box. Selecting Auto allows the device to configure the remaining IPv6 settings automatically, rendering the remaining steps optional.
5. (Optional) Provide static, unicast addresses in the Manual IP Addresses box. Each address requires a prefix, and it must be input using the format prefix/IPv6Address. Manual IP addresses without prefix information will be rejected.
6. (Optional) Provide the addresses of DNS servers that are not configured automatically in the Manual DNS Servers box.

7. (Optional) Provide the addresses of gateways that are not configured automatically in the Manual Gateways box.

NOTES:

- The device will not accept multicast, localhost, or undefined IPv6 addresses.
- Link-local addresses are not supported for DNS.
- Manually specified DNS servers supersede automatically discovered DNS servers.
- Manually specified DNS servers are not validated by the device; verify any manually specified DNS servers before saving IPv6 settings.
- Manually specified gateways must be on the same network as the device's IPv6 addresses. Behavior for a gateway that is not on the same network as the device's IPv6 addresses is undefined.
- Some video management systems (VMS), including Pelco VMS systems, do not support connections to camera devices over IPv6.

3.2.2.2 Users & Security

Use the Users & Security tab to create and manage user accounts and to change the way the camera manages the user settings.

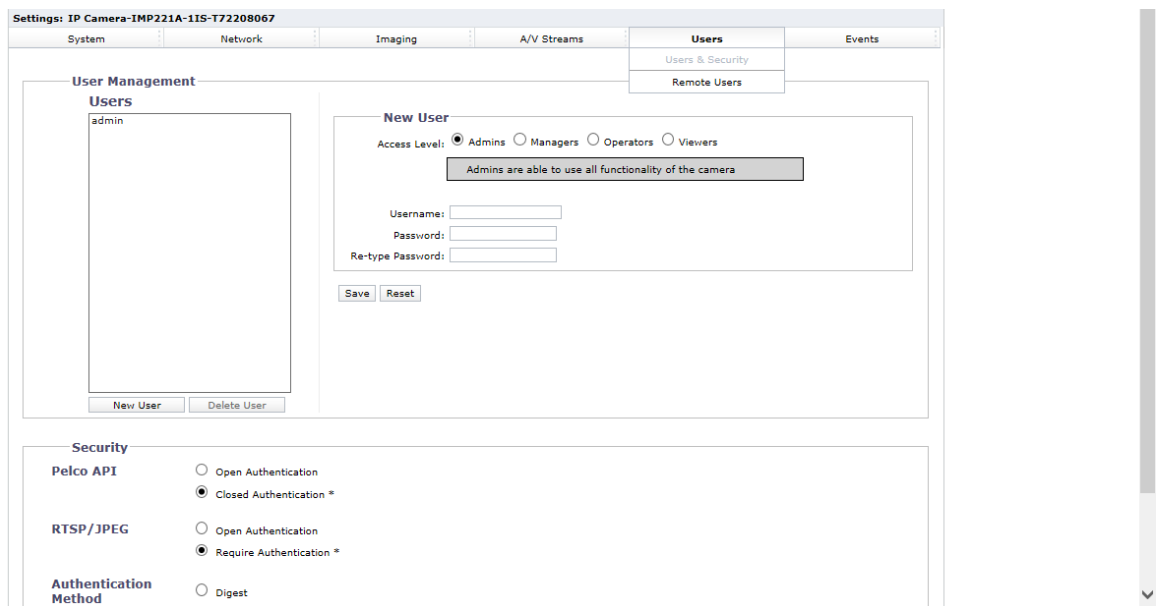

FIGURE 3-13: USERS CONFIGURATION

User Management

User accounts are created to limit the permissions of individuals who are logged onto the camera. The User Management page also includes four predefined access level settings that include Administrators, Managers, Operators, and Viewers permissions.

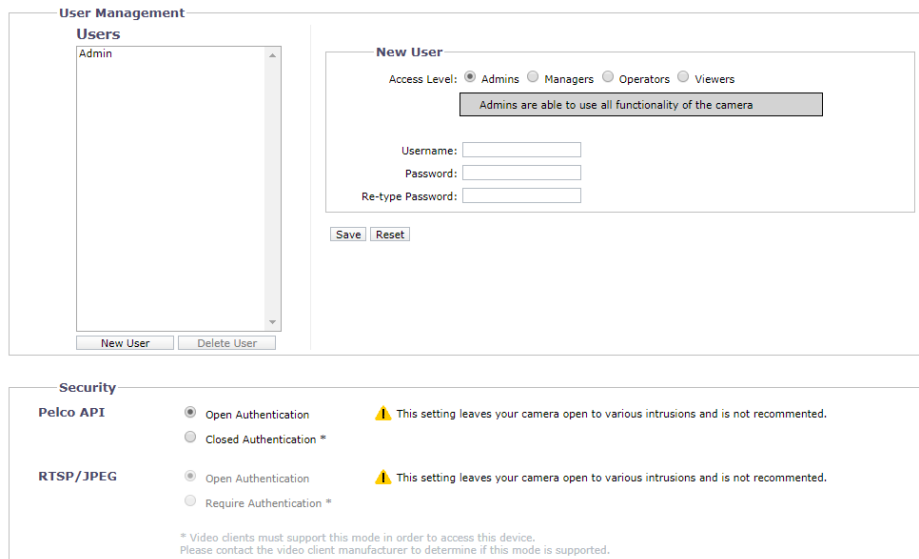

FIGURE 3-14: USERS & SECURITY

Creating a New User

Click **New User** button below the left box and Select the Access Level for the new user.

- **Access Level**

1. Select the Access Level for the user.
 - **Admins:** This is the only defined group that cannot be deleted. This group has access to all permissions.
 - **Managers:** This defined group can be modified or deleted. This group has access to all permissions except the permissions of access to the Users page and the restore factory defaults.
 - **Operators:** This defined group can be modified or deleted. The default permissions for this group are video stream view, PTZ manipulation as well as the use of API.
NOTE: PTZ manipulation permission varies by applicable models.
 - **Viewers:** This defined group can be modified or deleted. The default permissions for this group are limited within the video stream view and the use of API.
2. Click the Save button to save the settings and create a new user. The new user profile appears in the box on the left side of the page. Click the Reset button to clear all of the information you entered without saving it.

- **Username**

Click in the Username box and type a user name (2 to 23 alphanumeric characters). User names are case-sensitive.

- **Password**

Click in the Password box and type a password (4 to 16 alphanumeric characters). Passwords are case-sensitive.

- **Re-type Password**

Click in the Retype Password box and retype your password.

Click the Save button to save the settings and create a new user (the new user profile appears in the box on the left side of the page), or click the Reset button to clear all of the information you entered without saving it.

Deleting a User

1. Click the user profile that you want to delete from the defined users section located in the box on the left side of the page.
2. Click the Delete User button. A dialog box appears with the message “Are you sure you want to delete this user?”

3. Click OK. The user profile is deleted from the defined user profiles section.

NOTE: The default “admin” user cannot be deleted.

Security

● Pelco API

Select “Closed Authentication” will request video clients to conform to Pelco API (Application Programming Interface) protocol in order to access to the camera, while selecting “Open Authentication” will make API protocol of the camera fully open to various intrusions, which is not suggested due to security concerns.

● RTSP/JPEG

Select “Require Authentication” will request video clients to conform to RTSP (Real Time Streaming Protocol) or JPEG protocol in order to access to the camera, while selecting “Open Authentication” will make RTSP/JPEG protocol of the camera fully open to various intrusions, which is not suggested due to security concerns.

3.2.2.3 SSL

To ensure security on the Internet, all Web browsers provide several security levels that can be adjusted for sites that use SSL technology to transmit data. **SSL** encrypts communications, making it difficult for unauthorized users to intercept and view user names and passwords.

SSL requires signed certificates to determine if the Web browser accessing the camera has the required authentication. The camera can generate a certificate signing request (CSR) that can be sent to a certificate authority for a signature (for example, VeriSign®), or it can generate a self-signed certificate using the **Generate Self-Signed Certificate** option.

The screenshot shows a web interface for SSL configuration. It has two main sections: 'SSL Configuration' and 'Certificate'. In the 'SSL Configuration' section, there is a 'Mode:' label followed by three radio buttons: 'Disabled' (which is selected), 'Optional', and 'Required'. Below this is the 'Certificate' section, which contains the text 'No Certificate has been installed'. At the bottom of the interface, there are three buttons: 'Save', 'Reset', and 'Install New Certificate'.

FIGURE 3-15: SSL CONFIGURATION

SSL Configuration

Select one of the following modes:

- **Required:** A signed Secure Sockets Layer (SSL) certificate must be installed, and a secure URL that begins with the protocol name “https:” must be used to access the camera. Sensitive data is always encrypted during transmission. A URL that begins with the “http:” protocol rather than the “https:” protocol will be redirected to the secure URL automatically. **NOTE:** Beginning with firmware version 1.8.2, this field cannot be modified in the Web browser. To select or clear the required mode, you must use the ONVIF or Pelco API call. Doing so avoids placing the camera into a mode in which it would no longer work with a connected VMS system.
- **Optional:** A signed SSL certificate must be installed, but a secure URL that begins with the protocol name “https:” is optional when accessing the camera. You can also access the camera using a standard URL with the “http:” protocol, but sensitive data is not encrypted during transmission. To ensure that sensitive data is encrypted, you must use a secure URL with the “https:” protocol.
- **Disabled (default):** Turns off access to the Web client through SSL. Sensitive data will not be encrypted during transmission.

NOTE: If the SSL mode is set to disabled, you cannot access the camera using a URL that begins with an “https:” protocol. Your Web browser displays an error message if you do not type the camera URL correctly.

Refer to the following sections for more information:

- **Generating Self-Signed Certificate** on page 33
- **Generating Certificate Request** on page 33

Certificate

- **Generating Self-Signed Certificate**

1. Click the **Install New Certificate** button located at the bottom of the **SSL Configuration** page. The **Select Certificate Install Method** option buttons appear on the page.

Certificate
Select Certificate Install Method

Generate Self-signed Certificate
 Generate Certificate Request
 Upload Certificate

Next Cancel

Save Reset Install New Certificate

FIGURE 3-16: SELECT CERTIFICATE INSTALL METHOD OPTION

2. Select the “**Generate Self-signed Certificate**” option, and then click **Next**. The “**Self-signed Certificate Information Form**” opens.

Certificate
Generate Self-signed Certificate

Country Code:
2-letter country code, e.g: US

State/Province Name:
Full name of your state or province

City Name:

Common Name:
Hostname or IP address of this device

Organization Name:
e.g: Your company name

Organizational Unit Name:
e.g: Your department or section

Email Address:

Generate Certificate Cancel

FIGURE 3-17: GENERATING SELF-SIGNED CERTIFICATE CONFIGURATION

3. Fill in all of the fields, and then click **Generate Certificate**. The following progress message appears on the page: “Loading data...” After a while, the certificate is uploaded to the device.
4. After the certificate is uploaded, select the desired mode.
5. Click Save.

NOTE: Self-signed certificates are valid for one year. The certificate’s expiration date is listed in the Installed Certificate information section. If the certificate has expired and you attempt to access the camera using a secure URL, the Web browser displays a message. Repeat this procedure to generate and upload a new certificate.

- **Generating Certificate Request**

1. Click the **Install New Certificate** button located at the bottom of the **SSL Configuration** page. The **Select Certificate Install Method** option buttons appear on the page.
2. Select **Generate Certificate Request**, and then click **Next**. The “**Certificate Request Form**” opens.

FIGURE 3-18: GENERATING CERTIFICATE REQUEST

3. Fill in all of the fields, and then click **Generate Request**. The following progress message appears on the page: “Generating certificate signing request, please wait...”
4. Send the CSR, which looks like an encrypted block of undecipherable text, to a third-party certificate authority of your choice for a signature.
5. After you receive the signed certificate, click the Install Certificate button to upload the signed certificate to the device.
6. After the certificate is uploaded, select the desired mode.
7. Click Save.

NOTE: Depending on the third-party certificate authority that signed your certificate, you might need to renew your certificate after a specified amount of time. Consult the certificate authority for more details.

- **Upload Certificate**

1. Click the **Install New Certificate** button located at the bottom of the SSL Configuration page. The Select Certificate Install Method option buttons appear on the page.
2. Select **Upload Certificate**, and then click **Next**. The “**Certificate**” opens.

FIGURE 3-19: UPLOAD CERTIFICATE

3. Choose the Certificate you want to upload and then click **Upload** button. The following progress message appears on the page: “Loading data...”
4. After the certificate is uploaded, select the desired mode.
5. Click Save.

- **Delete Certificate**

1. Once you successfully upload a certificate, **Delete Certificate** button will appears at the bottom of the SSL Configuration page.
2. If you want to delete the certificate, click the **Delete Certificate**. The following progress message appears on the page: “Deleting certificate file...”
3. Click Save.

3.2.2.4 SSH

SSH is a user-enabled protocol that allows Pelco Product Support to log on to and service the camera for advanced troubleshooting purposes.

From this page, users with the appropriate permissions can enable or disable SSH access to the camera.

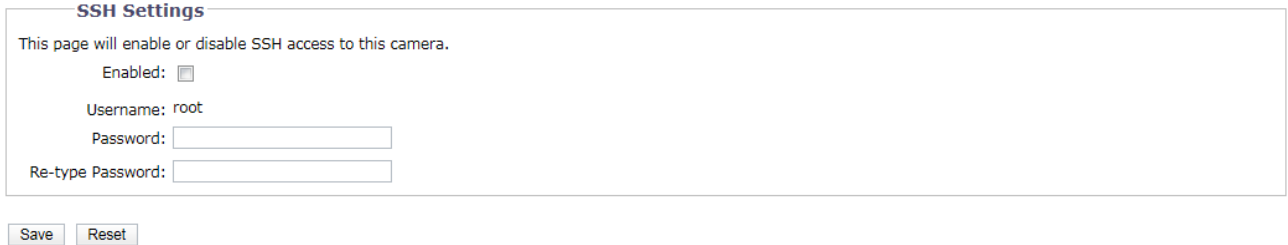

FIGURE 3-20: ENABLING SECURE SHELL

SSH Settings

1. Select the **Enabled** check box.
2. Click in the **Password** box and type a password (4 to 16 alphanumeric characters). Passwords are case-sensitive.
NOTE: The default username is “root” and cannot be changed. The username and password are required when accessing the camera through a third-party SSH client.
3. Click in the “**Re-type Password**” box and retype your password.
4. Click the Save button to save the password and enable SSH, or click the Reset button to clear all of the information you entered without saving it.

3.2.2.5 802.1x

802.1x is a port security that authenticates devices that want to establish a point-to-point access through a wired or wireless port using Extensible Authentication Protocol (EAP). This port-based authentication method prevents unauthorized access to a Local Area Network (LAN) through a physical port. For example, when a device is connected to a network port, the network switch will ask the device for authentication.

If the credential is accepted when the device sends a credential to the network switch, the network switch will open the port for normal use.

If authentication fails, the device is prevented from accessing information on the port.



FIGURE 3-21: CONFIGURING THE 802.1X PORT SECURITY SETTINGS

802.1x Port Security

WARNING: To prevent network conflicts, contact your network administrator before configuring the 802.1x port security settings.

1. Select the **On** option for the 802.1x Port Security. The default setting for 802.1x is **Off**.
2. Select the Extensible Authentication Protocol (EAP) method from the Protocol drop-down menu. Supported EAP methods include **EAP-MD5**, **EAP-TLS**, **EAP-TTLS**, and **EAP-PEAP**.

3. Type the information required for the selected 802.1x authentication method.
4. Connect the PC to an 802.1x secured switch that has the same **EAP** method.
5. Click the Save button to save the settings, or click the Reset button to clear all of the information you entered without saving it.

3.2.2.6 SNMP

SNMP is an application layer protocol used to manage TCP/IP-based networks from a single workstation or several workstations. The camera supports SNMP versions 2c and 3 and can be configured to send data using a trap.

FIGURE 3-22: SNMP CONFIGURATION

SNMP Configuration

WARNING: The Simple Network Management Protocol (SNMP) settings are advanced controls. Consult your network administrator to obtain the required information to configure SNMP settings.

- **No SNMP Server**
None disables the SNMP configuration and is the default setting.
- **CONFIGURING SNMP V2C**
 1. Select **V2c** as the SNMP Version.
 2. Type the community name in the Community String box. The default name for the Community String is “public.”
 3. Configure the Trap Configuration settings.
 - **Address:** Type the host name or IP address of the recipient of the trap message.
 - **Community String:** Type the name of the community that should receive the trap message.
 4. Click the Save button to save the settings, or click the Reset button to clear all of the information you entered without saving it.
- **CONFIGURING SNMP V3**
 1. Select **V3** as the SNMP Version.
 2. Type the SNMP user name in the **SNMP User** field.
 3. Select the encryption algorithm for authentication from the **Authentication** drop-down menu: None, MD5, or SHA. If you use authentication method MD5 or SHA, type a password in the text box to the right of the selected Authentication encryption.
 4. Select the privacy encryption algorithm setting from the **Privacy** drop-down menu: None, DES, or AES. If you use

privacy method DES or AES, type a password in the text box to the right of the selected Privacy encryption.

5. Configure the address for the **Trap Configuration**. The Address is the host name or IP address of the recipient of the trap message.
6. Click the Save button to save the settings, or click the Reset button to clear all of the information you entered without saving it.

NOTE: SNMP V2c and SNMP V3 configuration settings are independent of each other, but only one SNMP version can be active at a time.

3.2.2.7 Firewall

Set the **Firewall** function. A firewall is a system or group of systems that manages access between two networks.

Firewall

Mode: ▼

<input type="checkbox"/> Enabled	Address 1: <input type="text"/>
<input type="checkbox"/> Enabled	Address 2: <input type="text"/>
<input type="checkbox"/> Enabled	Address 3: <input type="text"/>
<input type="checkbox"/> Enabled	Address 4: <input type="text"/>
<input type="checkbox"/> Enabled	Address 5: <input type="text"/>
<input type="checkbox"/> Enabled	Address 6: <input type="text"/>
<input type="checkbox"/> Enabled	Address 7: <input type="text"/>
<input type="checkbox"/> Enabled	Address 8: <input type="text"/>
<input type="checkbox"/> Enabled	Address 9: <input type="text"/>
<input type="checkbox"/> Enabled	Address 10: <input type="text"/>

FIGURE 3-23: FIREWALL CONFIGURATION

Firewall

1. Select **Allow** or **Deny** mode to enable this function. The default setting is **Off**.
2. Check **Enable** to enter IP Address in the **Address** field. Up to ten addresses can be enabled for entry.
3. Click the Save button to save the settings, or click the Reset button to clear all of the information you entered without saving it.

3.2.2.8 FTP

This page will enable or disable **FTP** access to this camera. In this page, users can activate a FTP Server to access the SD card for recordings. **Enabled** the **FTP** and use this function.

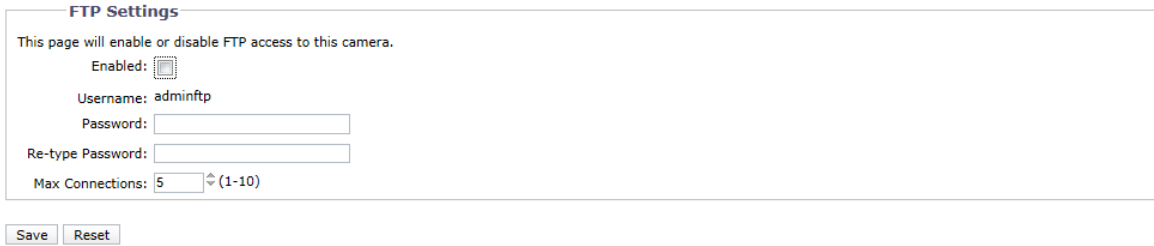

The screenshot shows a web form titled "FTP Settings". At the top, it says "This page will enable or disable FTP access to this camera." Below this, there is a checkbox labeled "Enabled:" which is checked. Underneath, the "Username:" is set to "adminftp". There are two input fields for "Password:" and "Re-type Password:". At the bottom, there is a "Max Connections:" field with a dropdown menu showing "5" and a range "(1-10)". At the very bottom of the form are two buttons: "Save" and "Reset".

FIGURE 3-24: FTP SETTINGS

FTP Settings

1. Select the **Enabled** check box to activate the FTP function. Use the following procedures to set up related settings.
2. Enter a **Username** if activating the FTP function.
3. Enter a **Password** associated with the **Username**.
4. **Re-type Password** to confirm it.
5. Set the number of maximum connections by entering a number in the **Max Connections** field.

NOTE: This is the maximum number of FTP Client connections, not the maximum number of IE Window's connections.

3.2.2.9 VMS Connectivity

This page allows specific configuration of connectivity to either the Endura VMS system to the standard protocol that conforms to the regulations of IP security surveillance data for transmitting, transferring and monitoring within the PRC (People Republic of China).

The screenshot shows two main configuration sections: 'Endura Connectivity' and 'GB/T-28181 Settings'. The 'Endura Connectivity' section has two radio button options: 'Listen for Endura SM system availability broadcast' (selected) and 'Associate with specific Endura SM system'. Below the first option is a 'Current SM IP Address association' field, and below the second is an 'SM IP Address' field. The 'GB/T-28181 Settings' section includes an 'Enable' toggle set to 'On', and input fields for 'Server Address', 'Port' (set to 5060), 'Device ID', 'Password', and 'Alarm ID'. At the bottom, there are 'Heartbeat Interval' and 'Register Interval' fields, both set to 60. At the very bottom of the form are 'Save' and 'Reset' buttons.

FIGURE 3-25: VMS CONNECTIVITY SETTINGS

Endura Connectivity

1. Choose **Listen for Endura SM system availability broadcast** to automatically associate with the available SM IP address currently.
2. Select **Associate with specific Endura SM system** followed by filling in the field of **SM IP Address** below to manually customize a preferred setting for association.

NOTE: Endura Connectivity section is not supported in P2820-ERS model.

GB/T-28181 Settings

1. Select the **On** check box to activate the GB/T-28181 connectivity function.
2. Enter an address for **Server Address** and a value for **Port** ranging from 1025 – 65535.
3. After registering the GB28181 service, enter a **Device ID** and an associated **Password**.
4. A set of alarm ID will be obtained after registering the GB28181 service. Input the provided alarm ID, which is for alarm notice, into the field here.
5. Set an interval value for **Heartbeat** and **Register** transmits with the server individually.

3.2.3 Imaging

Use the Imaging tab to change the camera's general image settings, adjust the camera exposure, program the white balance mechanism, or define window blanking privacy areas.

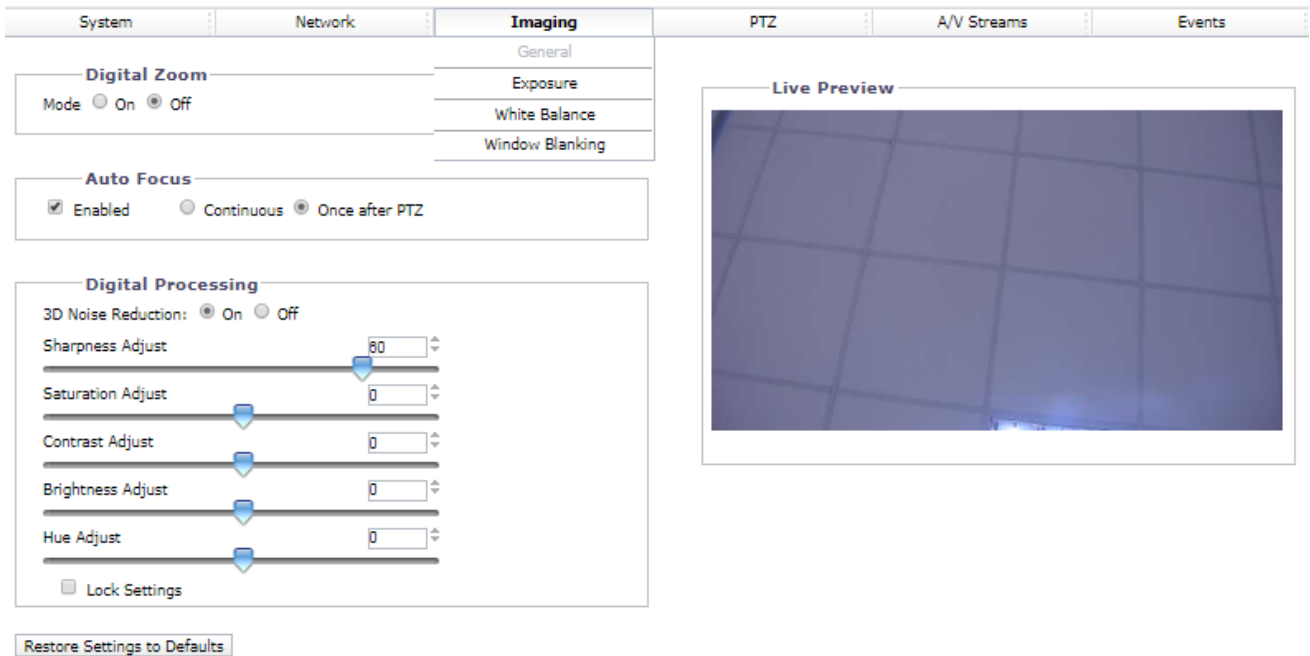

FIGURE 3-26: IMAGING SETTINGS

3.2.3.1 General

General imaging settings include adjustments for camera orientation and digital processing.

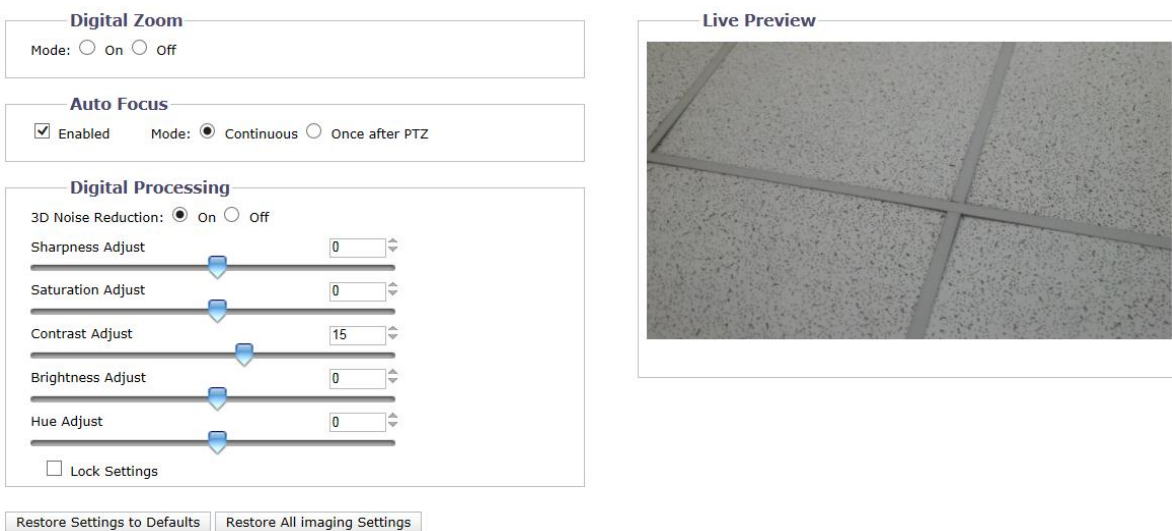

FIGURE 3-27: GENERAL IMAGING SETTINGS

Digital Zoom

Turn On to enable digital zoom, which will increase the available zoom scale to 360X (optical 30X and digital 12X).

Auto Focus

Click to enable auto focus. "Continuous" means the camera will continue to focus during PTZ operations. "Once after PTZ" means that the camera will not begin to focus until the PTZ movement has stopped.

Digital processing

Digital processing settings can adjust the camera's sharpness, saturation, contrast, brightness and hue.

Move the slider to the left or right to change the following settings:

- **Sharpness:** Controls the clarity of detail in a scene. Move the slider to the right to increase the sharpness; move the slider to the left to decrease the sharpness. Increasing the sharpness also increases the image noise. The range of adjustment is -100 to 100; the default setting is 0 (zero).
- **Saturation:** Controls how intense or vivid the colors are in a scene. Move the slider to the right to increase the saturation level; move the slider to the left to decrease the saturation level. The range of adjustment is -100 to 100; the default setting is 0 (zero).
- **Contrast:** Controls gradations between the darkest and lightest portions of the scene. Move the slider to the right to increase the contrast; move the slider to the left to decrease the contrast. The range of adjustment is -100 to 100; the default setting is 0 (zero).
- **Brightness:** Controls the lighting detail in a scene. Move the slider to the right to lighten the image; move the slider to the left to darken the image. The range of adjustment is -100 to 100; the default setting is 0 (zero).
- **Hue:** Controls the color in a scene. Move the slider to the right to achieve a cool color image; move the slider to the left to achieve a warm color image. The range of adjustment is -100 to 100; the default setting is 0 (zero).

Check **Lock Settings** box to lock the Digital processing settings listed above.

3.2.3.2 Exposure

Exposure is the amount of light detected by the camera sensor. A scene with correct exposure settings has adequate detail and contrast between white and dark values. An image with too little or too much exposure eliminates detail in the scene. The camera features Exposure and Day/Night settings.

Exposure

Priority Low Noise ▾

- Max Exposure Time: 200 msec
- Max Gain: 48 db
- Smoothness will vary with light level.

Flicker Correction

Line Frequency: 1/60 ▾

Basic Setting

True WDR: Off ▾ ⓘ

BLC: Off ▾

Day / Night

Auto

IR Illumination

Transition Level: Lighter Default Darker

Transition Detect Time(sec) 10

Manual

Position: Day Night Night w/IR Illumination

[Restore Settings to Defaults](#)

Live Preview



FIGURE 3-28: EXPOSURE SETTINGS

Exposure

- **Priority**

Select **Motion** or **Low Noise** to exposure in different values of **Max Exposure Time** and **Max Gain**.

- **Flicker Correction**

Flickering by fluorescent light can be reduced by selecting “50Hz” if the power frequency is 50Hz, “60Hz,” if 60Hz.

Basic Setting

- **True WDR**

Select On to enable True WDR. This technology is intended to provide a clear image even under the backlight circumstance where intensity of illumination can vary excessively; namely both extreme bright and dark areas exist simultaneously in the field of view. True WDR is a sensor-based technology that achieves proper exposure levels by capturing short and long exposures individually and combining them into a single frame to render a superior detail of image quality. Note that when True WDR is enabled, the maximum frame rate will be forcibly decreased to 30fps if it was selected above 30fps originally. **NOTE:** True WDR is only possible when the Exposure Priority setting is set to Motion,

- **BLC**

Select an area ranging from Upper, Lower, Central 1/3rd, Central 1/6th, Left, and Right for Backlight Compensation. Backlight Compensation is a function that sets the brightness of a selected area to an optimal level. This function is necessary when an auto iris lens tends to close quickly due to an intense light coming from the back of object in the area they wish to view, resulting in the area being too dark and difficult to see. In this case, users may set the area corresponding to the portion they wish to see.

NOTE: Central 1/6th option is not supported in P2820-ERS model.

Day/Night

The Day Night Auto mode setting automatically controls the day/night switch depending on the Transition Level and Transition Detect Time settings.

- **Auto**

1. **IR Illumination:** Enable IR Illumination to allow the camera automatically turns on/off the IR light based on whether the camera status is Night/Day mode respectively. When IR Illumination is disabled the IR light is off no matter the camera is in Day or Night mode.
2. **Transition Level:** Determines when the camera changes from day mode (color) to night mode (black-white). Select a lighter transition level setting if you want the camera to change modes at a high lux setting. Use the default setting for normal day/night operation. Use a darker transition level to change modes at a low lux setting.
3. **Transition Detect Time (sec):** Controls the length of time the camera is exposed to a light level before it changes to color or black-white mode.
This setting is useful for dark scenes where a bright light is momentarily introduced in the scene (for example, when a car with its headlights turned on passes the camera scene).

- **Manual**

1. **Day:** If **Day** mode is selected, the camera is forced to stay in **Day** mode all day.
2. **Night:** If **Night** mode is selected, the camera is forced to stay in **Night** mode all day.
3. **Night w/IR Illumination:** If this mode is selected, the camera is forced to stay in **Night** mode all day with, **IR light on**.

3.2.3.3 White Balance

Under **White Balance**, choose from **Auto** and **Manual** modes of adjustment on white balance for the video. **Auto** enables automatic controls on color temperature ranging from 2500°K to 10000°K.



FIGURE 3-29: WHITE BALANCE SETTINGS

Under **Manual** mode, the Red and Blue Gain adjustment bars with their scale boxes on their right will appear once the mode is selected. Base color of the video will change as the bars are adjusted left or right. Adjust to the ideal balance as appears to fit. Click on **One Push** to have the camera adjust to the proper gain values rapidly depending on the ambient environment of the area viewed, where its light source is constant, without adjusting for any change in light source or color temperature.

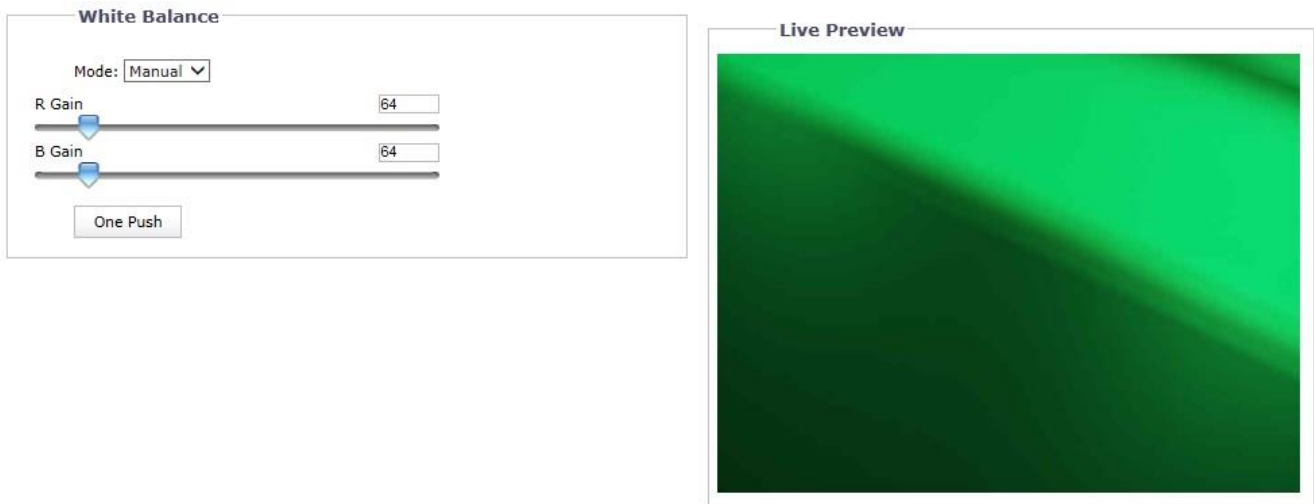

FIGURE 3-30: WHITE BALANCE SETTINGS – MANUAL

3.2.3.4 Window Blanking

Window blanking is used to conceal user-defined privacy areas. A blanked area appears on the screen as a solid gray window. The camera can handle up to eight blanked windows as long as the total blanked area does not exceed 50 percent of the field of view.

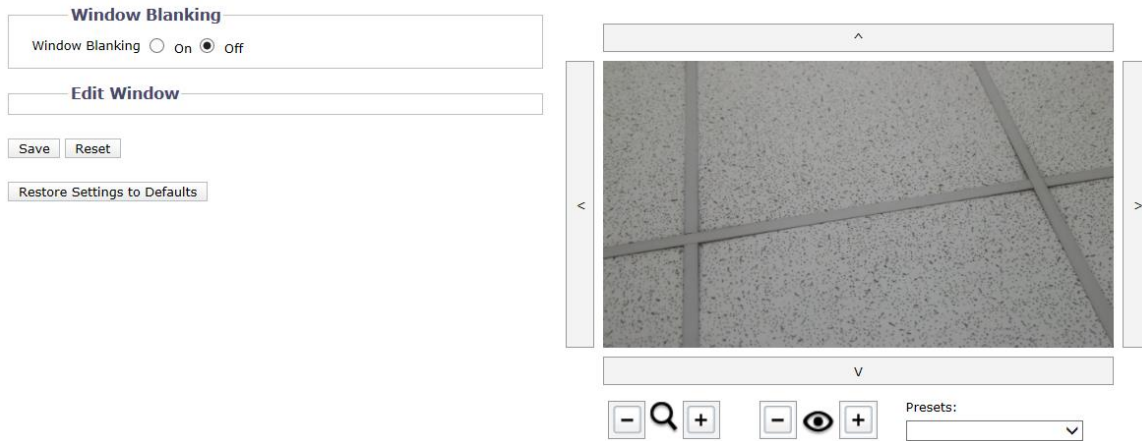

FIGURE 3-31: WINDOW BLANKING SETTINGS

Window Blanking

- **Window Blanking On**

1. Draw a window in the Live Preview area of the page:
 - a. Hold down the left mouse button.
 - b. Drag the mouse diagonally across the area you want to blank.
 - c. A color-coded box appears in the Edit Window section of the page that is the same color as the window drawn in the Live Preview area.

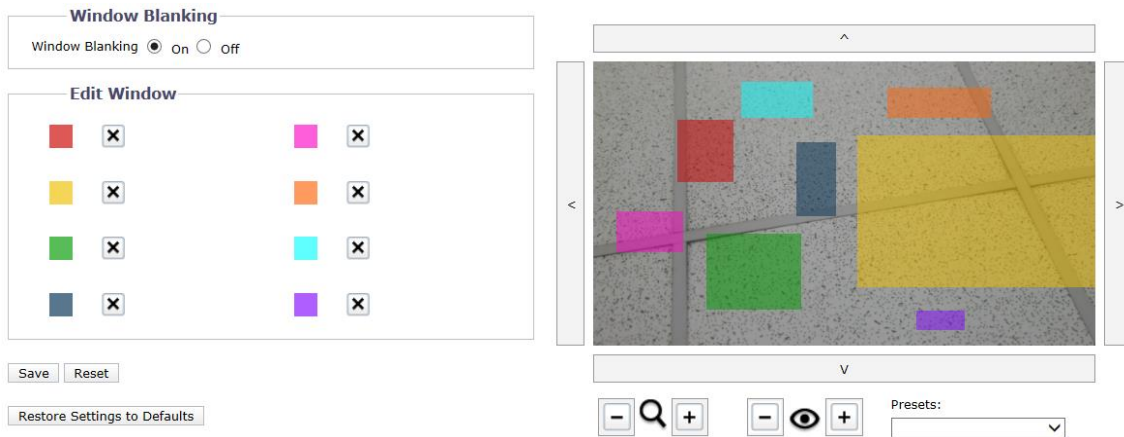

FIGURE 3-32: WINDOW BLANKING ON

NOTE: Up to 8 blanked windows can be defined, but the blanked area cannot exceed 50 percent of the field of view.

2. To resize the window, click and drag one or more of the points until the window is the desired shape and size.
3. Also, a user can adjust focus near/far and zoom in/out by clicking + and - individually for a desired location.
4. In addition, the Presets drop-down menu allows a user to locate the camera to predefined positions.
5. Click the Save button to save the settings, or click the Reset button to clear all of the information you entered without saving it.

Editing Window

- **Deleting a Window Blanking Area**
 1. In the Edit Window area of the page, click the Delete button next to the window blanking area you want to delete.
 2. Click the Save button to save the settings, or click the Reset button to clear all of the information you entered without saving it. Click the Restore Settings to Defaults to make the camera go back to the factory default settings.

- **Window Blanking Off**
 1. Select the Off option for Window Blanking.
 2. Click the Save button to save the settings, or click the Reset button to clear all of the information you entered without saving it. Click the Restore Settings to Defaults to make the camera go back to the factory default settings.

3.2.4 PTZ

Here a user will be guided through configurations for various types of PTZ operations including PTZ movements (pan, tilt, zoom and focus); and actions (Scan, Preset, Patrol and Pattern).

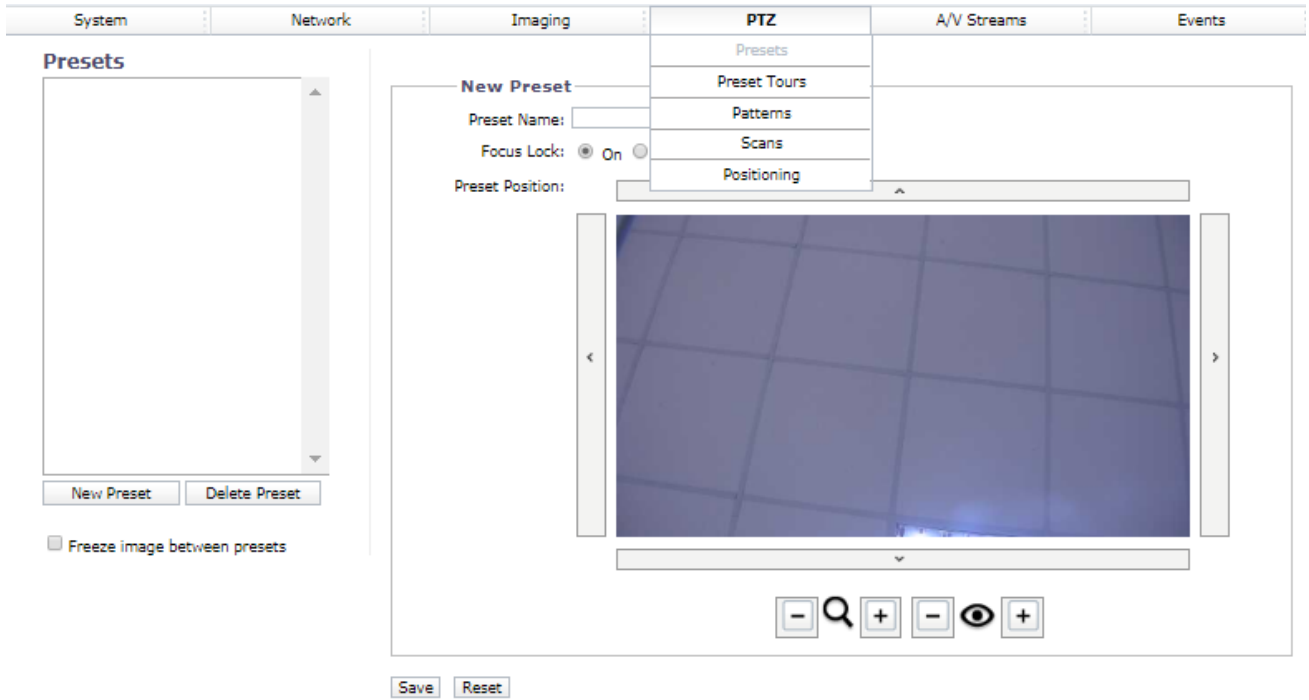

FIGURE 3-33: PTZ SETTINGS

3.2.4.1 Presets

The preset settings page configures presets, which are predetermined viewing areas (such as doors) that a device goes to automatically when instructed, either by an operator giving a simple command or a software program issuing an instruction.

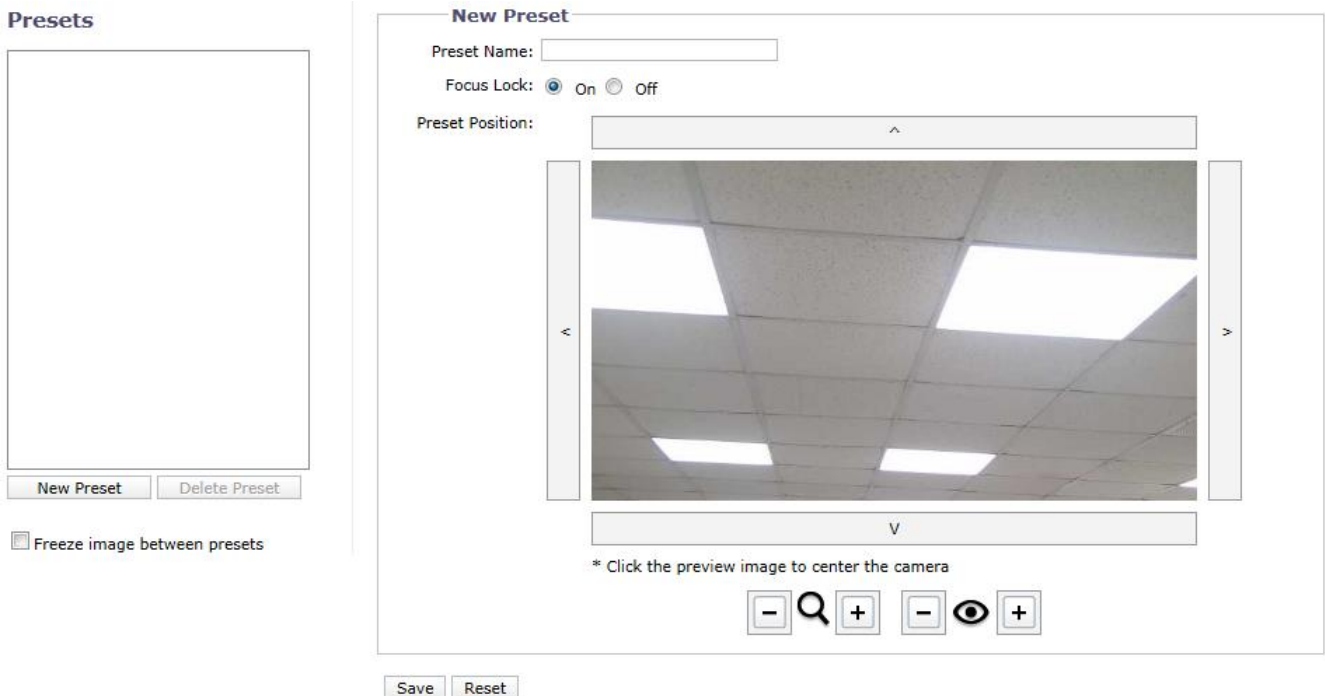

FIGURE 3-34: PRESETS SETTINGS

Edit Preset

- **Preset Name**

Enter a preferred name into the text field for preset.

- **Focus Lock**

Select On to fix the focus of the selected preset, which indicates that focus won't be adjusted when the preset changes.

- **Preset Position**

Use the 4 directional arrows to move the camera view location. Also, a user can adjust the focus near/far and zoom in/out by clicking + and - individually for a desired position. After naming a preset followed by determining an ideal position, click the Save button to save the settings, or click the Reset button to clear all of the information you entered without saving it.

Presets

The left-side list box lists all the presets created by the user. Simply click on one of the presets to move focus into the desired place. Additionally, the user can modify those presets via clicking on the desired preset, modifying the location and name in the right-side window, and then clicking Save.

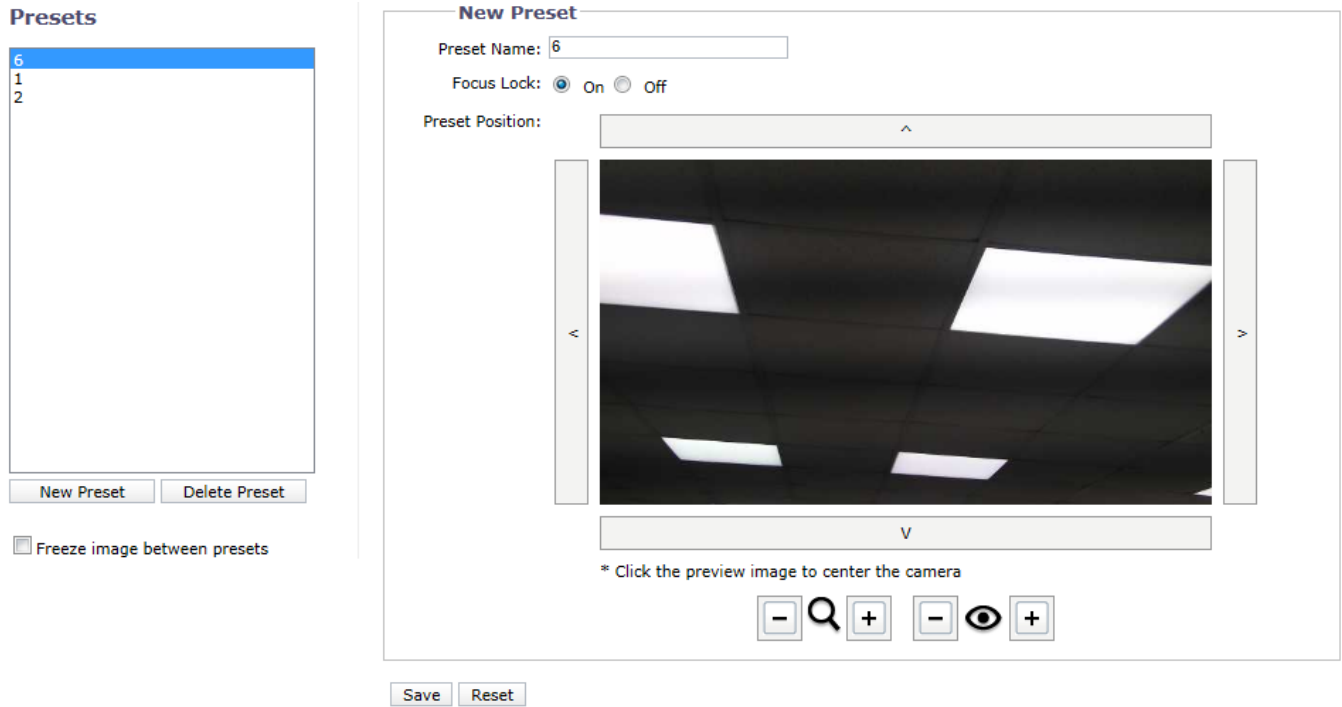

FIGURE 3-35: PRESETS LIST SETTINGS

- **New Preset**
Click New Preset to create a new one. The right-side window will be a new preset page with clear info.
- **Delete Preset**
Choose one of the presets from the list and click Delete Preset to remove unwanted preset.
- **Freeze image between presets**
Check the box to enable the camera to freeze images between presets, which freezes the live view before moving to a new preset and unfreezes the view after the camera is pointed at the new preset. By contrast, the full live views during movement will be seen if a user unchecks this function. The default setting is unchecked.

3.2.4.2 Preset Tours

After defining presets, a user can further set a group of several presets to build up a preset tour under this page. For agile and efficient surveillance around every critical corner, it is practical to fully manipulate this feature by the PTZ camera.

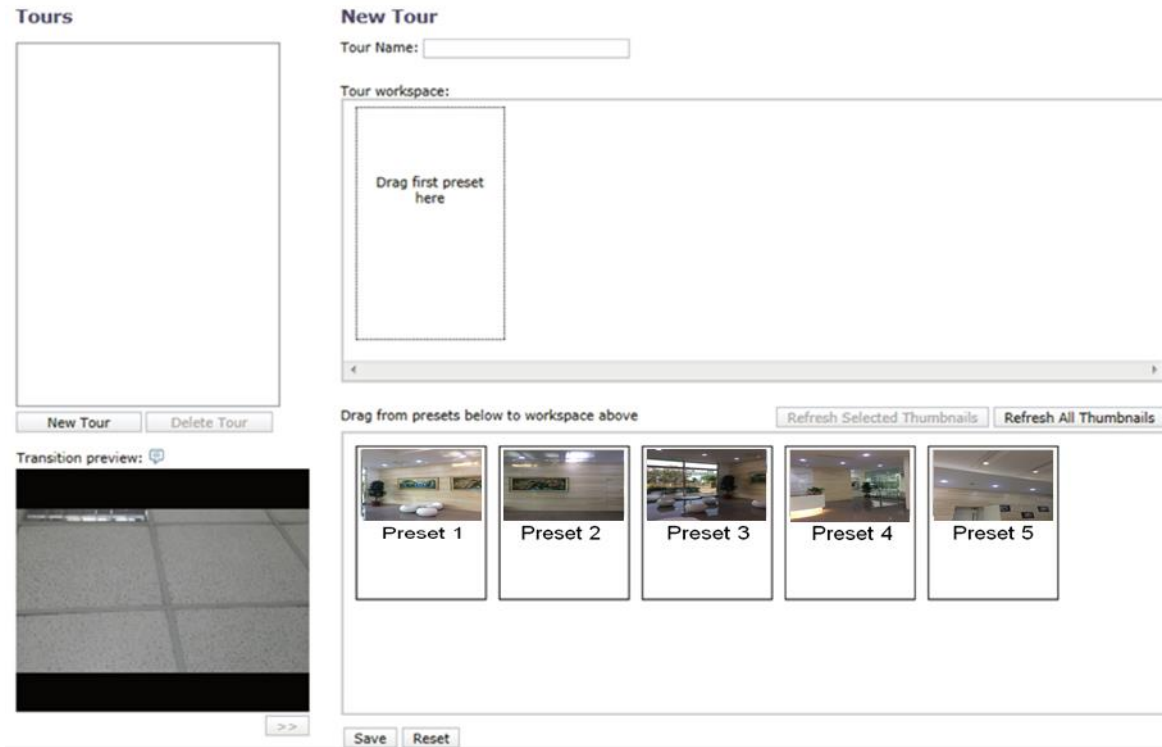

FIGURE 3-36: PRESETS TOUR SETTINGS

New Tour

- **Tour Name**
Enter a preferred name into the text field for tour group.
- **Tour Workspace**
This section includes all desired presets to group a tour. A user can drag wanted presets from the lower section “Drag from presets below to workspace above” and drop to this section. The “Dwell” allows a user to set the interval between presets and the “Transition Speed”, which consists of 6 levels, controls the speed of camera from a preset to next preset. The “X” icon next to preset name is for deleting preset from this section.
- **Drag from presets below to workspace above**
This section contains all the presets that a user set in the previous “Preset” page.
- **Refresh All Thumbnails**
Click this button to update to the latest snapshots for all presets. After clicking, the camera will instantly move through all of the presets to capture new images.
- **Refresh Selected Thumbnails**
Click this button to simply update snapshots of those presets chosen by user.
- After naming a new tour and successfully adding wanted presets into the workspace section, click the Save button to save

the settings, or click the Reset button to clear all of the information you entered without saving it.

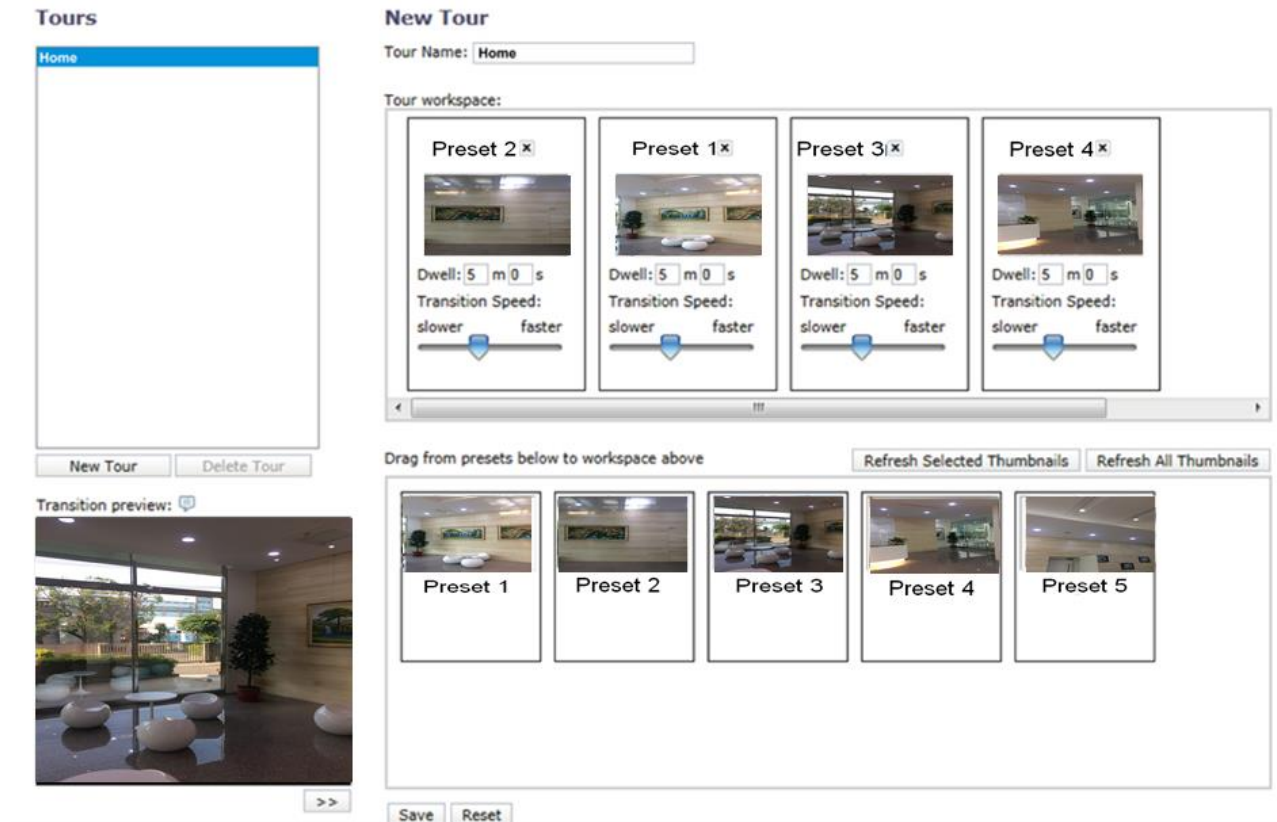

FIGURE 3-37: PRESETS TOUR LIST SETTINGS

Tours

The left-side list box shows all the tours created by a user. Simply click on one of the tours to proceed with a group of presets. Additionally, it is available for a user to edit/modify tours via clicking on one of the desired tours first, and user can freely add or delete presets within “Tour workspace” in the right-side window.

- **New Tour**

Click New Tour to create a new tour. The right-side window will then be a new tour page with clear info.

- **Delete Tour**

Choose one of the tours from the list and click Delete Tour to remove an unwanted tour.

- **Transition preview**

The lower-left screen shows transition preview between each selected preset within a tour. The icon  under the preview screen is for user to play the selected presets one by one, step by step.

NOTE: A tour name must be between 1 to 64 characters and each tour name should be unique. In addition, the max number of tours to be set is 16 simultaneously and each tour is limited to contain a maximum of 32 presets.

3.2.4.3 Patterns

Pattern action memorizes camera series of up to 128 pan, tilt, zoom and Presets operations to be automatically and regularly repeated later on when the Pattern is activated. By default the focus and iris are in auto status during the time pattern is being memorized.

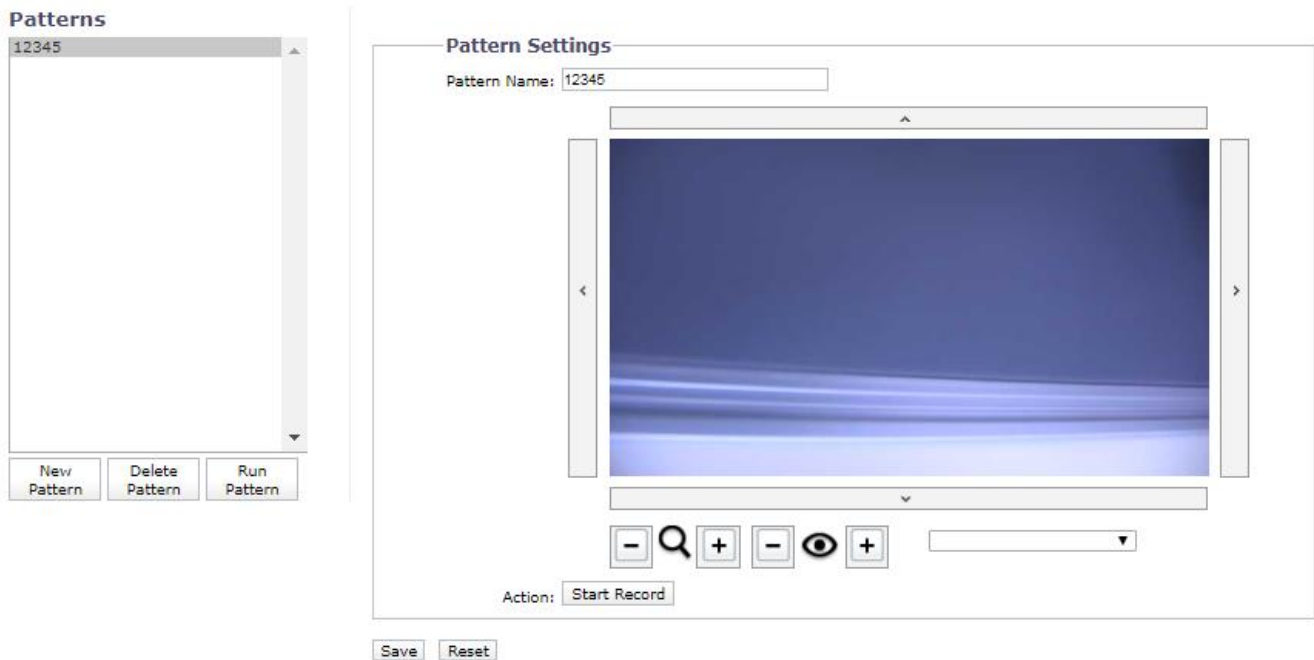

FIGURE 3-38: PATTERNS SETTINGS

New Pattern

- **Pattern Name**
Enter a preferred name into the text field for pattern.
- **Pattern Recording**
Start by clicking the Start Record button to start recoding a pattern. Use the 4 directional arrows or select a preset from the dropdown button to move the camera view location. Also, a user can adjust the focus near/far and zoom in/out by clicking + and - individually for a desired position. After performing a set of actions to determine ideal positions, click the Stop button and then Save button to save the settings, or click the Reset button to clear all of the information you entered without saving it.

Patterns

The left-side list box lists all the patterns created by the user. A user can modify those patterns via clicking on the desired pattern, and then modifying the location and name in the right-side window, and then clicking Save.

- **New Pattern**
Click New Pattern to create a new one. The right-side window will be a new pattern page with clear info.
- **Delete Pattern**
Choose one of the patterns from the list and click Delete Pattern to remove unwanted pattern.
- **Run Pattern**

Choose one of the patterns from the list and click Run Pattern to activate the desired pattern.

3.2.4.4 Scans

Scan action allows the camera to automatically pan back and forth regularly within a specified limit, at constant moving speed, and with predefined and constant tilt, zoom and focus values. In Scan action, the whole covered scene (sequence of views) is being monitored repeatedly,

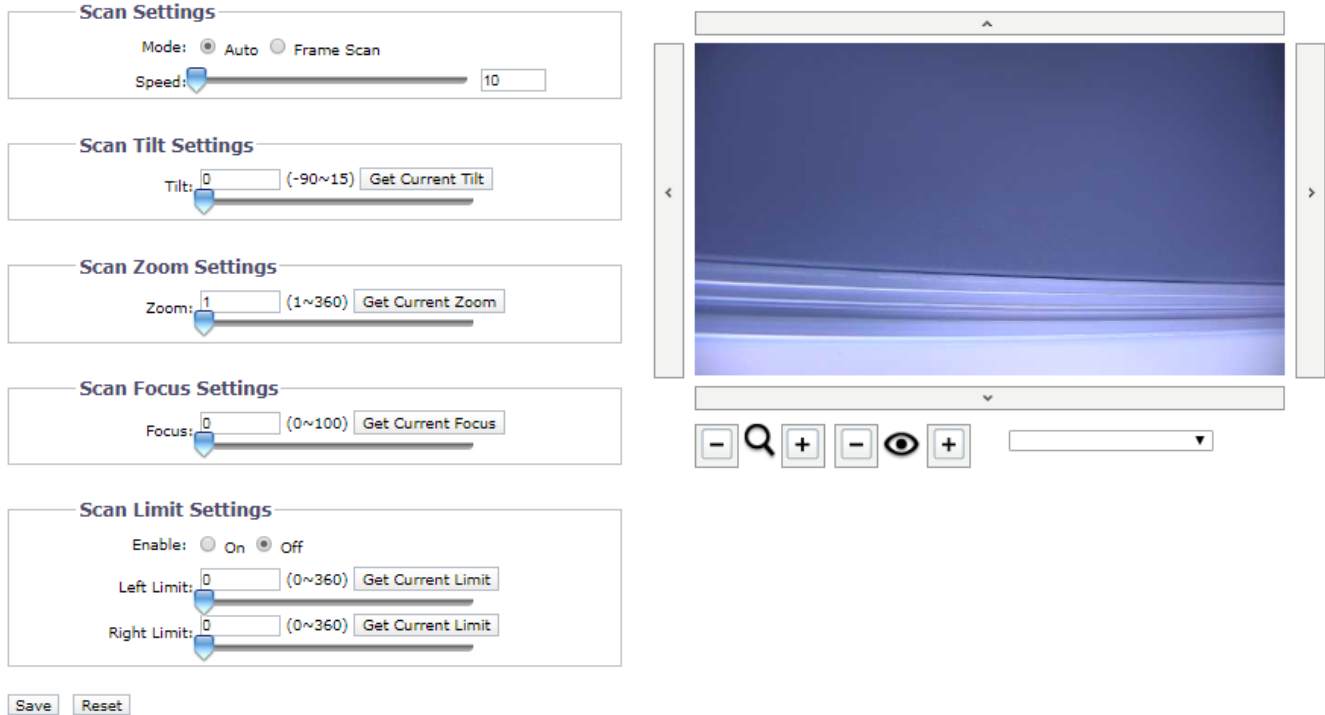

FIGURE 3-39: PATTERNS SETTINGS

Scan Settings

- **Mode**

Auto Scan: Camera will pan back and forth regularly with predefined tilt, zoom and focus.

Frame Scan: Beginning at the left limit, your camera will pan one frame at a time toward the right limit, at the specified speed and dwell for the specified amount of time. When the right limit is reached, the camera will move back toward the left limit. If limits are not set, the camera will start from its current position pan one frame to the right indefinitely. Tilt and zoom are not affected by this feature.

Speed: Allows the user to define the pan moving speed for Scan action. Higher values mean faster speed.

Scan Tilt Settings

- **Tilt**

Drag and adjust the bar or enter a value for setting the tilt angle for Scan action.

Scan Zoom Settings

- **Zoom**

Drag and adjust the bar or enter a value for setting the zoom depth for Scan action.

Scan Focus Settings

- **Focus**

Drag and adjust the bar or enter a value for setting the focus depth for Scan action.

Scan Limit Settings

User can specify left and right limits on Pan action of Scan operations and let the camera focus only on important scenes.

- **Enable**

Enable limit by setting On.

- **Left Limit**

Drag and adjust the bar or enter a value for setting the left limit.

- **Right Limit**

Drag and adjust the bar or enter a value for setting the right limit.

3.2.4.5 Positioning

This page largely broadens the extensive functions of PTZ controls. By setting limits for pan/tilt stops, it helps a user customize a certain range of field of view without unwanted areas. Additionally, a user can define what action the camera is about to operate when powered on and having been parking for a certain period.

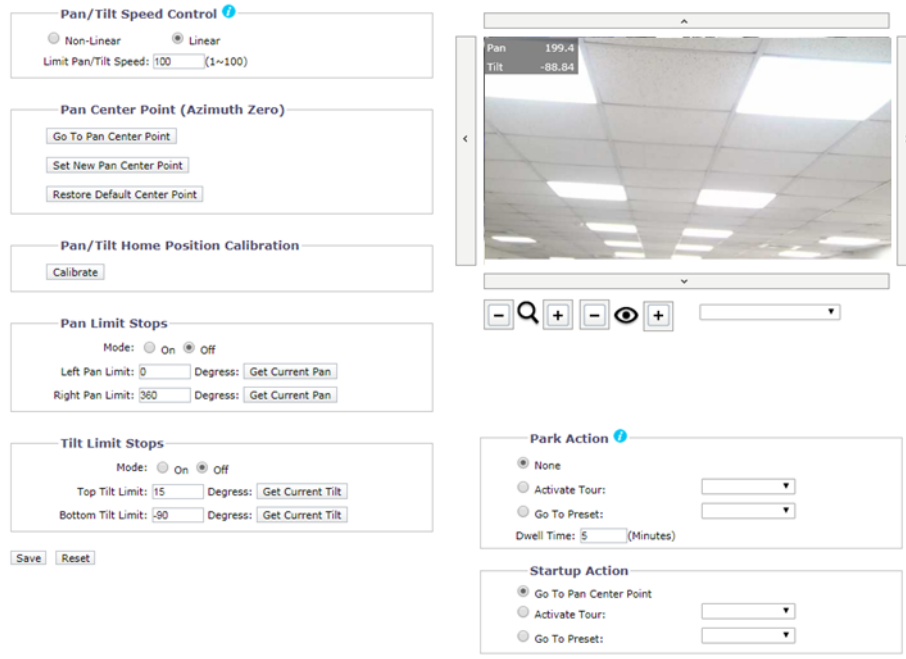

FIGURE 3-40: POSITIONING SETTINGS

Pan/Tilt Speed Control

- **Linear / Non-Linear**

Select the Linear option to enable linear speed control, which means the speed of pan/tilt operating starts in a slow way and advances up evenly to faster and faster speeds. By contrast, the Non-Linear option makes camera move from slow to fast speed in a rapid way, instead of a gradual step.

- **Limit Pan / Tilt Speed**

Input a value into the field to define a speed limit for pan & tilt movements. The value is measured in a percent of the maximum value supported by the camera.

Pan Center Point

- **Go To Pan Center Point**

Click the button to make the camera move to the user-defined central point of pan (Azimuth Zero position of 360 degree rotation).

- **Set New Pan Center Point**

Click the button to set the current camera position as the central point of pan.

- **Restore Default Center Point**

Click the button to cause the camera to restore to the factory default central point of pan.

Pan/Tilt Home Position Calibration

- **Calibrate**

Click the button to fix Pan/Tilt shift caused by shock or vibration by returning Pan/Tilt back to home position.

Pan Limit Stops

Select “On” to enable this feature, which allows a user to specify a range of pan limit between 2 defined Azimuth positions.

- **Left Pan Limit**

Input numeric text into the field to define the desired degree of left-side pan limit.

- **Get Current Pan (Left)**

Press the button to enable the entered numeric text as the left-side pan limit.

- **Right Pan Limit**

Input numeric text into the field to define the desired degree of right-side pan limit.

- **Get Current Pan (Right)**

Press the button to enable the entered numeric text as the right-side pan limit.

Tilt Limit Stops

Select “On” to enable this feature, which allows a user to specify a range of tilt limit between 2 defined Azimuth positions.

- **Top Tilt Limit**

Input numeric text into the field to define the desired degree of top-side tilt limit.

- **Get Current Tilt (Top)**

Press the button to enable the entered numeric text as the top-side tilt limit.

- **Bottom Tilt Limit**

Input numeric text into the field to define the desired degree of bottom-side tilt limit.

- **Get Current Tilt (Bottom)**

Press the button to enable the entered numeric text as the bottom-side tilt limit.

Park Action

This feature enables the camera to operate a Tour or a Preset after a period of time when camera hasn't received any operational command from a user. The period of time before activation can also be customized.

- **None**

Select None to disable park action. (Default settings)

- **Activate Tour**

Select Activate Tour and choose a tour from the drop-down menu to be operated after camera has parked without action for a period.

- **Go to Preset**

Select Go to Preset and choose a preset from the drop-down menu to be operated after camera has parked without action for a period.

- **Dwell Time**

To define how many minute(s) the camera has parked without any action before operating a Tour or a Preset.

Startup Action

This feature enables the camera to operate a Tour / Preset or move back to the pan central point when powered on.

- **Go to Pan Center Point**

Camera will move to the defined central point when powered on. Refer to ***Pan Center Point*** for more details about center point.

- **Activate Tour**

Select Activate Tour and choose a tour from the drop-down menu to be operated when camera is powered on.

- **Go to Preset**

Select Go to Preset and choose a preset from the drop-down menu to be operated when camera is powered on.

Preview Window

The preview screen with control panel is basically identical to the Presets page. The user can move the camera using the four arrows and manipulate zoom in/out or focus near/far by individual + and - buttons. Furthermore, the “Presets” drop-down menu here allows a user to move to set desired positions rapidly.

3.2.5 A/V Streams

Use the A/V Streams tab to configure the video and audio streams for the camera. The A/V Streams tab includes the Video Configuration page, the Audio Configuration page, the Local Recording page, the RTP Settings page, and the Smart Compressions page.

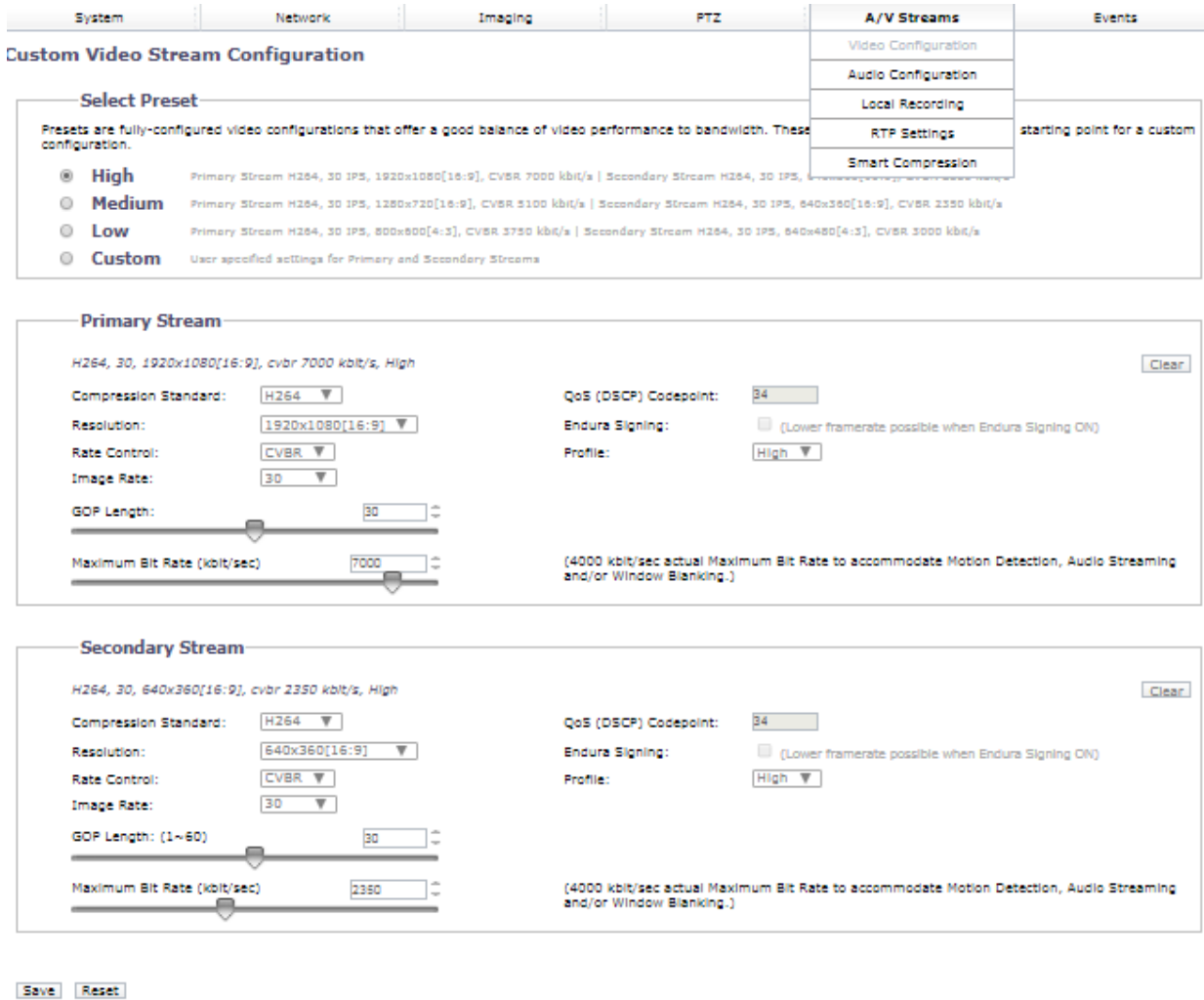

FIGURE 3-41: A/V STREAMS SETTINGS

3.2.5.1 Video Configuration

The Video Configuration page allows a user to customize the compression, resolution, rate control, image rate, GOP length, Qos codepoint, Endura Signing, and profile of the video streams. The default names for the streams are Primary Stream and Secondary Stream. Although each stream can be configured independently, the settings of one stream can limit the options available to the other stream, depending on the processing power used.

NOTE: Always configure the primary stream before the secondary stream. The primary stream should always be the most resource-intensive of the streams.

Custom Video Stream Configuration

Select Preset

Presets are fully-configured video configurations that offer a good balance of video performance to bandwidth. These presets may also be used as a starting point for a custom configuration.

- High** Primary Stream H264, 30 IPS, 1920x1080[16:9], CVBR 7000 kbit/sec | Secondary Stream H264, 5 IPS, 1280x720[16:9], CVBR 1750 kbit/sec
- Medium** Primary Stream H264, 30 IPS, 1280x720[16:9], CVBR 5100 kbit/sec | Secondary Stream H264, 15 IPS, 1024x576[16:9], CVBR 3500 kbit/sec
- Low** Primary Stream H264, 30 IPS, 1024x576[16:9], CVBR 5000 kbit/sec | Secondary Stream H264, 15 IPS, 640x352[16:9], CVBR 1200 kbit/sec
- Custom** User specified settings for Primary and Secondary Streams

Primary Stream

H264, 30, 1024x576[16:9], CVBR 5000 kbit/sec, High Clear

Compression Standard: QoS (DSCP) Codepoint:

Resolution: Endura Signing: (Lower framerate possible when Endura Signing ON)

Rate Control: Profile:

Image Rate:

GOP Length:

Maximum Bit Rate (kbit/sec)

Secondary Stream

MJPEG, 30, 1024x576[16:9], Mid Clear

Compression Standard:

Resolution:

Quality:

Image Rate:

FIGURE 3-42: CUSTOM VIDEO STREAM CONFIGURATION

Select Preset

Presets are fully-configured video configurations that offer a good balance of video performance to bandwidth. These presets may also be used as a starting point for a custom configuration.

- **High:** Primary Stream H264, 30 IPS, 1920x1080[16:9], CVBR 7000 kbit/sec | Secondary Stream H264, 5 IPS, 1280x720[16:9], CVBR 1750 kbit/sec.
- **Medium:** Primary Stream H264, 30 IPS, 1280x720[16:9], CVBR 5100 kbit/sec | Secondary Stream H264, 15 IPS, 1024x576[16:9], CVBR 3500 kbit/sec.
- **Low:** Primary Stream H264, 30 IPS, 1024x576[16:9], CVBR 5000 kbit/sec | Secondary Stream H264, 15 IPS, 640x352[16:9], CVBR 1200 kbit/sec.
- **Custom:** User specified settings for Primary and Secondary Streams.

Primary Stream

Select Custom in Select Preset and configure Primary Stream.

- **Compression Standard**
 1. **H264:** A new version of MPEG-4 compression used in high-definition video players such as Blu-ray™ and HD-DVD. H.264 is the most processor-intensive compression.
 2. **H.265:** An improvement of H.264 that provides better compression efficiency while improving image quality and lowering processor workload.
 3. **MJPEG:** A commonly used video compression scheme. MJPEG has the least impact on the camera's processor, but it requires the most bandwidth.

- **Resolution**

Refer to the following table for the resolution capabilities of your camera model.

NOTE: Resolution for 2688x1520 and above are supported only in P2820-ERS model.

TABLE 3-1. CORRELATIONS OF RESOLUTIONS COMPRESSIONS STREAMS

Compression Standard Available Resolutions	Primary Stream			Secondary Stream		
	H264	H265	MJPEG	H264	H265	MJPEG
3840x2160	3840x2160	3840x2160	3840x2160	640x360	640x360	640x360
3264x1840	3264x1840	3264x1840	3264x1840	1920x1080 1280x720 1024x576 960x540	1920x1080 1280x720 1024x576 960x540	1920x1080 1280x720 1024x576 960x540
2688x1520	3840x2160	3840x2160	3840x2160	1920x1080 1280x720 1024x576 960x540	1920x1080 1280x720 1024x576 960x540	1920x1080 1280x720 1024x576 960x540
1920x1080	1920x1080	1920x1080	1920x1080	1280x720 1024x576 960x540 640x352 320x180	1280x720 1024x576 960x540 640x352 320x180	1280x720 1024x576 960x540 640x352 320x180
1280x720	1280x720	1280x720	1280x720	1280x720 1024x576 960x540 640x352 320x180	1280x720 1024x576 960x540 640x352 320x180	1280x720 1024x576 960x540 640x352 320x180
1024x576	1024x576	1024x576	1024x576	1024x576 960x540 640x352 320x180	1024x576 960x540 640x352 320x180	1024x576 960x540 640x352 320x180
960x540	960x540	960x540	960x540	960x540 640x352	960x540 640x352	960x540 640x352

				320x180	320x180	320x180
640x352	640x352	640x352	640x352	640x352 320x180	640x352 320x180	640x352 320x180
320x180	320x180	320x180	320x180	320x180	320x180	320x180

- **Rate Control**

The rate control setting affects the actual bit rate and quality of each frame in the video stream.

1. **CBR:** The constant bit rate (CBR) streams video at a fixed number of bits per second.
2. **CVBR:** The Constant Variable Bit Rate (CVBR) streams video at a variable number of bits per second.
Select **CVBR** Rate Control. CVBR Maximum Bit Rate (kbit/sec) slider will appear.

- **Image Rate**

The image rate is the number of images per second (ips) available for the video stream configuration. Available image rates are 60, 50, 30, 25, 20, 16.67, 15, 12.5, 10, 7.5, 5, 3, 2 and 1.

NOTE: The maximum image rate setting might not be obtainable due to the programmed compression standard and the resolution of the stream.

- **GOP Length**

Select the GOP length from 1 to 60 (depending on selected Image Rate value. A larger GOP length results in greater compression of the video and lower bit rates consuming less network bandwidth. However, large GOP lengths can also result in dropped frames. A smaller GOP length results in less compression of the video but yields higher bit rates consuming more network bandwidth. This setting is only available in H.264 and H265.

- **CBR Bit Rate (kbit/sec)**

Selecting constant bit rate (CBR) streams video at a fixed number of bits per second. CBR uses the full capacity of the bit rate setting for scenes with or without motion. Video is always streamed at the user bit rate setting.

When CBR is selected as the Rate Control option the Bit Rate adjustment slider will be used to specify the fixed number of bits per second.

- **CVBR Maximum Bit Rate (kbit/sec)**

Selecting the constrained variable bit rate (CVBR) provides high-quality video and long recording time of variable bit rate while limiting variations in recording capacity consumption.

When CVBR is selected as the Rate Control option the Bit Rate adjustment slider will be used to set the maximum bit rate.

- **QoS (DSCP) Codepoint**

Quality of Service (QoS) for Differentiated Services Code Point (DSCP) is a code that allows the network to prioritize the transmission of different types of data. This setting is only available with H264 and H265.

NOTES:

1. If you are not familiar with DSCP, contact your network administrator before changing this setting.
2. Your network must be configured to use QoS. If you are unsure if your network is QoS-aware, contact your network administrator.

- **Endura Signing**

Enabling the Endura Signing feature allows an Endura® system to authenticate video from an Endura recorded stream. This setting is only available with H.264 and H265.

NOTE: Endura Signing is not supported in P2820-ERS model.

- **Profile**

The profile defines the subset of bit stream features in H.264 and H265 streams, including color reproduction and additional video compression. It is important that the selected profile is compatible with the recording device so that a stream can be decoded and viewed.

1. **Main:** An intermediate profile with a medium compression ratio. Main is the default profile setting. This profile is compatible with most recorders and uses fewer bits to compress video than the baseline profile; however, it uses more bits than the high profile. The main profile supports I-frames, P-frames, and B-frames.
2. **High:** A complex profile with a high compression ratio. This is the primary profile for high-definition television applications; for example, this is the profile adopted for Blu-ray and HD-DVD. The high profile supports I-frames, P-frames, and B-frames.

Secondary Stream

Select Custom in Select Preset and configure Secondary Stream. Repeat Primary Stream setting steps for the Secondary Stream settings.

3.2.5.2 Audio Configuration

The Audio Configuration page allows you to setup the audio device. The default setting for Audio is disabled, which means that no audio is transmitted from the camera. When enabled, audio is transmitted from the camera to the PC. Based on your system configuration, images and audio may not be synchronized.

NOTE: Improper use of audio/visual recording equipment may subject you to civil and criminal penalties. Applicable laws regarding the use of such capabilities vary between jurisdictions and may require, among other things, express written consent from the recorded subjects. You are solely responsible for insuring strict compliance with such laws and for strict adherence to any/all rights of privacy.



FIGURE 3-43: AUDIO CONFIGURATION

Audio In

- **Enabled**
Set to **Enabled** when receiving audio from a microphone plugged into the unit.
- **Disabled**
Set to **Disabled** to close **Audio In**.

Encoding

Choose from two audio codecs: **G711-Alaw/G711-Ulaw**

Level

The sound levels are selectable from Low, Mid and High.

NOTE: Changes to these settings cause video to restart.

3.2.5.3 Local Recording

Local Recording enables users to record and save video files locally on the SD card inserted, instead of recording and saving them over the network that will occupy a huge portion of memory and bandwidth. Check to enable this type of recording. Note that once the card is full, the oldest and previously-recorded video files on the card will be overwritten when the option “**Enable Continuous Recording**” is checked.



FIGURE 3-44: LOCAL RECORDING

3.2.5.4 RTP Settings

Multicast

Here a user can configure multicast RTP streams. RTP is a common way of transmitting and synchronizing surveillance system video and audio streams over RTSP session. Multicast provides the most efficient usage of bandwidth when there are large numbers of clients viewing simultaneously.

Multicast

Primary Video Stream
Address: 239.168.0.20
Port: 3126 [0, 1024..65534; even values]
Time to Live (TTL): 10 [1..255]
 Always Multicast this stream

Audio Stream
Address: 239.168.0.20
Port: 2090 [0, 1024..65534; even values]
Time to Live (TTL): 10 [1..255]
 Always Multicast this stream

Secondary Video Stream
Address: 239.168.0.20
Port: 3892 [0, 1024..65534; even values]
Time to Live (TTL): 10 [1..255]
 Always Multicast this stream

Restore Default Multicast Settings Revert to previous Multicast Settings Save

TCP/IP
Max. Transfer Unit (MTU): 1450 [576..1500]

Restore Default TCP/IP Settings Revert to previous TCP/IP Settings Save

FIGURE 3-45: RTP SETTINGS

Primary Video Stream

- **Address:** Set the multicast address for RTP video streaming.
- **Port:** Set the multicast port number for RTP video streaming to an even number in the range 1024 to 65534. To disable the port set value to 0.
- **Time to Live (TTL):** Set the effective scope of multicast distribution for RTP video streaming between 1 and 255. TTL is a mechanism that limits the lifespan of data in a computer or network. It is implemented by having a counter or timestamp attached or embedded in the data in order to ensure that data is discarded once the correct time is reached. TTL counter decrements each time the signal pass through a router, so when the value reaches 0, the signal can no longer be distributed. For example, if TTL is set to [1], multicast distribution is confined to the local segment only and can not be distributed by the router.
- **Always Multicast this stream:** Check this box to start on-demand multicast RTP video stream without opening a new RTSP session.

Secondary Video Stream

Repeat Primary Video Stream setting steps for the Secondary Stream settings.

Audio Stream

Repeat Primary/Secondary Video Stream setting steps for the Audio Stream settings. However, notice that settings here are related to Audio, not video. **NOTE:** Audio stream configuration is synchronized to each video stream.

Restore Default Multicast Settings: Click this button to restore to the camera's default multicast settings.

Revert to previous Multicast Settings: Click this button to revert to the camera's previous multicast settings.

TCP/IP

Max. Transfer Unit (MTU): Set the value in the range 576 to 1500 for the largest packet size that can be sent through RTP streaming.

Restore Default TCP/IP Settings: Click this button to restore to the camera's default TCP/IP settings.

Revert to previous TCP/IP Settings: Click this button to revert to the camera's previous TCP/IP settings.

3.2.5.5 Pelco Smart Compression

The Pelco Smart Compression features the brilliantly efficient stream compression technology to not only economically exert leverage between different regions and compression levels, but also effectively reduce the average bit rate to level down the overall bandwidth exploitation. Refer to the following section for elaborate descriptions.

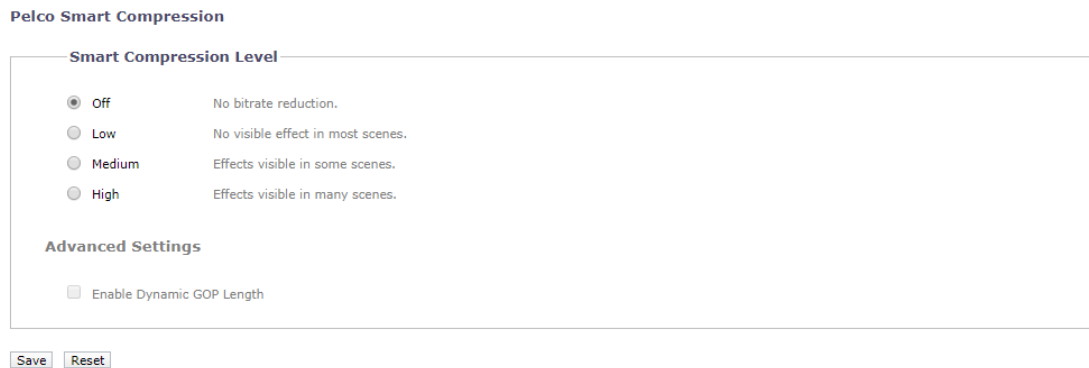

FIGURE 3-46: PELCO SMART COMPRESSION

Pelco Smart Compression Level

Pelco Smart Compression swiftly identifies dynamic motions occurred within a scene and retains its details with clear quality, whereas the other areas, e.g. static background, will be compressed to a higher compression level, thus economically decreasing bandwidth used on less important things and still keeping the dynamic motion details for future forensic purposes. The intensity for Pelco Smart Compression can be defined by the different level options. Selecting Off will simply disable this function.

Moreover, Pelco Smart Compression allows user to **enable Dynamic GOP Length**, which results in a significant bit rate reduction while keeping essentially the same video quality. Dynamic GOP achieves this feat by dynamically adjusting the interval between I-frames according to amount of motion in the scene. Hence, when in a scene there is limited or no motion; fewer I-frames will be used.

3.2.6 Events

Use the Events tab to configure camera events and analytics.

Events are activated by user-configured event sources that tell the device how to react when an event occurs. Event handlers are the actions that the device takes when an event occurs. For example, a system source can be configured to send email to an operator if a door contact switch is triggered. In order to configure events and event handlers, it is best to first configure the event source first and then configure the handler to trigger from that source.

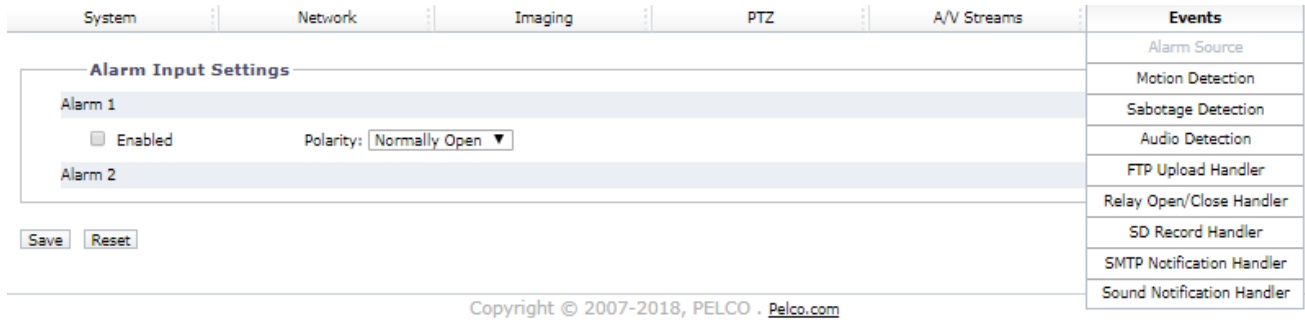

FIGURE 3-47: EVENTS SETTINGS

3.2.6.1 Alarm Source

The Alarm source is the camera input for an external signaling device, such as a door contact or motion detector. Both normally open and normally closed devices are supported. Spectra Pro supports two alarm inputs, each separately configurable.



FIGURE 3-48: ALARM SOURCE

Alarm Input Settings

1. Check **Enabled** button to enable **Alarm 1** and/or **Alarm 2**.
2. Select either **Normally Open** or **Normally Closed** from the Polarity drop-down menu.
 - **Normally Open:** An alarm will be triggered when the external contact closes.
 - **Normally Closed:** An alarm will be triggered when the external contact opens.
3. Click the Save button to save the settings, or click the Reset button to clear all of the information you entered without saving it.

3.2.6.2 Motion Detection

This function is designed to record video once the unit detects a motion.

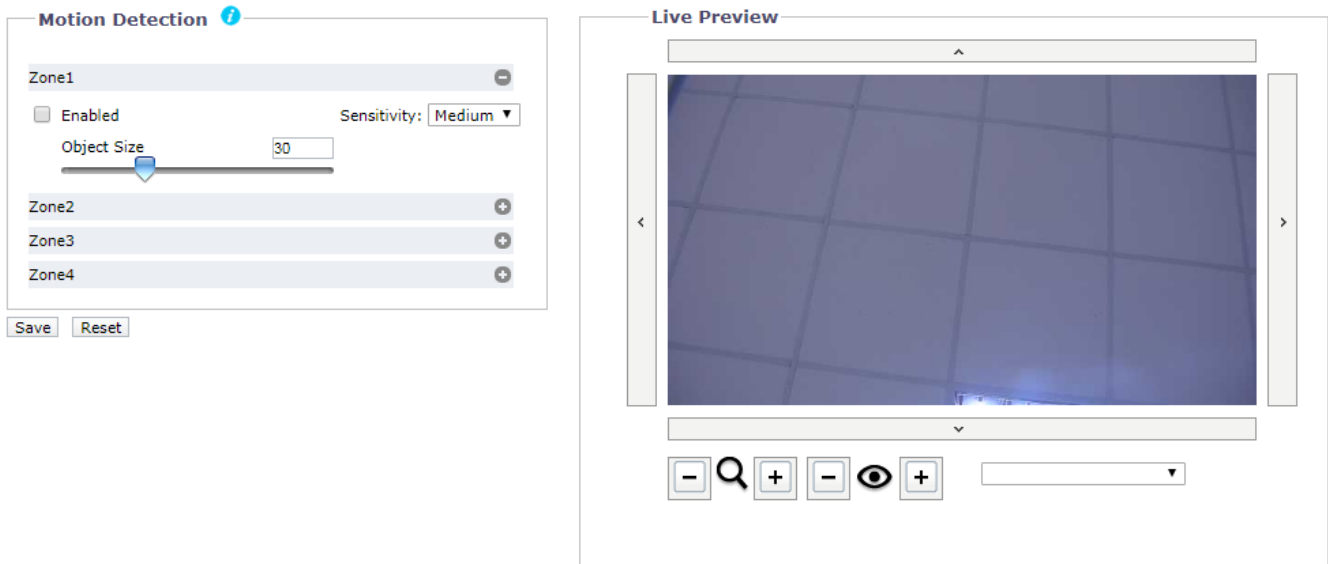

FIGURE 3-49: MOTION DETECTION SETTINGS

Motion Detection

1. Check the **Enabled** button to enable **Motion Detection**.
2. **Sensitivity:** Choose different levels of sensitivity from **High**, **Medium**, and **Low**.
 - **High:** Motion is activated with slight changes in brightness or motion.
 - **Low:** Motion is activated with big changes in brightness or motion.
3. Set the desired area to trigger motion detection. The motion setup screen will pop out a red rectangle for defining the detection area by dragging the mouse to resize it.

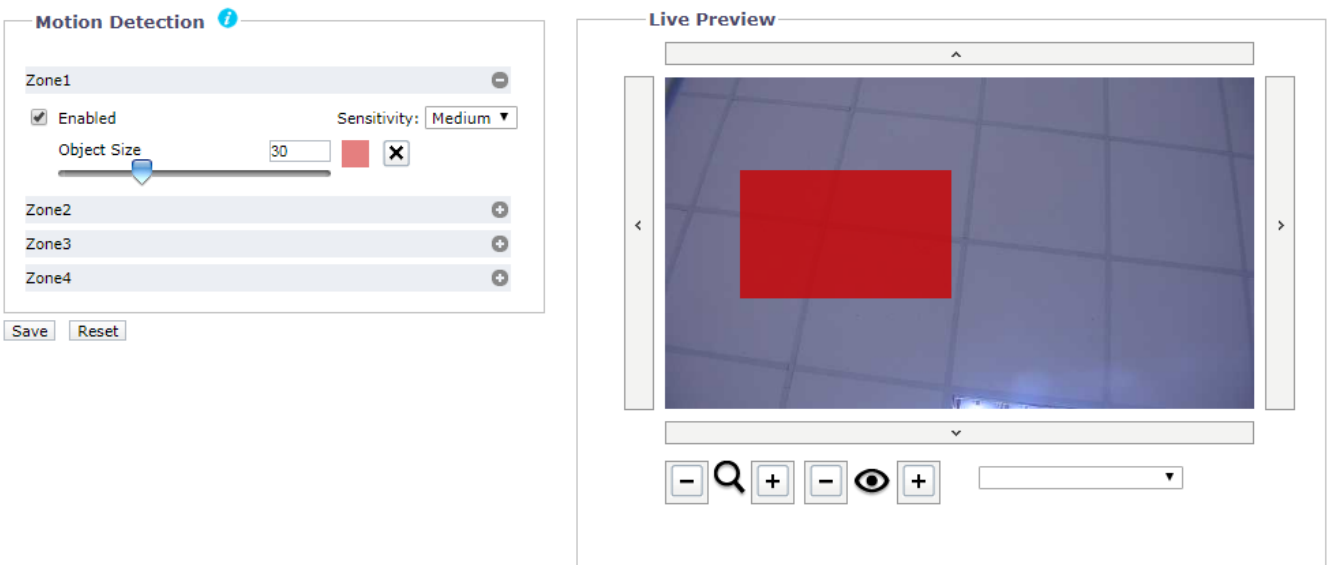

FIGURE 3-50: MOTION DETECTION ENABLED

4. Click the **Save** button to save the settings, or click the **Reset** button to clear all of the information you entered without saving it.

3.2.6.3 Sabotage Detection

The Camera Sabotage behavior detects scene changes or contrast changes in the field of view. An event or alarm is triggered if the lens is obstructed by spray paint, a cloth, or if it is covered with a lens cap. Any unauthorized repositioning of the camera also triggers an event or alarm.

Scene Setup for Camera Sabotage

Install the camera in a high position, looking down on the scene. The field of view should be as large as possible. A small field of view could result in the view being blocked by an adjacent object.

Avoid scenes with a dark, uniform background; low lighting; and large moving objects.

Sabotage Detection

1. Check the **Enabled** button to enable **Sabotage Detection**.
2. Configure the settings:
 - **Sensitivity:** Determines the triggering sensitivity for alarm. High sensitivity is triggered most easily and is prone to more false alarms. Low sensitivity will only trigger an alarm for major issues like blackout.
 - **Event logging (Profile) name:** Type a user-defined string name that will display within an alarm event to help users to easily distinguish among cameras.
 - **Alarm Severity:** Defines the severity of an alarm to allow the prioritization of alarms.

The screenshot shows a configuration window for 'Sabotage Detection'. It includes an 'Enabled' checkbox, a 'Sensitivity' dropdown menu currently set to 'Medium', an 'Event logging (Profile) name' text input field containing the text 'IP Camera-A301SO-30-T31552450', and an 'Alarm severity' dropdown menu with a list of options: 'Minor', 'Normal', 'Major', and 'Critical'. At the bottom left of the window are two buttons: 'Save' and 'Reset'.

FIGURE 3-51: SABOTAGE DETECTION

3. Click the Save button to save the settings, or click the Reset button to clear all of the information you entered without saving it.

3.2.6.4 Audio Detection

This function is designed to define the detailed settings for triggering surrounding audio detection. Check to enable this function. With an external mic connected, a waveform representing the level of audio will be displayed in the box.

Under **Sound Intensity Threshold**, adjust the threshold bar or input a number (from 0 to 100) in the box right above it for the desired threshold level. A horizontal line, which indicates the exact threshold, in the box underneath will move up or down accordingly.

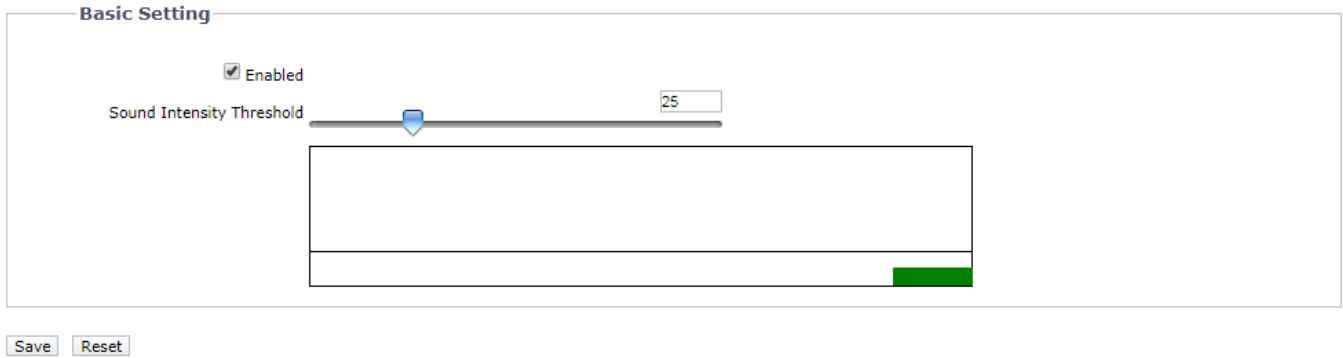

FIGURE 3-52: AUDIO DETECTION

3.2.6.5 FTP Upload Handler

Users can save image files via FTP by setting FTP recording condition beforehand.

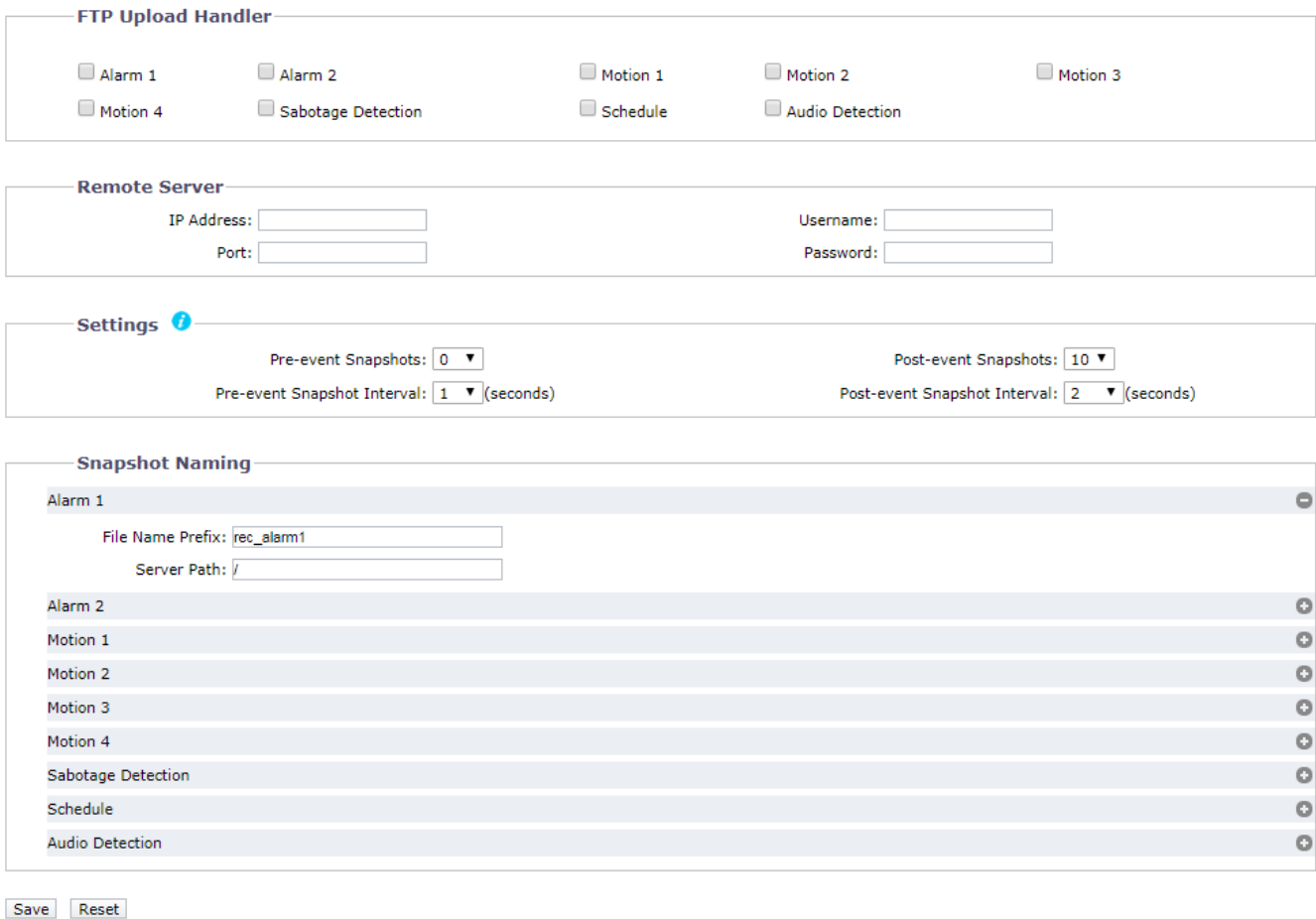

FIGURE 3-53: FTP UPLOAD HANDLER SETTINGS

FTP Upload Handler

You can store your image files based on the **Trigger** condition you have set.

- Alarm 1** through **Alarm 2**: Saves an image to a defined FTP server when the corresponding **Alarm** event is activated.

- **Motion 1** through **Motion 4**: Saves an image to a defined FTP server when motion is detected in one of the regions.
- **Sabotage Detection**: Saves an image to a defined FTP server when **Sabotage Detection** is activated.
- **Scheduled**: Saves an image to a defined FTP server when **Scheduled** event occurs.
- **Audio Detection**: Saves an image to a defined FTP server when **Audio Detection** is activated.

Remote Server

Remote Server is used as a service component to transfer files by simply entering the IP address or hostname with the Login ID and password.

1. **IP Address**: Input a server name or address.
2. **Port**: Set “21” as default or change to dedicated number.
3. **Username**: Input a user name with privilege to access the server.
4. **Password**: Input the password associated with Username.

NOTE: The default **Username** and **Password** are “guest” and “1234”.

Settings

1. Set **Pre-event Snapshots**, **Post-event Snapshots**, **Pre-event Snapshot Interval**, and **Post-event Snapshot Interval** for Alarm, Motion, Sabotage Detection, Schedule and Audio Detection.

Snapshot Naming

1. Set **File Name Prefix** and **Server Path** (where the data is to be stored on the server) for **Alarms**, **Motions**, **Sabotage Detection**, **Schedule**, and **Audio Detection**.

File Name Prefix:

Server Path:

FIGURE 3-54: SNAPSHOT NAMING ALARM / MOTION / SABOTAGE DETECTION / SCHEDULE / AUDIO DETECTION SETTINGS

2. Set **Trigger Interval** time and determine the recording condition: **OFF**, **All Day**, **Schedule 1**, or **Schedule 2** from scheduled table during 24/7 for **Schedule Settings**.

Schedule

Trigger Interval: (seconds)

Start: Start:

End: End:

Enter time values in 24-hour notation using the colon(:) character as a separator between hour and minutes, e.g: 8:00AM = 08:00, 4PM = 16:00

Day/Time Inclusion Filter	OFF	All Day	Scheduled 1	Scheduled 2
Monday	<input type="radio"/>	<input type="radio"/>	<input type="radio"/>	<input type="radio"/>
Tuesday	<input type="radio"/>	<input type="radio"/>	<input type="radio"/>	<input type="radio"/>
Wednesday	<input type="radio"/>	<input type="radio"/>	<input type="radio"/>	<input type="radio"/>
Thursday	<input type="radio"/>	<input type="radio"/>	<input type="radio"/>	<input type="radio"/>
Friday	<input type="radio"/>	<input type="radio"/>	<input type="radio"/>	<input type="radio"/>
Saturday	<input type="radio"/>	<input type="radio"/>	<input type="radio"/>	<input type="radio"/>
Sunday	<input type="radio"/>	<input type="radio"/>	<input type="radio"/>	<input type="radio"/>

File Name Prefix:

Server Path:

FIGURE 3-55: SNAPSHOT NAMING SCHEDULE SETTINGS

3. Click the **Save** button to save the settings, or click the **Reset** button to clear all of the information you entered without saving it.

3.2.6.6 Relay Open/Close Handler

Send a signal to an external device when an event is triggered.

The image shows two identical configuration panels for 'Relay Open/Close Handler1' and 'Relay Open/Close Handler2'. Each panel includes an 'Enabled' section with checkboxes for Alarm1, Alarm2, Motion1, Motion2, Motion3, Motion4, Sabotage Detection, and Audio Detection. Below this is a 'Polarity' dropdown menu set to 'Normally Open'. There are two sliders: 'On Time (Seconds)' and 'Off Time (Seconds)', both with numerical input fields set to 0.1. A 'Pulse Count' input field is set to 1. At the bottom of the entire configuration area are 'Save' and 'Reset' buttons.

FIGURE 3-56: RELAY OPEN/CLOSE HANDLER SETTINGS

Relay Open/Close Handler1/2

1. Select the **Alarm1** through **Alarm2**, **Motion1** through **Motion4**, **Sabotage Detection**, and **Audio Detection**.
2. **Polarity:** Set **Normally Open** to trigger a normally open external device and **Normally Close** to trigger a normally close device, when an event occurs.
3. Move the **On Time** slider to set the amount of time that the relay will remain open. The time range is 0.1 to 200 seconds; the default setting is 0.1.
4. Move the **Off Time** slider to set the amount of time that the relay will remain closed. The time range is 0.1 to 200 seconds; the default setting is 0.1.
5. **Pulse Count:** to set a count number for a cycle of relay handler, e.g., 6 counts means signals will be sent to external device 6 times.
6. Click the Save button to save the settings, or click the Reset button to clear all of the information you entered without saving it.

3.2.6.7 SD Record Handler

Save recorded video from different triggered events to a SD card which is inserted into a local camera already. Prior to initiating this function, a certified SD card must be properly installed.

NOTE: For the full compatibility between SD card and the camera, a 32 GB SanDisk Extreme® PLUS microSDHC™ UHS-I card is strongly recommended. Also, the SD card to be adopted must be a brand-new one without being used or reformatted previously to ensure the local storage feature correctly.

SD Record Handler

Alarm 1 Alarm 2 Motion 1 Motion 2 Motion 3
 Motion 4 Wire Network Lost Sabotage Detection Audio Detection

SD Record Settings

Record Type: Video only ▼
Record Status: One Shot ▼
Clip Duration: 5 (5~10 seconds)
Clip Size: 10 (10~20 MB)
Overwrite: On Off
Record Codec: H264 ▼

SD Information

Usage: 3%

Save Reset

FIGURE 3-57: SD RECORD HANDLER SETTINGS

1. Select **Alarm1** through **Alarm2**, **Motion1** through **Motion4**, **Wire Network Loss**, **Sabotage Detection** or **Audio detection**.
2. **Record Type:** Choose which record type to be adopted.
Audio And Video: Both video and audio will be recorded.
Video: Only video will be recorded.
3. **Record Status:** Define the method of recording.
One Shot: camera records video with designated duration and file size.
Continuous: camera keeps recording video continuously.
4. **Clip Duration:** 5 ~ 10 (sec)
Set the length limit for recording file.
5. **Clip Size:** 10 ~ 20 (MB)
Define the file size for recording file.
6. Set overwrite **ON** or **Off** to enable or disable the SD card to be **overwritten** automatically when the SD card is full of recordings.
7. **Record Coded:** Choose type of video codec, H.264 or H.265
8. **Usage:** Information of SD card usage.
9. Click the Save button to save the settings, or click the Reset button to clear all of the information you entered without saving it.

3.2.6.8 SMTP Notification Handler

Set SMTP Notification Handler function and send an email to a defined email address when an event is activated.

NOTE: To use email notification, the camera must be connected to a local area network (LAN) that maintains an SMTP mail server. Consult your network administrator for information on configuring email notification on your local network.

SMTP Notification Handler

Alarm 1 -

Enabled
 Attach JPEG Snapshot

Message:
From:

Subject:

Alarm 2 +

Motion1 +

Motion2 +

Motion3 +

Motion4 +

Sabotage Detection +

Audio Detection +

SMTP Server

Host Address:
Port:
Username:

Authentication: NO_AUTH
Password:

E-mail Address List

Enable	No.	Address	Alarm 1	Alarm 2	Motion1	Motion2	Motion3	Motion4	Sabotage	Audio
<input type="checkbox"/>	1	<input style="width: 150px;" type="text"/>	<input type="checkbox"/>	<input type="checkbox"/>	<input type="checkbox"/>	<input type="checkbox"/>	<input type="checkbox"/>	<input type="checkbox"/>	<input type="checkbox"/>	<input type="checkbox"/>
<input type="checkbox"/>	2	<input style="width: 150px;" type="text"/>	<input type="checkbox"/>	<input type="checkbox"/>	<input type="checkbox"/>	<input type="checkbox"/>	<input type="checkbox"/>	<input type="checkbox"/>	<input type="checkbox"/>	<input type="checkbox"/>
<input type="checkbox"/>	3	<input style="width: 150px;" type="text"/>	<input type="checkbox"/>	<input type="checkbox"/>	<input type="checkbox"/>	<input type="checkbox"/>	<input type="checkbox"/>	<input type="checkbox"/>	<input type="checkbox"/>	<input type="checkbox"/>
<input type="checkbox"/>	4	<input style="width: 150px;" type="text"/>	<input type="checkbox"/>	<input type="checkbox"/>	<input type="checkbox"/>	<input type="checkbox"/>	<input type="checkbox"/>	<input type="checkbox"/>	<input type="checkbox"/>	<input type="checkbox"/>
<input type="checkbox"/>	5	<input style="width: 150px;" type="text"/>	<input type="checkbox"/>	<input type="checkbox"/>	<input type="checkbox"/>	<input type="checkbox"/>	<input type="checkbox"/>	<input type="checkbox"/>	<input type="checkbox"/>	<input type="checkbox"/>
<input type="checkbox"/>	6	<input style="width: 150px;" type="text"/>	<input type="checkbox"/>	<input type="checkbox"/>	<input type="checkbox"/>	<input type="checkbox"/>	<input type="checkbox"/>	<input type="checkbox"/>	<input type="checkbox"/>	<input type="checkbox"/>
<input type="checkbox"/>	7	<input style="width: 150px;" type="text"/>	<input type="checkbox"/>	<input type="checkbox"/>	<input type="checkbox"/>	<input type="checkbox"/>	<input type="checkbox"/>	<input type="checkbox"/>	<input type="checkbox"/>	<input type="checkbox"/>
<input type="checkbox"/>	8	<input style="width: 150px;" type="text"/>	<input type="checkbox"/>	<input type="checkbox"/>	<input type="checkbox"/>	<input type="checkbox"/>	<input type="checkbox"/>	<input type="checkbox"/>	<input type="checkbox"/>	<input type="checkbox"/>
<input type="checkbox"/>	9	<input style="width: 150px;" type="text"/>	<input type="checkbox"/>	<input type="checkbox"/>	<input type="checkbox"/>	<input type="checkbox"/>	<input type="checkbox"/>	<input type="checkbox"/>	<input type="checkbox"/>	<input type="checkbox"/>
<input type="checkbox"/>	10	<input style="width: 150px;" type="text"/>	<input type="checkbox"/>	<input type="checkbox"/>	<input type="checkbox"/>	<input type="checkbox"/>	<input type="checkbox"/>	<input type="checkbox"/>	<input type="checkbox"/>	<input type="checkbox"/>

FIGURE 3-58: SMTP NOTIFICATION HANDLER SETTINGS

SMTP Upload Handler

1. Check **Enabled** button to enable **SMTP Upload Handler**.
2. Select the **Alarm 1** through **Alarm 2**, **Motion 1** through **Motion4**, **Sabotage Detection**, or **Audio Detection**.
3. Click in the text boxes (**Message**, **From**, and **Subject**), and then type the necessary information in each text box.
4. Select the **Attach JPEG Snapshot** box if you want to send a JPEG as an attachment.
5. Continue set the **SMTP Server** and **E-mail Address List**.

SMTP Server

Simple Mail Transfer Protocol (SMTP) is an Internet standard for electronic mail (e-mail) service across Internet Networking.

1. **Host Address:** Input a server name or address.
2. **Port:** set "25" as default or change to dedicated number.
3. **Username:** Input a user name with privilege to access the server.
4. **Password:** Input the password associated with Login ID.
5. **Authentication:** Select an authentication type.
 - **NO_AUTH:** Namely No Authentication, means no restriction.
 - **SMTP_PLAIN:** PLAIN is the name of a registered SASL authentication mechanism which serves as a parameter to the AUTH command. The PLAIN authentication mechanism is described in RFC 2595. PLAIN is the least secure of all the SASL authentication mechanisms since the password is sent unencrypted across the network.
 - **LOGIN:** The LOGIN mechanism is supported by Microsoft's Outlook Express as well as by some other clients.
 - **TLS_TTLS:** TLS is usually implemented on top of any of the Transport Layer protocols encapsulating the application-specific protocols such as HTTP, FTP, SMTP, NNTP and XMPP. The TLS protocol allows client-server applications to communicate across a network in a way designed to prevent eavesdropping and tampering. TLS can also be used to tunnel an entire network stack to create a VPN as is the case with OpenVPN.
6. Continue set the **E-mail Address List**.

E-mail Address List

This function is designed to notify multiple users via email when **Trigger** is set.

1. Check **Enable** and input the E-mail **Address** accordingly.
2. Select **Alarm**, **Motion** or **Sabotage** for sending E-mail.
3. Click the Save button to save the settings, or click the Reset button to clear all of the information you entered without saving it.

3.2.6.9 Sound Notification Handler

This page is designed for configuring detailed settings for sound notifications when an event occurs.

Sound Notification Handler

Level: Mid ▼

Alarm 1	<input type="checkbox"/>	Enable	Alarm sound: 1 ▼
Alarm 2	<input type="checkbox"/>	Enable	Alarm sound: 1 ▼
Motion 1	<input type="checkbox"/>	Enable	Alarm sound: 1 ▼
Motion 2	<input type="checkbox"/>	Enable	Alarm sound: 1 ▼
Motion 3	<input type="checkbox"/>	Enable	Alarm sound: 1 ▼
Motion 4	<input type="checkbox"/>	Enable	Alarm sound: 1 ▼
Sabotage Detection	<input type="checkbox"/>	Enable	Alarm sound: 1 ▼

Alarm sound settings

	File Status	Delete File	Select File (.wav) ?
1.	none	Delete	Browser
2.	none	Delete	Browser
3.	none	Delete	Browser
4.	none	Delete	Browser
5.	none	Delete	Browser
6.	none	Delete	Browser
7.	none	Delete	Browser
8.	none	Delete	Browser
9.	none	Delete	Browser
10.	none	Delete	Browser

Save Reset

FIGURE 3-59: SOUND NOTIFICATION HANDLER SETTINGS

Sound Notification Handler

1. Select the level ranging from **High**, **Mid** to **Low** of sound notification handlers for different events.
2. Check to enable **Alarm 1** through **Alarm 2**, **Motion 1** through **Motion 4**, or **Sabotage Detection**, and then select one of the ten alarm sounds from the dropdown menu designated for the different events enabled.
3. Continue to set the **Alarm Sound Settings**.

Alarm Sound Settings

1. Customize up to 10 sound files for each event alarm. Click on the **Browser** and locate a desired sound file, which should be specific 8kHz 16bit .wav format, from your computer to upload to the camera. The number will correspond to that under Alarm sound to be selected for the Motion or Sabotage Detection enabled.
2. In the vicinity of each number from the list, the status of the uploaded sound will be displayed under **File Status** (with “none” displayed when no file is uploaded) and the **Delete** button will be enabled. Click on **Delete** to delete the file if necessary.
3. Click the Save button to save the settings, or click the Reset button to clear all of the information you entered without saving it.

Pelco Troubleshooting Contact Information

If the instructions provided fail to solve your problem, contact Pelco Product Support at 1-800-289-9100 (USA and Canada) or +1-559-292-1981 (international) for assistance. Be sure to have the serial number available when calling. Do not try to repair the unit yourself. Leave maintenance and repairs to qualified technical personnel only.



This equipment contains electrical or electronic components that must be recycled properly to comply with Directive 2002/96/EC of the European Union -regarding the disposal of waste electrical and electronic equipment (WEEE). Contact your local dealer for procedures for recycling this equipment.

REVISION HISTORY

Manual #	Date	Comments
C2314M	09/18	Original version.
C2314M-A	01/19	Added 4K Series to the manual.
C2314M-B	03/19	Added Phase 2 Series to the manual.
C2314M-B	09/20	



Pelco

625 W. Alluvial Fresno, California 93711 United States
(800) 289-9100 USA & Canada Phone
(800) 289-9150 USA & Canada Fax
+1 (559) 292-1981 International Phone
+1 (559) 348-1120 International Fax
www.pelco.com

Pelco, the Pelco logo, and other trademarks associated with Pelco products referred to in this publication are trademarks of Pelco, Inc. or its affiliates. ONVIF and the ONVIF logos are trademarks of ONVIF Inc. All other product names and services are the property of their respective companies.

© Copyright 2020, Pelco, Inc.
All rights reserved.