

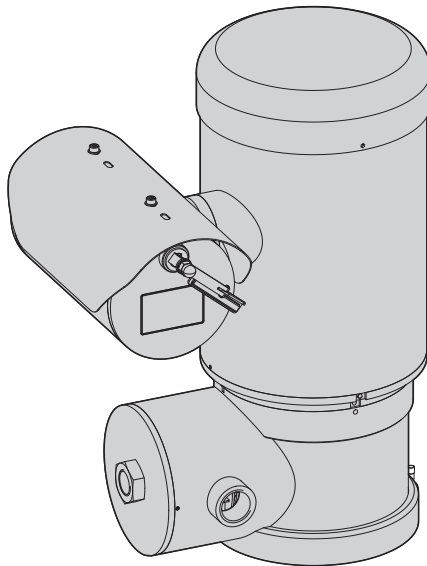

MAXIMUS MPX SERIES (MPXHD)

Explosion-proof PTZ camera



Contents

1 About this manual	5
1.1 Typographical conventions	5
2 Notes on copyright and information on trademarks	5
3 Safety rules	5
4 Identification	8
4.1 Product description and type designation	8
4.2 Range of use	8
4.3 Specific use conditions	8
4.4 Gas Group, Dust Group and Temperatures	8
4.5 Characteristics of installable devices	8
4.6 Cable entry	9
4.6.1 Stopping plug	9
4.7 Product marking	10
4.8 For UL/CSA standard reference only	11
5 Versions	13
5.1 Day/Night camera	13
6 Preparing the product for use	14
6.1 Unpacking	14
6.2 Contents	14
6.3 Safely disposing of packaging material	14
6.4 Preparatory work before installation	14
6.4.1 Methods of installation	14
6.4.2 Fixing to parapet or ceiling mount	15
6.4.3 Bracket mounting	15
6.4.4 Fastening with corner adaptor module or pole	16
6.4.5 Sunshield mounting	16
7 Installation	17
7.1 Ground connection	17
7.1.1 Earthing equipotential connection	17
7.1.2 Connection of the safety earthing	17
7.2 Opening of the connections compartment	17
7.3 Connector board description	18
7.4 Connection of the power supply line	18
7.5 Connecting alarms, remote reset and relays	19
7.5.1 Installations according to UL/CSA standards	20
7.5.2 Connecting an alarm with dry contact	21
7.5.3 Connecting the remote reset	21
7.5.4 Relays connection	21
7.6 Ethernet connection	21
7.6.1 Connection via RJ45	21
7.6.2 Connection via SFP	21
7.7 Connection compartment closing	22

8 Switching on	23
9 Configuration.....	23
9.1 Default IP address.....	23
9.2 Web interface.....	23
9.2.1 First access to the web pages.....	23
10 Instructions for normal operation	24
11 Maintenance	24
11.1 Routine maintenance.....	24
11.1.1 Inspecting the cables.....	24
11.1.2 Replacing the gasket.....	24
11.2 Extraordinary maintenance.....	25
11.2.1 Fuse replacement.....	25
11.2.2 Replacement of the wiper blade	25
11.2.3 Factory Default.....	25
12 Cleaning	26
12.1 Routine cleaning (to be performed on a periodic basis).....	26
12.1.1 Cleaning the glass window.....	26
12.1.2 Cleaning the product.....	26
13 Information on disposal and recycling	26
14 Troubleshooting	26
15 Technical data	27
15.1 General	27
15.2 Mechanical	27
15.3 Electrical	27
15.4 Network.....	27
15.5 I/O interface	27
15.6 Video.....	27
15.7 Day/Night cameras.....	28
15.8 Environment	28
15.9 Certifications.....	28
15.10 Certifications - Explosion-proof applications	28
16 Technical drawings	29

1 About this manual

Read all the documentation supplied carefully before installing and using this product. Keep the manual in a convenient place for future reference.

This document has been compiled and published using product descriptions and specifications available at the time of publication. The contents of this document and the specifications of the products discussed herein are subject to change without notice. Pelco Inc. reserves the right to make any such changes without notice. Neither Pelco Inc. nor any of its affiliated companies: (1) guarantees the completeness or accuracy of the information contained in this document; or (2) is responsible for your use of, or reliance on, the information. Pelco Inc. shall not be responsible for any losses or damages (including consequential damages) caused by reliance on the information presented herein.

For greater certainty, the use of "manufacturer" in this manual means "Videotec S.p.A."

1.1 Typographical conventions



DANGER!
Explosion hazard.
Read carefully to avoid danger of explosion.



DANGER!
High level hazard.
Risk of electric shock. Disconnect the power supply before proceeding with any operation, unless indicated otherwise.



CAUTION!
Medium level hazard.
This operation is very important for the system to function properly. Please read the procedure described very carefully and carry it out as instructed.



INFO
Description of system specifications.
We recommend reading this part carefully in order to understand the subsequent stages.

Underlined titles

Information is subject to certifications.

2 Notes on copyright and information on trademarks

The mentioned names of products or companies are trademarks or registered trademarks.

Pelco, the Pelco logo, and other trademarks associated with Pelco products referred to in this publication are trademarks of Pelco, Inc. or its affiliates.

ONVIF® is a trademark of Onvif, Inc.

Other names or logos mentioned herein may be the trademarks of their respective owners.

The absence of the symbols ™ and ® in proximity to each trademark in this document or at all is not a disclaimer of ownership of the related trademark.

Covered by one or more claims of the patents listed at patentlist.hevcadvance.com.

3 Safety rules



DANGER!
Explosion hazard.
Read carefully to avoid danger of explosion.

- Installation and maintenance of the appliance must be carried out by specialist technical staff in compliance with the applicable reference standard EN/IEC 60079-14, EN/IEC 60079-17 and national standards.
- Do not open the device when powered and in explosive atmosphere.
- Use appropriate tools for the installation. The particular nature of the site where the device is to be installed may mean special tools are required for installation.
- Make all connections, installation and maintenance work in a non-explosive atmosphere.

- The equipotential connection is mandatory to avoid the risk of ignition of products installed in potentially explosive environments.
- This device must be connected to an earth conductor (protective earth). This connection must only be performed through the power line connector. External equipotential bonding connections must also be performed but only for supplementary bonding connection to earth, and required by local codes or authority.
- Before powering the product in an explosive atmosphere, ensure the cover is closed correctly.
- The temperature of the surfaces of the device is increased by exposure to direct sunlight. The surface temperature class of the device was determined only with ambient ambient temperature, without taking into consideration direct sunlight.
- Make sure that all the equipment are certified for the application and for the environment in which they will be installed.
- Any change that is not expressly approved by the manufacturer will invalidate the guarantee.
- The electrical system to which the unit is connected must be equipped with a 16A max automatic bipolar circuit breaker. The minimum distance between the circuit breaker contacts must be 3mm (0.1 in). The circuit breaker must be provided with protection against the fault current towards the ground (differential) and the overcurrent (magnetothermal).
- The device can only be considered to be switched off when the power supply has been disconnected and the connection cables to other devices have been removed.
- Be careful not to use cables that seem worn or old.
- All the cables must comply with IEC60332-1-2, IEC 60332-1-3 and IEC/EN60079-14.
- When commencing installation make sure that the specifications for the power supply for the installation correspond with those required by the device.
- For continued protection against risk of fire, replace only with same type and rating of fuse. Fuses must be replaced only by service personnel.
- This equipment is not suitable for use in locations where children are likely to be present.

**DANGER!****High level hazard.**

Risk of electric shock. Disconnect the power supply before proceeding with any operation, unless indicated otherwise.

- Make sure that the power is off when installing or carrying out maintenance, with the circuit-breaker open.
- A power disconnect device must be included in the electrical installation, and it must be very quickly recognizable and operated if needed.

**CAUTION!****Medium level hazard.**

This operation is very important for the system to function properly. Please read the procedure described very carefully and carry it out as instructed.

- Make sure that the installation complies with local regulations and specifications.
- Make connections and tests in the laboratory before carrying out installation on site.
- Check that the power supply socket and cable are adequately dimensioned.
- Use suitable cables that can withstand the operating temperatures.

- All disconnected cables must be electrically isolated.
- The system can be installed only in a standard or inverted position (ceiling mount).
- Make sure the product is to be secured to building before operation.
- At start up the system makes some automatic calibration movements: do not stand near the device when it is powered.
- The manufacturer declines all liability for damage to any of the apparatus mentioned in this handbook, when resulting from tampering, use of non-original spare parts, installation, maintenance and repairs performed by non-authorized, non-skilled personnel.
- For technical services, consult only and exclusively authorized technicians.
- This product must only be repaired by suitably trained personnel or under the supervision of VIDEOTEC personnel in accordance with the foreseen terms and conditions: IEC/EN60079-19.
- Only use original VIDEOTEC spare parts. Strictly adhere to the maintenance instructions attached to each replacement kit.
- The equipment is intended for installation in a Restricted Access Area by specialist technical staff.
- The manufacturer declines all responsibility for any damage caused by an improper use of the appliances mentioned in this manual. Furthermore, the manufacturer reserves the right to modify its contents without any prior notice. The documentation contained in this manual has been collected and verified with great care. The manufacturer, however, cannot take any liability for its use. The same thing can be said for any person or company involved in the creation and production of this manual.
- Since the user is responsible for choosing the surface to which the unit is to be anchored, we do not supply the fixing devices for attaching the unit firmly to the particular surface. The installer is responsible for choosing fixing devices suitable for the specific purpose on hand. Use methods and materials capable of supporting at least 4 times the weight of the device.
- Contact the manufacturer for information on the dimensions of the flameproof joint.
- For all maintenance interventions, we recommend you return the product to the laboratory that will perform all required operations.
- This device is remotely controlled and may change position at any time. It should be installed so that no one can be hit by moving parts. It should be installed so that moving parts cannot hit other objects and create hazardous situations.
- This is a Class A product. In a domestic environment this product may cause radio interference. In this case the user may be required to take adequate measures.
- To comply with the main supply voltage dips and short interruption requirements, use a suitable Uninterruptable Power Supply (UPS) to power the unit.



INFO

**Description of system specifications.
We recommend reading this part carefully
in order to understand the subsequent
stages.**

- Given the considerable weight of the system, use an appropriate transport and handling system. The staff must carry out the handling of the product in compliance with the common accident prevention standards.
- Before proceeding with installation, check the supplied material to make sure it corresponds to the order specification by examining the identification labels.

4 Identification

4.1 Product description and type designation

The MAXIMUS MPX series is a range of electropolished AISI316L steel PTZ cameras that can be installed in potentially explosive environments.

The MAXIMUS MPX series is equipped with a NPT or metric cables entry according to the model.

The MAXIMUS MPX series has an IP66/IP68/IP69 degree of protection and can be installed in environments with temperatures from -40°C to +80°C (check the marking for each model available).

Versions are available with visible light camera, thermal camera, or dual vision with visible light and thermal camera.

4.2 Range of use

The unit is designed for use in a fixed location, for surveillance of areas classified as zone 1-21 and zone 2-22 with potentially explosive atmospheres.

The unit has been built and certified in compliance with directive 2014/34/UE and with the international standards IECEx, which define its range of application and minimum safety requirements.

4.3 Specific use conditions

Contact the manufacturer for information on the dimensions of the explosion proof joint.

Ambient temperature and Surface temperature – see instructions.

Care shall be taken to prevent accumulation of electrostatic charges. See installation instructions.

The unit can be only installed in standard or inverted position.

4.4 Gas Group, Dust Group and Temperatures

The device is certified for the IIC group (Gas) and the IIIC group (dust).

The temperature class, the maximum surface temperature and the temperature of the cables entry depend on the characteristics of the installable devices (dissipated power, Watt) and the ambient temperature.

The features are specified for each model in its specific chapters.

4.5 Characteristics of installable devices

All the internal components must be installed inside by the manufacturer.

4.6 Cable entry

The product is supplied with plastic caps for cable entry protection. They cannot be used for installation.

Unused cable entries must be closed using appropriate Ex certified locking devices with "db" and "tb" explosion protection, suitable for the use conditions and installed correctly.

All cable glands shall be Ex certified, as appropriate, with protection type "db" and "tb", suitable for the conditions of use and installed correctly.

When conduit is used, a suitable Ex certified stopping box shall be used, as appropriate, with protection type "db" and "tb", suitable for the conditions of use and installed correctly.

The stopping box must be fitted within 50mm (1.97in) from the enclosure entry.

The cable entry temperatures are specified in the marking.

To maintain the IP level of product use cable glands with appropriate IP level and apply to threads a sealant compliant with standard IEC/EN60079-14.

4.6.1 Stopping plug



The stopping plug supplied is not KCs certified.

With the product, an Ex certified stopping plug is supplied with "db" and "tb" explosion-proof type protection. Thread sealant is also supplied, in compliance with IEC/EN60079-14, the use ensure the IP degree.

The stopping plug installation instructions are available on <https://peppers.co.uk/useful-documents/>.

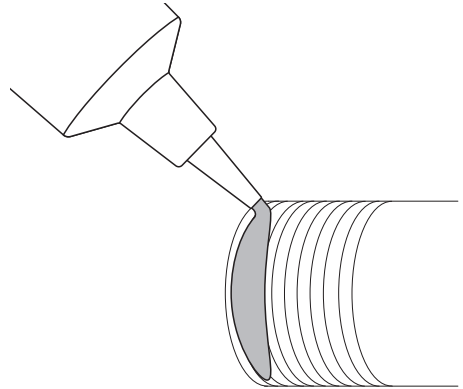

Fig. 1

4.7 Product marking

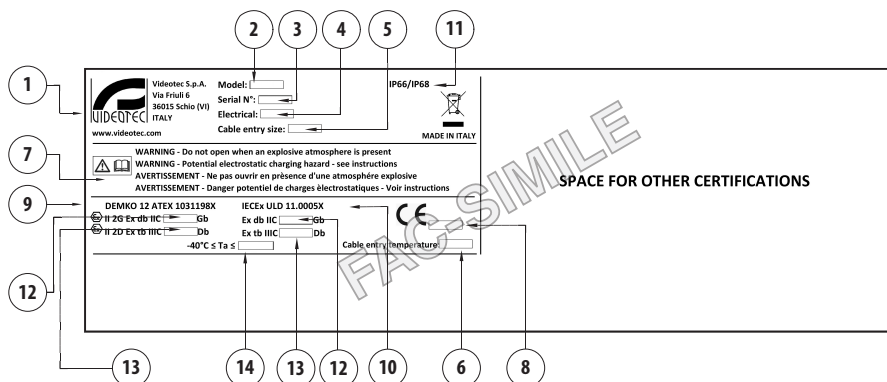

Fig. 1

1. Manufacturer's name and address.
2. Model.
3. The serial number consists in 12 numeric characters, the second and third digits define the last two numbers of the year of manufacture.
4. Electrical characteristics (voltage V, frequency Hz, current A, power W).
5. Number, dimension and type of cable entries.
6. Cable entry temperature.
7. Warnings.
8. The number of the accredited body that provides the quality assessment.
9. ATEX marking. The Class temperature depends on the electronics installed inside and the ambient temperature.
10. Marking IECEx. The Class temperature depends on the electronics installed inside and the ambient temperature.
11. IP protection degree.
12. T Class (Tx or Tx...Tx).
13. Maximum surface temperature (Tx°C or Tx°C...Tx°C).
14. Ambient temperature ($-40^{\circ}\text{C} \leq T_a \leq +T_x^{\circ}\text{C}$, $-40^{\circ}\text{C} \leq T_a \leq T_x^{\circ}\text{C}$ or $T_x^{\circ}\text{C}$ or $T_x^{\circ}\text{C}$ or $T_x^{\circ}\text{C}$).

Example of marking:

EXAMPLE DATA				
Dissipated power in housing (W)	T Class	Maximum surface temperature	Cable entry temperature	Ambient temperature
7	T4	T135°C	90°C	$-40^{\circ}\text{C} \leq T_a \leq 80^{\circ}\text{C}$
	T6...T5	T85°C...T100°C	80°C	$-40^{\circ}\text{C} \leq T_a \leq 60^{\circ}\text{C}$ or 70°C
	T6...T4	T85°C...T135°C	90°C	$-40^{\circ}\text{C} \leq T_a \leq 60^{\circ}\text{C}$ or 70°C or 80°C

Tab. 1

4.8 For UL/CSA standard reference only.



The flameproof joints are not intended to be repaired.



CAUTION! Hazardous moving parts. Keep fingers and other body parts away.



The appliance includes moving parts. Make sure that the unit is positioned where it is inaccessible under normal operating conditions. Attach the warning label supplied with the appliance, placing it near the unit so that it can be seen easily.



Fig. 2



In the USA, the National Electrical Code (NEC) and in Canada the Canadian Electrical Code (CEC) apply to electrical equipment used on hazardous industrial premises.

Important safety instructions

WARNING: DO NOT OPEN WHEN AN EXPLOSIVE ATMOSPHERE IS PRESENT.

AVERTISSEMENT: NE PAS OUVRIR EN PRÉSENCE D'UNE ATMOSPHÈRE EXPLOSIVE.

WARNING: POTENTIAL ELECTROSTATIC CHARGING HAZARD - SEE INSTRUCTIONS.

AVERTISSEMENT: DANGER POTENTIEL DE CHARGES ÉLECTROSTATIQUES - VOIR INSTRUCTIONS.

WARNING: CONDUITS MUST BE SEALED WITHIN 50MM OF CONDUIT ENTRANCE TO THE ENCLOSURE.

AVERTISSEMENT: LES CONDUITS DOIVENT ÊTRE SCELLES À DANS 50MM DE L'ENTRÉE DU CONDUIT DU CAISSON.

In installations according to UL/CSA standards, installation is compulsory of the separator provided as indicated in the relevant chapter (7.5.1 Installations according to UL/CSA standards, page 20).

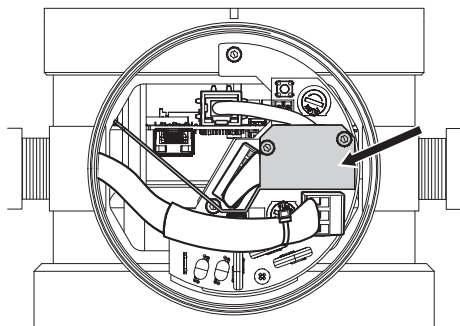

Fig. 3

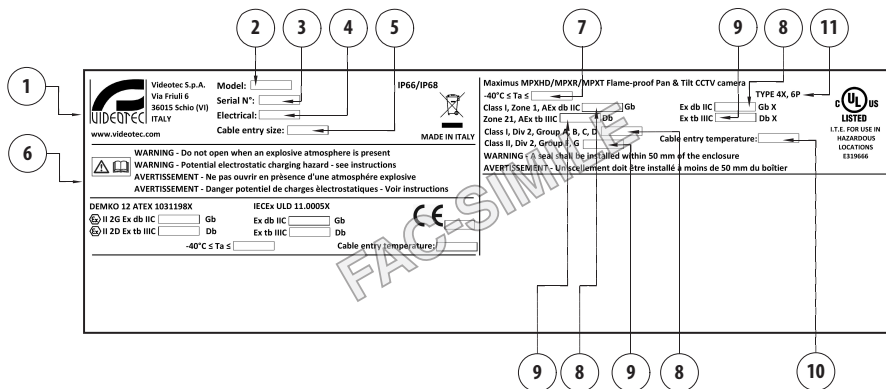

Fig. 4

1. Manufacturer's name and address.
2. Model.
3. The serial number consists in 12 numeric characters, the second and third digits define the last two numbers of the year of manufacture.
4. Electrical characteristics (voltage V, frequency Hz, current A, power W).
5. Number, dimension and type of cable entries.
6. Warnings.
7. Ambient temperature ($-40^{\circ}\text{C} \leq T_a \leq +T_x^{\circ}\text{C}$, $-40^{\circ}\text{C} \leq T_a \leq T_x^{\circ}\text{C}$ or $T_x^{\circ}\text{C}$, $-40^{\circ}\text{C} \leq T_a \leq T_x^{\circ}\text{C}$ or $T_x^{\circ}\text{C}$ or $T_x^{\circ}\text{C}$).
8. T Class (T_x or $T_x...T_x$).
9. Maximum surface temperature ($T_x^{\circ}\text{C}$ or $T_x^{\circ}\text{C}...T_x^{\circ}\text{C}$).
10. Cable entry temperature.
11. Level of protection Type.

Connections



The choice of connection must comply with local legislation in force.

Cable glands: select a cable gland in compliance with UL2225 with the following protection AEx db IIC and/or AEx tb IIC and C22.2 with the following protection Ex db IIC and/or Ex tb IIC in compliance with the marking of the product.

Conduit: it is necessary to install a sealing device within 50mm of the product input when the conduit is used.

Regulation references:

UL 60079-0, 7th Edition, Explosive Atmospheres - Part 0: Equipment – General requirements

UL 60079-1, 7th Edition, Explosive Atmospheres - Part 1: Equipment Protection by Flameproof Enclosures "d"

UL 60079-31, 2nd Edition, Explosive Atmospheres - Part 31: Equipment Dust Ignition Protection by Enclosure "t"

CSA C22.2 No. 60079-0:19, Explosive Atmospheres - Part 0: Equipment - General requirements

CSA C22.2 No. 60079-1:16, Explosive Atmospheres - Part 1: Equipment Protection by Flameproof Enclosures "d"

CSA C22.2 No. 60079-31:15, Explosive Atmospheres - Part 31: Equipment Dust Ignition Protection by Enclosure "t"

5 Versions

5.1 Day/Night camera

MAXIMUS MPX SERIES2 - CONFIGURATION OPTIONS						
	Voltage	Camera	Temperature class and ambient temperature			
MPXHD	1 230Vac	5 Pelco® Day/Night 30X zoom, Full HD camera	E T6...T5 -40°C/+55°C or +70°C	0	0	C
	2 24Vac					
	3 120Vac					

Tab. 2

MAXIMUS MPX SERIES2 - CERTIFICATIONS AND MARKINGS				
Part number	Certification	Marking	Ambient temperature	Cable entry temperature
MPXHD*5E0**C	ATEX	⊕ II 2 G Ex db IIC T6...T5 Gb ⊕ II 2D Ex tb IIIC T85°C...T100°C Db	-40°C ≤ Ta ≤ +55°C or +70°C	80°C
	IECEX	Ex db IIC T6...T5 Gb Ex tb IIIC T85°C...T100°C Db		
	EAC Ex	1Ex d IIC T6...T5 Gb X Ex tb IIIC T85°C...T100°C Db X		
	INMETRO	Ex db IIC T6...T5 Gb Ex tb IIIC T85°C...T100°C Db		
	KCs	Ex d IIC T6...T5 Ex tb IIIC T85°C...T100°C		
	Hazardous Location America	Class I, Zone 1, AEx db IIC T6...T5 Gb Zone 21, AEx tb IIIC T85°C...T100°C Db Class I, Div 2, Group A, B, C, D T6...T5 Class II, Div 2, Group F and G T6...T5		
	Hazardous Location Canada	Ex db IIC T6...T5 Gb X Ex tb IIIC T85°C...T100°C Db X Class I, Div 2, Group A, B, C, D T6...T5 Class II, Div 2, Group F and G T6...T5		

Tab. 3

6 Preparing the product for use



Before carrying out any type of intervention, read the "Safety rules" chapter carefully in the product manual.

6.1 Unpacking

When the product is delivered, make sure that the package is intact and that there are no signs that it has been dropped or scratched.

If there are obvious signs of damage, contact the supplier immediately.

When returning a faulty product we recommend using the original packaging for shipping.

Keep the packaging in case you need to send the product for repairs.

6.2 Contents

Check the contents to make sure they correspond with the list of materials as below:

- Explosion-proof PTZ camera
- Sunshield
- Silicone sheath
- O-ring replacement part kit, hexagon socket set screws
- Stopping plug
- Sealant
- Cable ties
- Separation barrier for installations according to UL/CSA standards
- Instruction manual

6.3 Safely disposing of packaging material

The packaging material can all be recycled. The installer technician will be responsible for separating the material for disposal, and in any case for compliance with the legislation in force where the device is to be used.

6.4 Preparatory work before installation

It is possible to install the unit with several brackets.

We strongly recommend using only approved brackets and accessories during installation.

6.4.1 Methods of installation

The system can be installed only in a standard or inverted position (ceiling mount). When installed for inverted operation, the camera orientation and controller functions are reconfigured for normal operation through the system's software.

Hardware adjustment is not required for inverted operation.

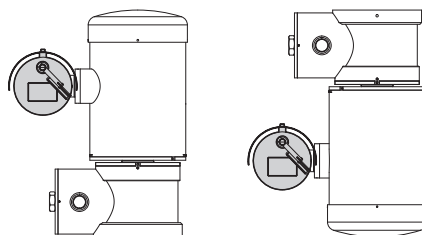

Fig. 5

6.4.2 Fixing to parapet or ceiling mount

Fix the adaptor (01) to the bottom of the unit using the 4 flat countersunk screws (02) with hexagonal socket M10x20mm in stainless steel (A4 class 70) supplied.

Make sure the thread are free of dirt and debris.

Apply a generous amount of thread locking compound (Loctite 270) into the threaded holes in the base of the device.

Pay attention to the fixing. Tightening torque: 35Nm.

The thread compound must cure for one hour, allow for this period prior to completing the installation.

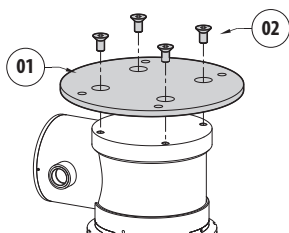

Fig. 6

Use the external holes in the adaptor to fix the assembled unit to the parapet or to the ceiling. Use screws that can bear at least 4 times the weight of the unit.

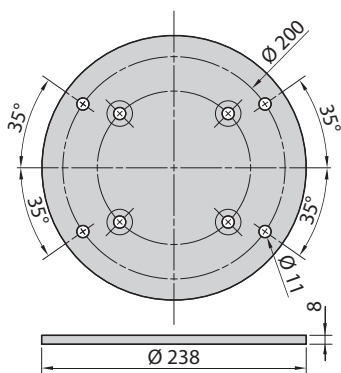

Fig. 7

6.4.3 Bracket mounting

The bracket can be fixed to the vertical wall. Use screws and wall fixing devices that can bear at least four times the weight of the unit.

Then, fix the device to the bracket using the 4 flat washers, the 4 spring washers in stainless steel and the 4 hexagonal head screws in stainless steel (A4 class 70) supplied (M10x20mm).

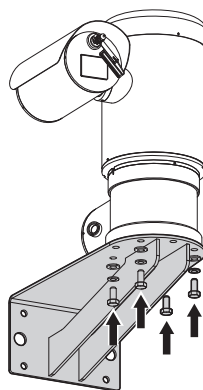

Fig. 8

Make sure the thread are free of dirt and debris.

Apply a generous amount of thread locking compound (Loctite 270) on the 4 screws.

Tighten the screws.

Pay attention to the fixing. Tightening torque: 35Nm.

The thread compound must cure for one hour, allow for this period prior to completing the installation.

6.4.4 Fastening with corner adaptor module or pole

To install the product on the corner adaptor module or pole, first of all fasten the support bracket.

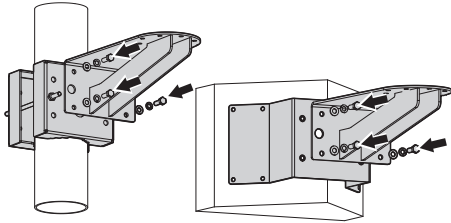

Fig. 9

To fasten the support bracket, use the 4 flat washers, the 4 elastic washers in stainless steel and the 4 hexagonal head screws in stainless steel (A4 class 70) M10x30mm supplied.

Make sure the thread are free of dirt and debris.

Apply a generous amount of threadlocker (Loctite 270) on the 4 threaded holes on the adaptor module.

Tighten the screws.



Pay attention to the fixing. Tightening torque: 35Nm.

The thread compound must cure for one hour, allow for this period prior to completing the installation.

To fix the device to the bracket, consult the relevant chapter (6.4.3 Bracket mounting, page 15).

6.4.5 Sunshield mounting



Remove the protective film before the sunshield installation (if present).

Fix the sunshield to the housing using the screws and washers screwed into the upper body of the housing.

Apply a generous amount of thread locking compound (Loctite 270) into the threaded holes in the base of the device.

The thread compound must cure for one hour, allow for this period prior to completing the installation.

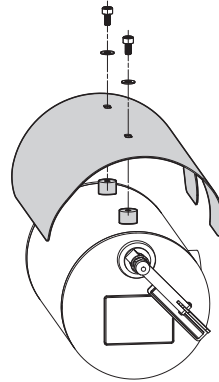

Fig. 10



Pay attention to the fixing. Tightening torque: 2Nm.

7 Installation

⚠ Before carrying out any type of intervention, read the "Safety rules" chapter carefully in the product manual.

VIDEOTEC strongly recommend to test the device configuration and performance before putting it in the final installation site.

7.1 Ground connection

7.1.1 Earthing equipotential connection

The equipotential connection must be carried out using an external cable with a minimum 4mm² section (11AWG).

Connect the cable for the earthing equipotential connection with the eyelet terminal supplied (suitable for cables with 4mm²(11AWG) up to 6mm²(9AWG) section).

Fasten the eyelet using the M5 screw and lock washer supplied.

Characteristics of the M5 screw:

- Material: A4 Class 70
- Screw head: ISO 4762
- Length: 8mm (0.3in)

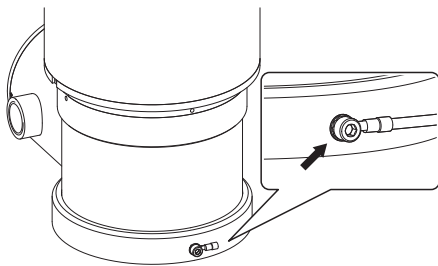

Fig. 11

7.1.2 Connection of the safety earthing

The earth wire must be connected to the internal connector (J1, 7.3 Connector board description, page 18).

7.2 Opening of the connections compartment

i The safety grub screw is used to prevent the unscrewing of the threaded cover from the connection compartment. Remove the security grub screw before unscrewing the threaded cover.

The bottom of the unit has no.2 3/4" NPT cable entries (or M25 special version).

To install the connections, remove the safety grub screw (01) using a male 1.5mm hex key, the threaded cover (02) (30mm hex nut) and the plastic plugs (03).

The plastic plugs are only used for shipping purposes and should not be used during operation.

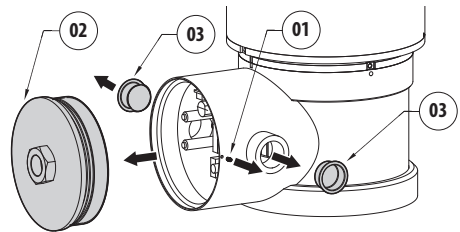

Fig. 12

By unscrewing the threaded lid, the connectors are accessed.

7.3 Connector board description

BOARD DESCRIPTION		
Connector	Function	Terminals - Nominal section of the cables used
J1	Power supply line	from 0.2mm ² (24AWG) up to 2.5mm ² (13AWG)
J6	Alarms, Remote reset and serial line	from 0.2mm ² (24AWG) up to 1.0mm ² (17AWG)
J8	Relay	from 0.2mm ² (24AWG) up to 1.0mm ² (17AWG)
F1	Fuse	-
F2	Fuse	-
P1	Reset push-button	-
RJ45	Ethernet Connector	-
SFP	SFP connector	-

Tab. 4

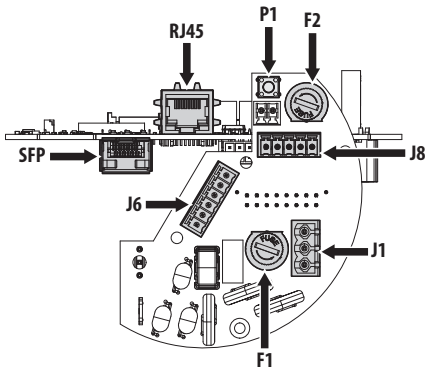

Fig. 13

7.4 Connection of the power supply line

Depending on the version, the device can be provided with different power supply voltages. The power supply voltage is indicated on the product identification label.



Earth cable should be about 10mm longer than the other two, so that it will not be disconnected accidentally if pulled.



The power supply cable must be covered by the silicone sheath (01) supplied. The silicone sheath must be fastened with the corresponding cable tie (02). For installations according to UL/CSA standards, pass the power supply cable through the cables input on the left (03), as indicated in the figure.



If using the VIDEOTEC multipolar cable and a fibre optic cable, you are advised to use the left cables input (03) for the multipolar cable and the right cables input (04) for the fibre optic.

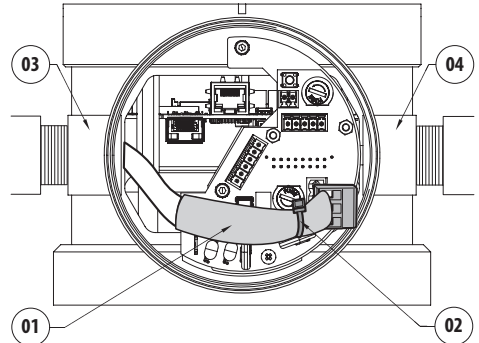

Fig. 14



The ground conductor should be equal or greater in section than the section of the power supply cables.

Extract the removable power line connector from the connector board (J1, 7.3 Connector board description, page 18).

Connect the electrical power cables as indicated in the relevant table (Tab. 5, page 19).

7.5 Connecting alarms, remote reset and relays



All signal cables must be grouped together by means of a cable tie.

CONNECTION OF THE ALARM INPUTS AND RELAYS		
Con-nectors	Terminals	Description
J6	AL1, COM	Self-powered alarm input fitted in the common terminal
	RST, RST	Remote reset
J8	RL1A, RL1B	Clean output contacts, can be activated by alarm or by user control
	RL2A, RL2B	Contact for washer pump activation

Tab. 6

CONNECTION OF THE POWER SUPPLY LINE	
Colour	Terminals
Power supply 24Vac	
Defined by the installer	N (Neutral)
Defined by the installer	L (Phase)
Yellow/Green	⊕
Power supply 230Vac	
Blue	N (Neutral)
Brown	L (Phase)
Yellow/Green	⊕
Power supply 120Vac	
Blue	N (Neutral)
Brown	L (Phase)
Yellow/Green	⊕

Tab. 5

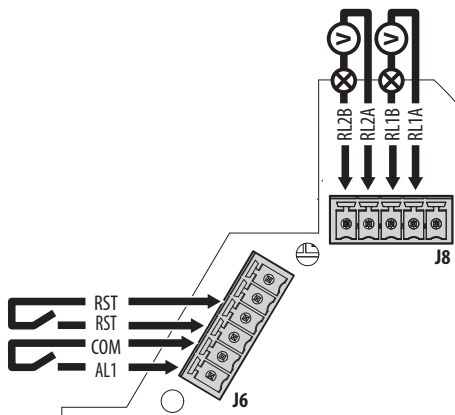

Fig. 15

7.5.1 Installations according to UL/CSA standards



Pay attention not to damage the conductors and the boards.

For installations according to UL/CSA standards, the cables for Ethernet, reset alarms, relays and fibre optics should be inserted in the right cables entry as indicated in the following figure (Fig. 16, page 20).

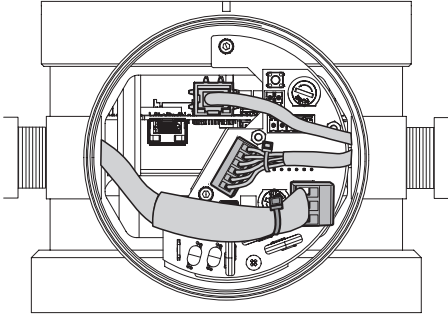

Fig. 16

In installations according to UL/CSA standards, installation is compulsory of the separation barrier provided.

Having inserted all the connectors and before powering the device, install the separation barrier supplied.

Fasten the barrier (01) using the specific screws and washers (02) to the prepared spacers (03) (Fig. 17, page 20 and Fig. 18, page 20).

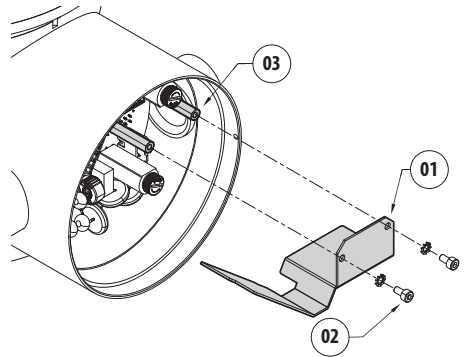

Fig. 17

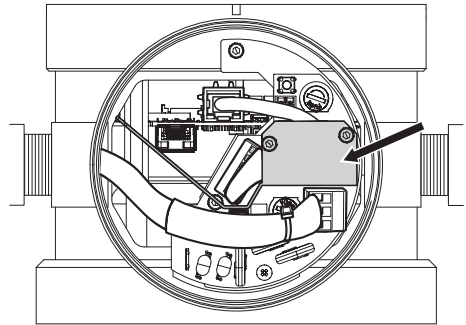

Fig. 18

7.5.2 Connecting an alarm with dry contact

Connect terminals AL1 and COM to connector J6 as shown in the image (Fig. 15, page 19).

Maximum length of the alarm cables: 200m (656ft).

Use a shielded cable to carry out the connection.

7.5.3 Connecting the remote reset

Connect the two RST terminals on connector J6 as illustrated in the figure (Fig. 15, page 19).

Maximum cable length: 200m (656ft).

Read the Factory Default chapter to find out how to use the remote reset (11.2.3 Factory Default, page 25).

7.5.4 Relays connection

i **Maximum relay voltage and current: read the technical data in the relevant chapter (15 Technical data, page 27).**

Connect terminals RL1A, RL1B, RL2A, RL2B to connector J8 as shown in the image (Fig. 15, page 19).

The device can be equipped with a washing system. Use the terminals RL2A and RL2B to control the wash system.

7.6 Ethernet connection

The product is equipped with an integrated Ethernet switch that manages a RJ45 port and a slot for SFP modules.

7.6.1 Connection via RJ45

i **Make connections in accordance with the TIA/EIA-568-B standard.**

Connect the Ethernet cable to port RJ45 (7.3 Connector board description, page 18).

Use of Ethernet cables with the following characteristics is highly recommended:

- STP (isolated)
- Category 5E or category 6

Use a shielded RJ45 connector on both ends of the cable. The Ethernet cable shield (user side) must always be earthed via the connector.

7.6.2 Connection via SFP

i **The optical modules compliant with the SFP (Small Form Factor Pluggable) standard are conversion devices of the electrical to optical signal and the optical to electrical signal.**

The SFP module is used for the optical fiber connection. The SFP module should be suitable for the installation system.

Consult the SFP module manual for the relevant specifications.

! **The SFP module (not supplied by VIDEOTEC) must meet the following requirements:**

- Laser: Class 1, complies with EN60825-1
- UL/IEC 60950-1 or UL/IEC 62368-1 Certification

i **The user switch, connected via the SFP module, must work at a speed of 100Mbps. Check the settings of the switch to which the product is connected.**

i **VIDEOTEC has tested various types of SFP modules. For further information please contact the VIDEOTEC service center.**

Insert the SFP module (not supplied) in the SFP slot (7.3 Connector board description, page 18).

7.7 Connection compartment closing



If you can't turn by hand the threaded lid before the OR reaches the tube of the connection compartment this means that there are debris/dirt on the threads or that the lid is misaligned. In this case there's a serious danger of threads damaging. Unscrew the lid and check the alignment and/or clean the threads.



Never force the rotation of threaded lid before the OR reaches the connection compartment, otherwise thread damage could occur.



If you suspect that any kind of thread damaging has occurred, suspend the installation. The device could be no longer safe for the installation on a potentially explosive atmosphere. In this case contact VIDEOTEC technical support.



Before closing the cover, check the O-ring gasket is intact. If the gasket is damaged, replace it with the one supplied (11.1.2 Replacing the gasket, page 24).

Verify that there is no dirt or debris.

Lubricate the threads with grease compliant with IEC/ EN60079-14 to facilitate screwing the cover on.

Arrange the cables so that there is no interference when closing the threaded lid of the connection compartment.

Screw by hand the threaded lid of the connection compartment till the OR gasket reaches the tube.

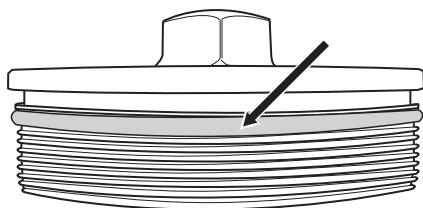

Fig. 19

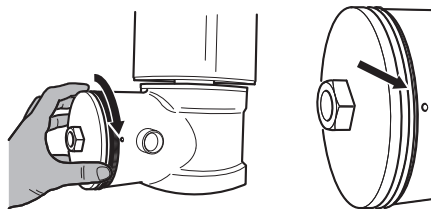

Fig. 20

Use a 30mm wrench for closing the threaded lid of the connection compartment. Make sure that there's no gap between the threaded cap and the junction box tube after tightening the cap.

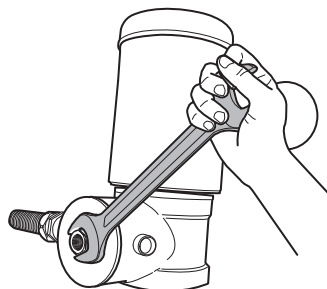

Fig. 21

Fixing the safety grub screw is necessary to complete product closure, to prevent unwanted unscrewing of the threaded plug.

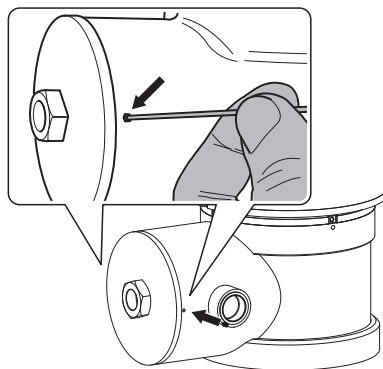



Fig. 22

8 Switching on

 Before carrying out any type of intervention, read the "Safety rules" chapter carefully in the product manual.

 **The automatic pre-heating (De-Ice) process could be started whenever the device is switched on and the ambient temperature is below 0°C (+32°F). The procedure is necessary to guarantee correct operation of the devices even at low temperatures. The duration ranges depending on environmental conditions (from 60 minutes up to 120 minutes).**

The unit is switched on by connecting the power supply.

It takes a few minutes for the unit to become fully operational after it is switched on.

To switch off the unit disconnect the power.

9 Configuration

9.1 Default IP address

 **The unit is configured to obtain an IP address from a DHCP server.**

The IP address acquired via DHCP is visible in the DHCP server log file.

If the DHCP server is not available, the unit automatically configures itself with a self-generated IP address in the 169.254.x.x/16 subnet. Configuring the IP address of the PC as belonging to the same subnet (example: IP address: 169.254.1.1, subnet mask: 255.255.0.0).

Use an ONVIF compliant VMS or the Motorola Solutions Camera Configuration Tool to find the IP address of the device.

9.2 Web interface

 **Browsers supported (the latest version): Microsoft Edge, Google Chrome™, Mozilla Firefox.**

9.2.1 First access to the web pages

The first operation in configuring the device consists in connecting to the web interface.

To access the web interface of the product, simply use a browser to connect to `http://ip_address`.

On first access, the Home page will be displayed.

Additional information about setting up and using the device is available in: www.pelco.com/exsite-enhanced-2

10 Instructions for normal operation



Before carrying out any type of intervention, read the "Safety rules" chapter carefully in the product manual.



Do not use the wiper if the ambient temperature is under 0°C or if there is ice.



If it is left on, the wiper automatically disables itself.

The device control can be performed through different modes:

- Through the user's controls of the web interface (9.2 Web interface, page 23).
- Through Video Management Software (VMS) that supports the ONVIF protocol. In this case the special controls are implemented using the auxiliary commands of the ONVIF protocol.

11 Maintenance



Before carrying out any type of intervention, read the "Safety rules" chapter carefully in the product manual.

When contacting VIDEOTEC for assistance please provide the serial number and the identification code of the model.

Use only VIDEOTEC original spare parts.

11.1 Routine maintenance

11.1.1 Inspecting the cables

The cables should not show signs of damage or wear, which could generate hazardous situations. In this case extraordinary maintenance is necessary.

11.1.2 Replacing the gasket

Replace the connection compartment cover seal using the one supplied.

Open and close the connection compartment as described in the previous chapters.

Replace the gasket, paying attention to position it correctly.

11.2 Extraordinary maintenance

11.2.1 Fuse replacement

If necessary, replace the fuses illustrated in figure (7.3 Connector board description, page 18).

FUSES REPLACEMENT		
Supply voltage	Fuse (F1)	Fuse (F2)
24Vac, 50/60Hz	T 4A H 250V 5x20	T 4A H 250V 5x20
120Vac, 50/60Hz	T 2A H 250V 5x20	T 4A H 250V 5x20
230Vac, 50/60Hz	T 2A H 250V 5x20	T 4A H 250V 5x20

Tab. 7

11.2.2 Replacement of the wiper blade

In models equipped with a wiper, the worn blades can be replaced.

Unscrew the rivet nut fastening the blade and remove it with the washers. Replace the worn blade with a new one. Apply a good quantity of threadlocker (Loctite 270), reposition the rivet nut and the washers by adjusting fastening until the blade correctly tits to the glass. Activate the wiper to check the blade is correctly adjusted.

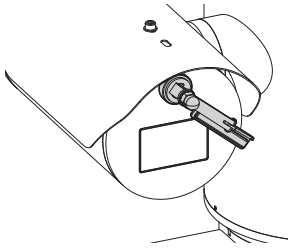

Fig. 23

11.2.3 Factory Default



If the access password is no longer available, follow the procedure to reset to default factory settings.

To restore the factory settings relative to the network, user access and camera configuration follow this procedure:

- Switch off the unit.
- Open the connection compartment.
- Press and hold the reset button (P1, 7.3 Connector board description, page 18).
- Power the unit.
- Wait 30 seconds.
- Release the reset button.
- Wait for 3 minutes.
- Switch off the unit.
- Close the connections compartment.
- Power the unit.

It is also possible to perform the reset in remote mode. Follow the procedure below:

- Switch off the unit.
- Connect the RST contacts of connector J6 (7.3 Connector board description, page 18).
- Power the unit.
- Wait 30 seconds.
- Disconnect the RST contacts.
- Wait for 3 minutes.
- Switch off the unit.
- Power the unit.



Once the factory default procedure has terminated, you need to configure the unit as described in the relevant chapter (9.1 Default IP address, page 23).

12 Cleaning

 **Before carrying out any type of intervention, read the "Safety rules" chapter carefully in the product manual.**

 **Frequency will depend on the type of environment in which the product is used.**

12.1 Routine cleaning (to be performed on a periodic basis)

12.1.1 Cleaning the glass window

Cleaning should be done with mild soap diluted with water.

12.1.2 Cleaning the product

 **The cleaning of the product should be carried out according to the instructions in this chapter in order to prevent accumulation of electrostatic charges.**

 **The outside surface of the product must never be covered in more than 5 mm of dust.**

The device should be cleaned using a damp cloth; compressed air must not be used.

13 Information on disposal and recycling

The European Directive 2012/19/EU on Waste Electrical and Electronic Equipment (WEEE) mandates that these devices should not be disposed of in the normal flow of municipal solid waste, but they should be collected separately in order to optimize the recovery stream and recycling of the materials that they contain and to reduce the impact on human health and the environment due to the presence of potentially hazardous substances.

 **The symbol of the crossed out bin is marked on all products to remember this.**

The waste may be delivered to appropriate collection centers, or may be delivered free of charge to the distributor where you purchased the equipment at the time of purchase of a new equivalent or without obligation to a new purchase for equipment with size smaller than 25cm (9.8in).

For more information on proper disposal of these devices, you can contact the responsible public service.

14 Troubleshooting

 **Before carrying out any type of intervention, read the "Safety rules" chapter carefully in the product manual.**

 **Contact an authorized support centre if the problems listed below persist or you have any other issues that are not described here.**

PROBLEM	The product does not go on.
CAUSE	Wiring error, blown fuse.
SOLUTION	Make sure the connections are correct. Check the continuity of the fuses and replace them with the indicated models should they fail.
PROBLEM	The shooting area do not correspond to the selected preset position.
CAUSE	Loss of absolute position reference point.
SOLUTION	Reset the equipment by switching off and on again.
PROBLEM	The device does not move during the start-up phase.
CAUSE	The ambient temperature is too low.
SOLUTION	Wait until the end of the pre-heating procedure. The following message is displayed on the web page: De-Ice procedure in progress.

15 Technical data

15.1 General

AlSi 316L stainless steel construction

External surfaces micro-shot peened and electro-polished

Dynamic positioning control system

15.2 Mechanical

Cable inputs: 2 x 3/4" NPT

Zero backlash

Horizontal rotation: 360°, continuous rotation

Vertical rotation: from -90° up to +90°

Horizontal speed (variable): from 0.1° to 100°/s

Tilt speed (variable): from 0.1° to 100°/s

Accuracy of preset positions: 0.02°

Integrated wiper

Window with extra clear tempered glass: thick 12mm (0.47in)

Unit weight: 26.5kg (58lb)

15.3 Electrical

Supply voltage/Current consumption:

- 230Vac ±10%, 0.5A, 50/60Hz
- 24Vac ±10%, 5A, 50/60Hz
- 120Vac ±10%, 1A, 50/60Hz

Power consumption:

- 120W max

15.4 Network

RJ45 port

- Ethernet connection: 10BASE-T/100BASE-T

Slot SFP (SMALL FORM FACTOR PLUGGABLE)

- Ethernet connection: 100BASE-FX
- Supply voltage: 3.3V
- Standard: MSA compliant

The SFP module (not supplied by VIDEOTEC) must meet the following requirements:

- Laser: Class 1, complies with EN60825-1
- Certification: UL/IEC 60950-1 or UL/IEC 62368-1

15.5 I/O interface

Input for remote reset: 1

Alarm inputs: 1

Relay outputs: 1+1 (1A, 30Vac/60Vdc max, one relay reserved for washer pump and one configurable)

15.6 Video

Video encoder

- Communication protocol: ONVIF, Profile G, Profile S and Profile T
- Protocols: IPv4, IPv6, HTTP, HTTPS, SOAP, DNS, NTP, RTSP, RTCP, RTP, TCP, UDP, IGMP, ICMP, DHCP, Zeroconf, ARP
- Streaming Protocols: RTP/UDP, RTP/UDP multicast, RTP/RTSP/TCP, RTP/RTSP/HTTP/TCP, RTP/RTSP/HTTPS/TCP, HTTP
- Video compression: H.264, H.265, Motion JPEG
- Streaming: Multi-stream H.264, Multi-stream H.265, Motion JPEG
- Motion Detection:

Pixel motion: Selectable sensitivity and threshold

Classified object detection

- Security: Password protection, HTTPS encryption, digest authentication, WS authentication, user access log, 802.1x port based authentication
- Device Management Protocols: SNMP v2c, SNMP v3

15.7 Day/Night cameras

Resolution: Full HD 1080p (1920x1080pixel)

Image Sensor: 1/2.8" Progressive Scan CMOS

Focal length: from 4.3mm (wide) up to 129mm (tele)

Zoom: 30x

Max Aperture: F1.6

Horizontal Angle of View Based on Aspect Ratio:(16:9)
2.3°-66°

Electronic Shutter Control: Automatic, Manual

White balance: Automatic, Manual

Wide Dynamic Range: 120dB

Exposure Control: Automatic, Manual, Priority (Iris Priority, Shutter Priority), Brightness, Custom

De-fog: On/Off

Privacy Zones: Yes

Day/Night Control: Automatic, Manual

Flicker Control: 60Hz, 50Hz

Backlight Compensation: On/Off

15.8 Environment

For indoors and outdoors installation

Operating temperature:

- Continuous functioning: from -40°C (-40°F) up to +55°C (131°F), in enclosed space; from -40°C (-40°F) up to +60°C (140°F) with ambient convection
- De-icing function intervention (cold start): from -40°C (-40°F) up to -10°C (14°F)

Wind resistance

- PTZ static: 230km/h (143mph) max.
- PTZ operational at the maximum speed: 210km/h (130.5mph) max.

Relative humidity: from 5% up to 95%

15.9 Certifications

Electrical safety (CE): EN60950-1, IEC60950-1, EN62368-1, IEC62368-1

Electromagnetic compatibility (CE): EN50130-4, EN55032 (Class A), EN61000-6-4, EN61000-3-2, EN61000-3-3

RoHS (CE): EN50581

Outdoor installation (CE): EN60950-22, IEC60950-22

Vibration test: EN50130-5, EN60068-2-6

UL certification (UL60950-1, CAN/CSA C22.2 No. 60950-1-07, UL62368-1, CAN/CSA C22.2 No. 62368-1-14): cULus Listed

Electromagnetic compatibility (North America): FCC part 15 (Class A), ICES-003 (Class A)

IP protection degree (EN/IEC60529): IP66, IP67, IP68, IP69

Level of protection Type (UL50E): 4X, 6P

RCM (Australian and New Zealand Regulatory Compliance Mark)

15.10 Certifications - Explosion-proof applications

ATEX (EN IEC 60079-0, EN 60079-1, EN 60079-31)

IECEX (IEC 60079-0, IEC 60079-1, IEC 60079-31)

UL listed for USA (UL 60079-0, UL 60079-1, UL 60079-31)

UL listed for Canada (CAN/CSA-C22.2 NO. 60079-0, CAN/CSA-C22.2 NO. 60079-1, CAN/CSA-C22.2 NO. 60079-31)

EAC Ex (TR CU 012/2011)

INMETRO (ABNT NBR IEC 60079-0, ABNT NBR IEC 60079-1, ABNT NBR IEC 60079-31)

16 Technical drawings

i The indicated measurements are expressed in millimetres.

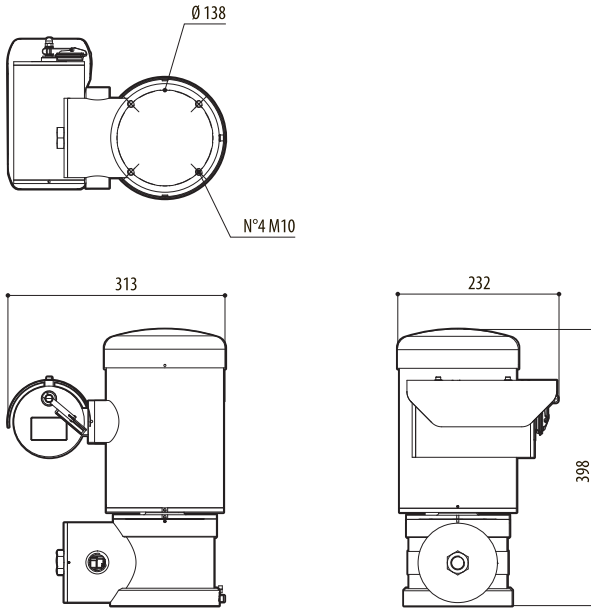

Fig. 24 MAXIMUS MPX SERIES2.



Headquarters Italy Videotec S.p.A.
Via Friuli, 6 - I-36015 Schio (VI) - Italy
Tel. +39 0445 697411 - Fax +39 0445 697414
Email: info@videotec.com
www.videotec.com