



UNITI POWER SYMPHONY

SPY1500RMi2U & SPY3000RMi2U USER MANUAL

A RACKMOUNTABLE UNINTERRUPTIBLE POWER
SUPPLY PROVIDING UNITY POWER AND TRUE
ONLINE DOUBLE CONVERSION

Please visit www.unitipower.com for assistance

Download the app



THE UNITI POWER SYMPHONY 1500VA – 3000VA

SAFETY INSTRUCTIONS

KEEP THESE INSTRUCTIONS IN A SAFE PLACE

This manual contains important instructions that should be followed during the installation and maintenance of the UPS and batteries.

UPS models operate at an optimal temperature of 20-25C

CERTIFICATION STANDARDS

- Safety: IEC/EN 62040-1
- EMC: IEC/EN 62040-2
- Performance: IEC/EN 62040-3
- ISO 9001:2015
- ISO: 14001:2015

SPECIAL SYMBOLS



RISK OF ELECTRIC SHOCK – observe the warning associated with the risk of electric shock symbol



Important instructions that must always be followed



EU separate collection and lead content mark for lead-acid batteries. This indicates that the battery must not be disposed of with the 'normal' household waste but separately collected and recycled



EU separate collection mark for waste electrical and electronic equipment (WEEE). This indicates that the item must not be disposed of with the 'normal' household waste but separately collected and recycled



Information, advice, help



Refer to the user manual

SAFETY OF PERSONS

- Dangerous voltage levels are present within the system. It should only be opened by qualified service personnel.
- The system must be properly grounded
- The battery supplied with the system contains small amounts of toxic materials. To avoid accidents, the instructions listed below must be observed:
 - Servicing of batteries should be performed by personnel knowledgeable about batteries and the required precautions
 - When replacing batteries, replace with the same type and number of batteries or battery packs
 - **CAUTION:** Do not dispose of the batteries in a fire. The batteries may explode. Dispose of used batteries according to the instructions
 - Do not open or damage the batteries. Released electrolyte is harmful to the skin/eyes and may be toxic
 - **CAUTION:** A battery can present a risk of electric shock and high short circuit current. The following precautions should be observed when working on batteries:
 - Remove watches, rings, or other metal objects
 - Use tools with insulated handles
 - Wear rubber gloves and boots
 - Do not lay tools or metal parts on top of batteries
 - Disconnect the charging source before connecting or disconnecting battery terminals
 - Determine if the battery is inadvertently grounded. If inadvertently grounded, remove the source from the ground. Contact with any part of a grounded battery can result in electrical shock. The likelihood of such shock can be reduced if such ground are removed during installation and maintenance
 - Failed batteries can reach temperatures that exceed the burn thresholds for touchable surfaces

PRODUCT SAFETY

- The UPS connection instructions and operation described in the manual must be followed in the indicated order
- UPS enclosure IP rating IP20
- **CAUTION:** To reduce the risk of fire, the unit connects only to a circuit provided with a branch circuit overcurrent protection of 20A rating, The upstream circuit breaker must be easily accessible
- For PERMANENTLY CONNECTED EQUIPMENT, a readily accessible disconnect device shall be incorporated externally into the equipment
- For PLUGGABLE EQUIPMENT, the socket outlet shall be installed near the equipment and shall be easily accessible
- Check that the indications on the rating plate correspond to your AC powered system and to the actual electrical consumption of all the equipment to be connected to the system
- Never install the system near liquids or in an excessively damp environment
- Never let a foreign body penetrate the system
- Never block the ventilation grates of the system
- Never expose the system to direct sunlight or source of heat
- If the system must be stored before installation, storage must be in a dry place
- The admissible storage temperature range is -25C to +55C without batteries, 0C to +40C with batteries – it is advised that the batteries are stored below 25C
- This UPS can be used in TN/IT/TT power systems

SPECIAL PRECAUTIONS

- The unit is heavy: wear safety shoes and suitable lifting equipment
- All handling operations will require at least two people (unpacking, lifting, installation in rack system)
- Before and after the installation, if the UPS remains de-energised for a long period, the UPS must be energised for a period of 24 hours, at least once every 6 months (for a normal storage temperature of less than 25C). This charges the battery, thus avoiding possible irreversible damage
- During the replacement of the battery module, it is imperative to use the same type and number of elements as the original battery module provided with the UPS to maintain an identical level of performance and safety.

 This is a category C2 UPS product. In a residential environment, this product may cause radio interference, in which case the user may be required to take additional measures.

Contents

SAFETY INSTRUCTIONS	2
CERTIFICATION STANDARDS	2
SPECIAL SYMBOLS	2
SAFETY OF PERSONS	3
PRODUCT SAFETY.....	4
SPECIAL PRECAUTIONS	4
1. INTRODUCTION	7
1.1 ELECTRONIC EQUIPMENT PROTECTION.....	7
1.2 ENVIRONMENTAL PROTECTION.....	7
2. PRODUCT OVERVIEW	8
2.1 WEIGHT AND DIMENSIONS.....	8
2.2 REAR PANELS.....	9
3. INSTALLATION	10
3.1 INSPECTING THE EQUIPMENT	10
3.2 CHECKING THE ACCESSORY KIT	10
3.3 INSTALLATION (UPS)	11
3.3.1 RT MODELS.....	12
3.4 CONNECTING THE EBM(S).....	13
4. OPERATION	14
4.1 LCD PANEL.....	14
4.2 LCD DESCRIPTION.....	15
4.3 DISPLAY FUNCTIONS	17
4.4 USER SETTINGS	17
4.5 STARTING THE UPS WITH UTILITY POWER	18
4.6 STARTING THE UPS ON BATTERY.....	19
4.7 UPS SHUTDOWN	19
5. COMMUNICATION	20
5.1 RS232 AND USB.....	20
5.2 UPS REMOTE CONTROL FUNCTIONS.....	20
5.3 IOT.....	21
5.4 MODBUS TCP	22
5.5 INTELLIGENT CARDS (OPTIONAL).....	22
5.6 UPS MANAGEMENT SOFTWARE	22
5.6.1 WINPOWER.....	22
5.6.2 WinPower View App	23
6. UPS MAINTENANCE	24
6.1 EQUIPMENT CARE	24
6.2 TRANSPORTING THE UPS	24
6.3 STORING THE EQUIPMENT	24
6.4 REPLACING BATTERIES	24
6.5 RECYCLE	24
7. TROUBLESHOOTING	25
8. SPECIFICATIONS	26

8.1 UPS BLOCK DIAGRAM..... 26

8.2 UPS SPECIFICATION..... 27

1. INTRODUCTION

Thank you for selecting UNITI to protect your electrical equipment.

We recommend that you take the time to read this manual and take full advantage of the many features of the UPS (uninterruptible power supply).

Before installing the UPS, please read the safety instructions. Then follow the indications in this manual.

1.1 ELECTRONIC EQUIPMENT PROTECTION

The UPS protects your sensitive equipment from the most common power problems including power failures, power sags, power surges, brownouts, line noise, high voltage spikes, frequency variations, switching transients, and harmonic distortion.

Special characteristics:

- Online double conversion with pure sine waveform output
- Full digital control
- Higher power density and unity output power factor
- Wider input voltage range: 110Vac-300Vac
- Higher efficiency: 93% for 3Kva, 89% for 1Kva
- Input THDI<5%
- Higher charger current for long backup mode: 8A adjustable from 2A to 8A through LCD screen
- Intelligent EBM quantity detection
- Communication ports: EPO, Dry in, Dry out, intelligent slot, USB, RS232
- IoT: Ethernet (default) and wireless (Optional)
- Dot-matrix LCD supports multi-language
- ECO mode
- Startable without battery

1.2 ENVIRONMENTAL PROTECTION

Products are developed according to an eco-design approach

Substances

This product does not contain CFCs, HCFCs or asbestos

Packing

To improve waste treatment and facilitate recycling, separate the various packing components.

- The cardboard we use comprises over 50% of recycled cardboard
- Sacks and bags are made of polyethene
- Packing materials are recyclable

Follow all local regulations for the disposal of packing materials

Battery

The product contains lead-acid batteries that must be processed according to applicable local regulations concerning batteries.

The battery may be removed to comply with regulations and in view of correct disposal.

2. PRODUCT OVERVIEW

2.1 WEIGHT AND DIMENSIONS



The weights in this table is for reference only, please see the labels on the carton for details

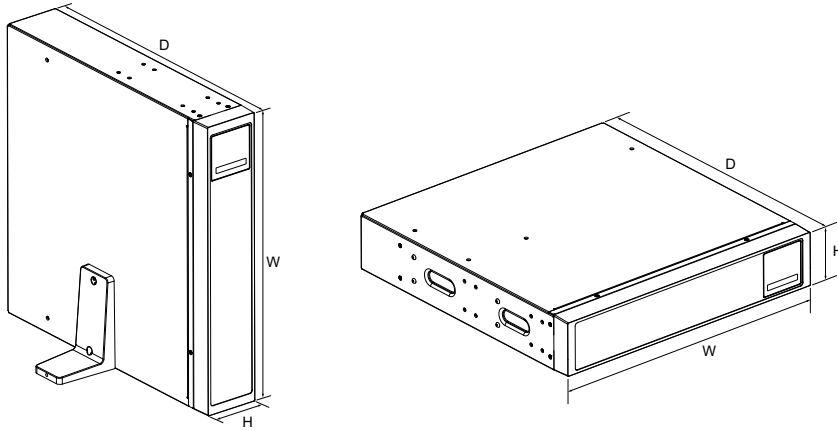

Description	Net Weights (KG)	Dimensions: D x W x H (mm)
SPY1500RMi2U	15.8	445 x 438 x 85.5
SPY3000RMi2U	26.2	600 x 438 x 85.5
EBM3618RT2U	22.6	445 x 438 x 85.5
EBM7218RT2U	39.9	600 x 438 x 85.5

2.2 REAR PANELS

SPY1500RMi2U

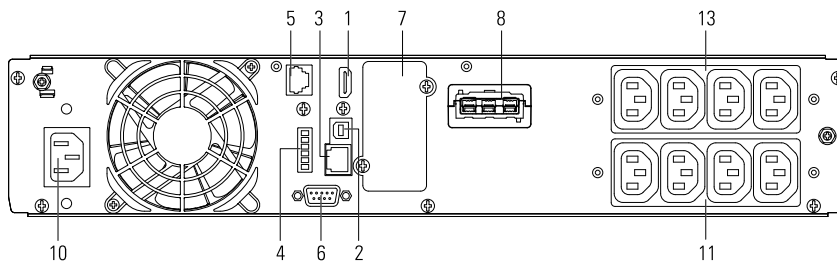

SPY3000RMi2U

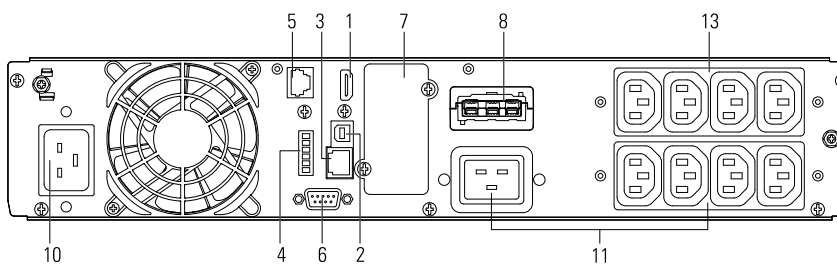

EBM3618RT2U

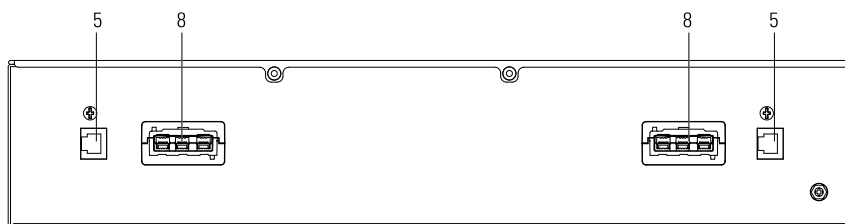

EBM7718RT2U

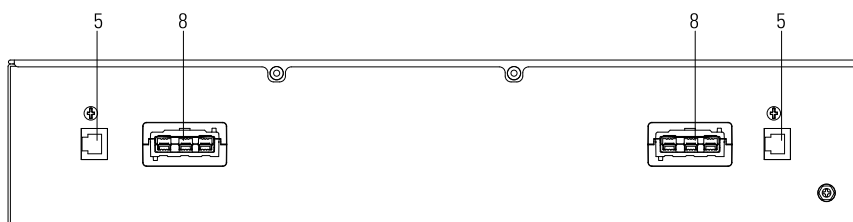

Legend

1	WLAN (HDMI)	2	USB	3	Ethernet
4	RPO / Dry in / Dry out	5	EBM auto detection	6	RS232
7	Slot card box	8	EBM connector	9	Input breaker (optional)
10	Input socket / Input terminal	11	Output socket / output terminal	12	Output fuse (optional)
13	Programmable output socket				

3. INSTALLATION

3.1 INSPECTING THE EQUIPMENT



If any equipment has been damaged during shipment, keep the shipping cartons and packaging materials for the carrier or place of purchase. Returns policy subject to supplier and not specific to the manufacturer

3.2 CHECKING THE ACCESSORY KIT

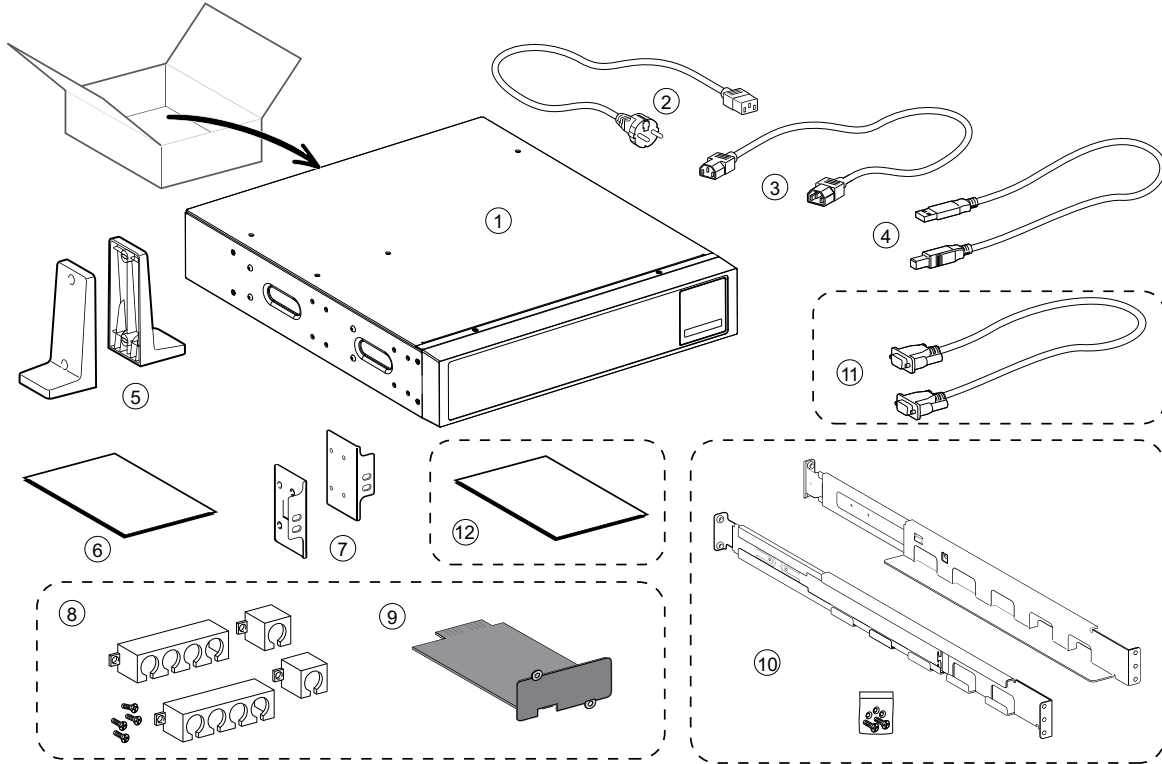

1	UPS	2	Input cable	3	Output cables
4	USB cable	5	Tower stands	6	User manual (English)
7	Rack ears	8	Cable lockers (optional)	9	Slot card (optional)
10	Rail kit (optional)	11	RS232 cable (optional)		
13	User manual (multi-language) (optional)				

3.3 INSTALLATION (UPS)



Always keep 200mm of space behind the UPS rear panel for ventilation.



Check that the indications on the name plate located on the top cover of the UPS meets the AC-power source and the electrical consumption of the total load.

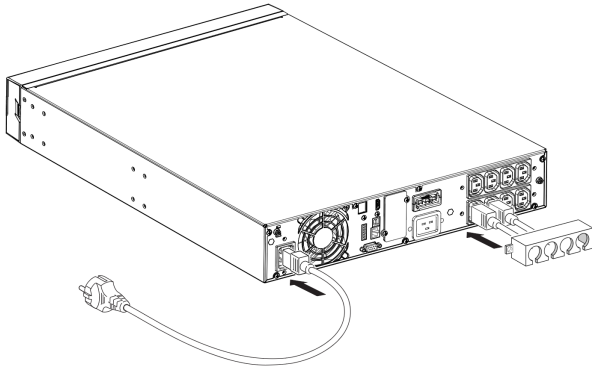

1. Connect the UPS input socket to the AC-power source using the cable from the protected equipment
2. Connect the loads to the UPS using the output cables



Note: The UPS charges the battery as soon as it is connected to the AC-power source, event if the power button is not pressed.

Once the UPS is connected to the AC-power source, 72 hours of charging is required before the battery can supply the rated backup time.

Input terminal and output terminal connection:

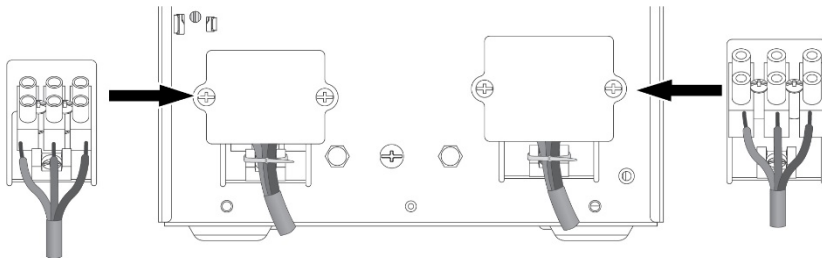

Rack installation

Follow steps 1 to 4 for module mounting on the rails.

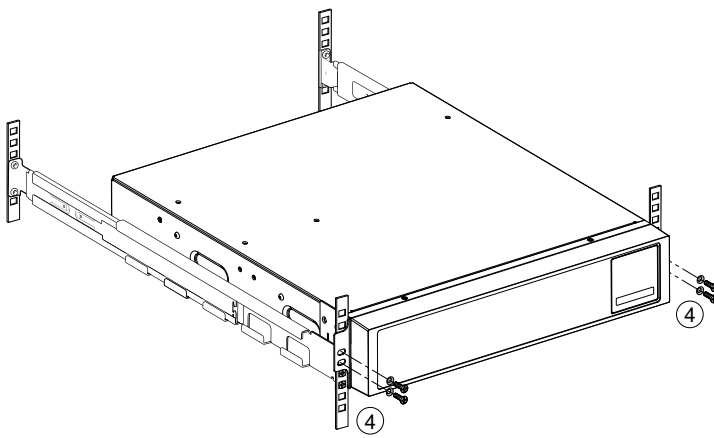
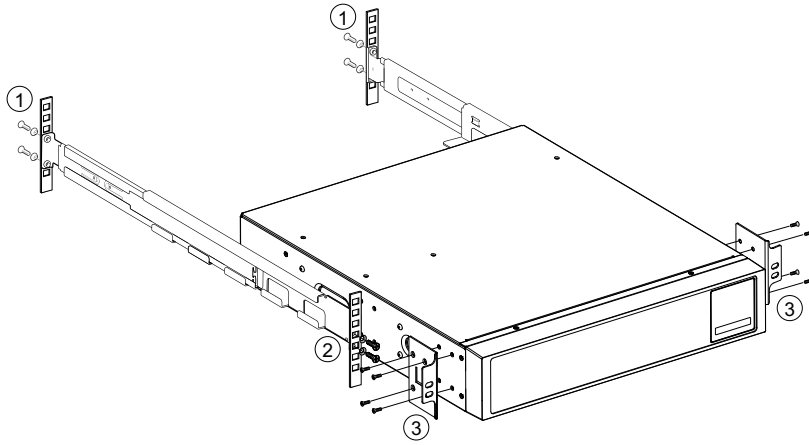

Tower Installation

Follow steps 1 to 5 for module mounting on the feet provided.

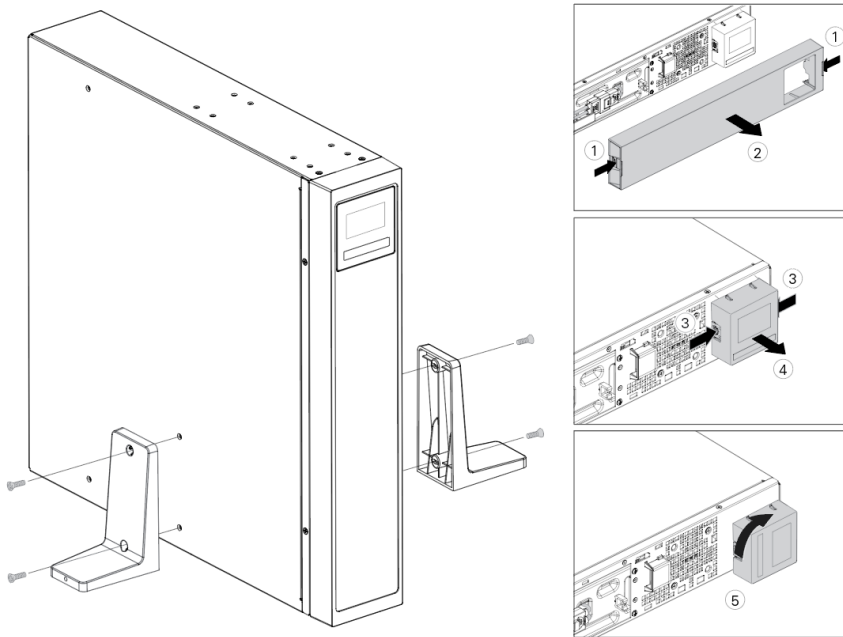

3.4 CONNECTING THE EBM(S)

A small amount of arcing may occur when connecting an EBM to the UPS. This is normal and will not harm the user.

Up to 4EBMs can be connected to the UPS.

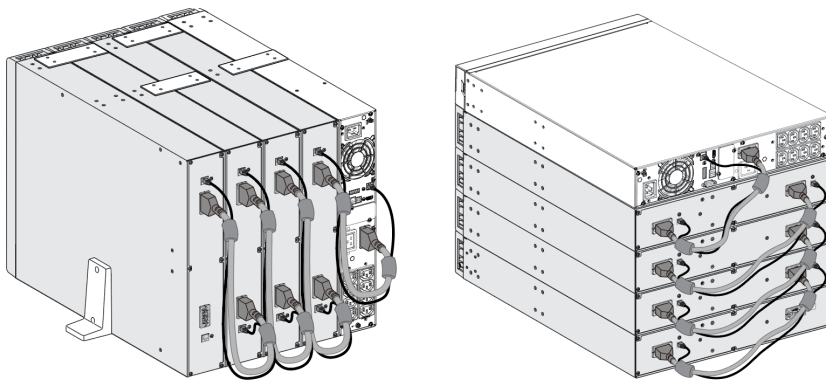

4. OPERATION

4.1 LCD PANEL

The UPS provides useful information about the UPS itself, load status, events, measurements and settings.

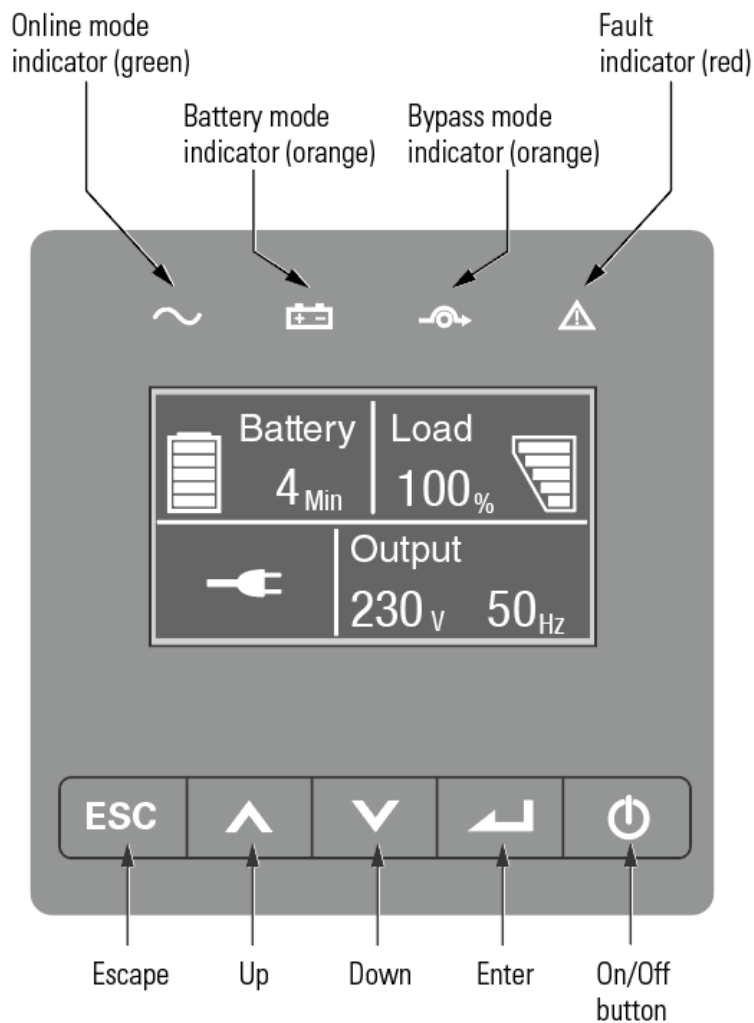

Indicator	Status	Description
~ Green	on	The UPS is operating normally in Online or High Efficiency Mode
⌚ Yellow	on	The UPS is in Battery Mode
↻ Yellow	on	The UPS is in Bypass Mode
⚠ Red	on	The UPS has an active alarm or fault. See Chapter 7 Troubleshooting for additional information.









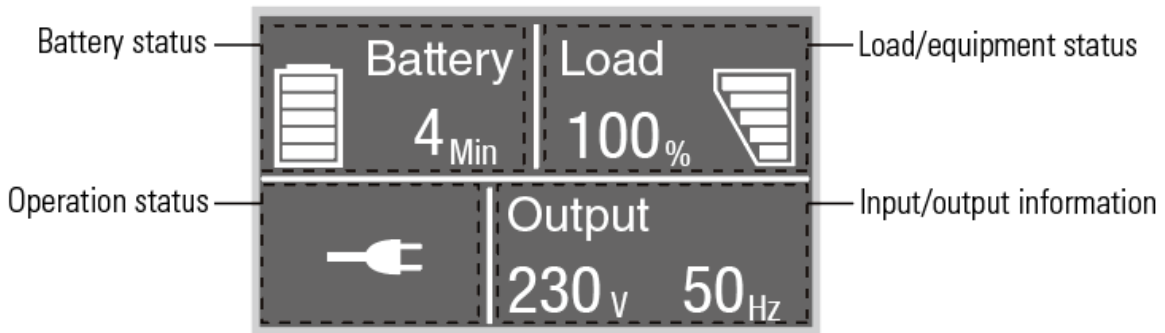

The following table shows the indicator status and description:

The button	Function	Illustration
	Power on	Press the button for >100ms & <1s to perform a cold start function (without mains)
	Turn on	When mains power is present, press the button for >1s to turn on the UPS
	Turn off	Press the button >3s to turn off the UPS
	Scroll up	Press to scroll up the menu
	Scroll down	Press to scroll down the menu
	Enter menu	Select / Confirm the highlighted option
	Exit the present menu	Press to exit current menu to main menu or the higher-level menu without changing a setting
	Mute buzzer	Press the button to mute the buzzer temporarily, once new working or fault is active, buzzer with work again

4.2 LCD DESCRIPTION

The LCD backlight automatically dims after 10 minutes of inactivity. Press any button to restore light to the screen.



Operation status	Cause	Description
	Standby mode	The UPS is off without an output
	Online mode	The UPS is operating normally and protecting the critical load
 1 beep every 4 seconds	Battery mode	An input failure has occurred, and the UPS is powering the equipment for shutdown, if possible
 1 beep every 1 seconds	Battery mode with battery low	This warning is approximate, and the actual time to shutdown may vary significantly
	High efficiency mode	Once mains is lost or outside UPS parameters, the UPS will transfer to online mode or battery mode and the load is supplied continuously.
	Converter mode	The UPS would free run with fixed output frequency (50Hz or 60Hz) The load should be derated to 60% in converter mode.
	Bypass mode	An overload or fault has occurred, or a command has been received, and the UPS is in bypass mode.
	Battery test	UPS is undertaking a battery test
	Battery fail	The UPS detects low battery voltage, or the battery has been disconnected
	Overload	Too much load attached to UPS output. Remove any unnecessary items to reduce the total load on the UPS
	Fault mode	A serious fault has occurred which requires urgent attention

4.3 DISPLAY FUNCTIONS

When starting the UPS, the display is in the default UPS status summary screen.

Main menu	Submenu	Display information or menu function
UPS status		UPS mode, IoT status, date/time, battery status and current alarms (if any)
Event log		Display the events and faults stored
Measurements		[Load] W VA P%, [Input/Output] V, [Temperature] C
Control	Go to Bypass	Transfers the UPS into Bypass mode
	Load segment	Load segment outlets on/off
	Start battery test	Starts a manual battery test
	Reset event list	Clear active fault
	Reset event list	Clear events and faults
	Reset com card / Reset IoT	Reset IoT and Modbus TCP function inside UPS
	Restore factory settings	Restore to default factory settings
Settings		Refer to Chapter 4.4, User settings
Identification		[Product name], [Serial number], [firmware revision], [IP/MAC address]

4.4 USER SETTINGS

Submenu	Available settings	Default settings
Password	Can be changed by user	4732
Change language	English, Italiano, Français, Deutsch, Español, Русский, Polski, 简体中文	English
User password	[enabled, ****], [disabled]	Enabled
Audible alarms	[enabled], [disabled]	Enabled
Output voltage	[200V], [208V], [220V], [230V], [240V]	[230V]
Output frequency	[autosensing], [converter 50Hz, 60Hz]	Autosensing
High efficiency mode	[disabled], [enabled]	Disabled
Auto bypass	[disabled], [enabled]	Disabled
Submenu	Available settings	Default settings

Start / Auto restart / Start from bypass	[disabled], [enabled]	Cold start / auto restart: enabled start from bypass: disabled
Site wiring fault	[enabled], [disabled]	disabled
Overload pre-alarm	[50% - 105%]	105%
External battery	[Auto detection]. [manual EBM: 0-4], [Manual Ah: 7-144Ah]	Auto detection 0 EBM
Charger current	[2A], [4A], [6A], [8A] for long backup	4A
Dry in signal	[disabled], [remote on], [remote off], [forced bypass]	Disabled
Dry out signal	[enabled], [disabled]	Bypass
Ambient temperature alarm	[enabled], [disabled]	Enabled
Battery time remaining	[enabled], [disabled]	Enabled
Date and time	Dd/mm/yyyy hh:mm	01/01/2020 00:00
LCD contrast	[-5 ~ +5]	[0]
IoT	[enabled], [disabled]	Disabled
Modbus TCP	[enabled], [disabled]	Disabled

i If the load is supplied from a transformer, it is recommended to enable the 'start from bypass' function.

4.5 STARTING THE UPS WITH UTILITY POWER

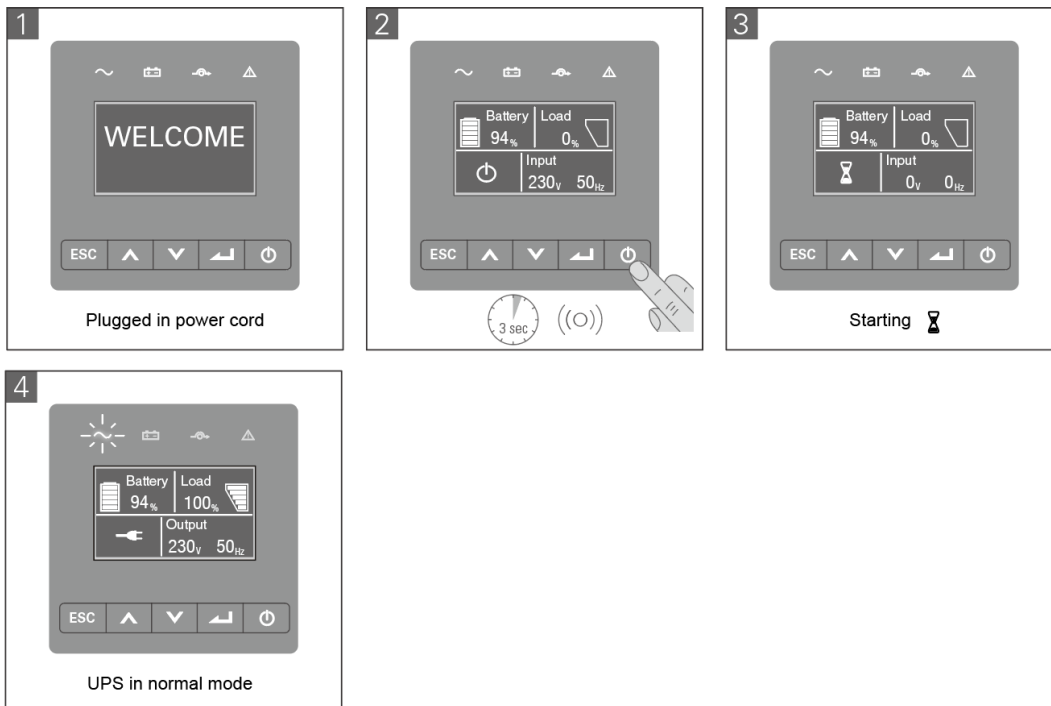

4.6 STARTING THE UPS ON BATTERY



Before using this feature, the UPS must have been powered by utility power with output enabled at least once.

Battery start can be disabled. Refer to the Chapter [4.4 User setting](#)

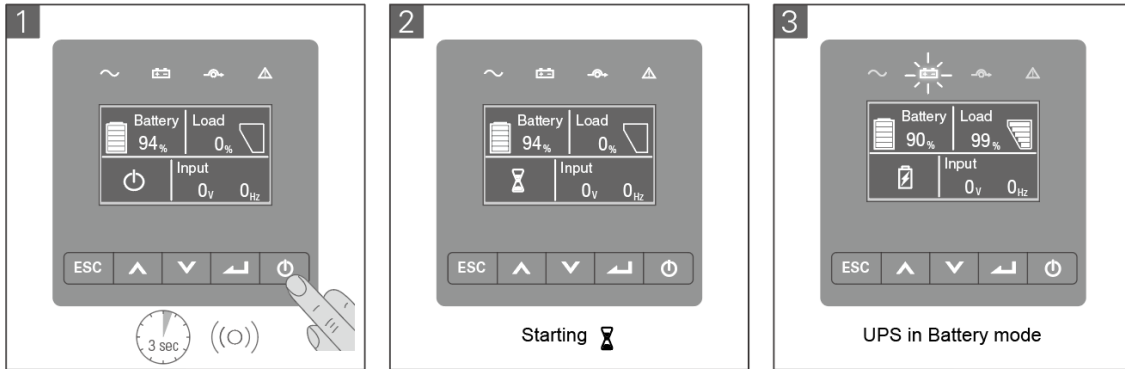

4.7 UPS SHUTDOWN

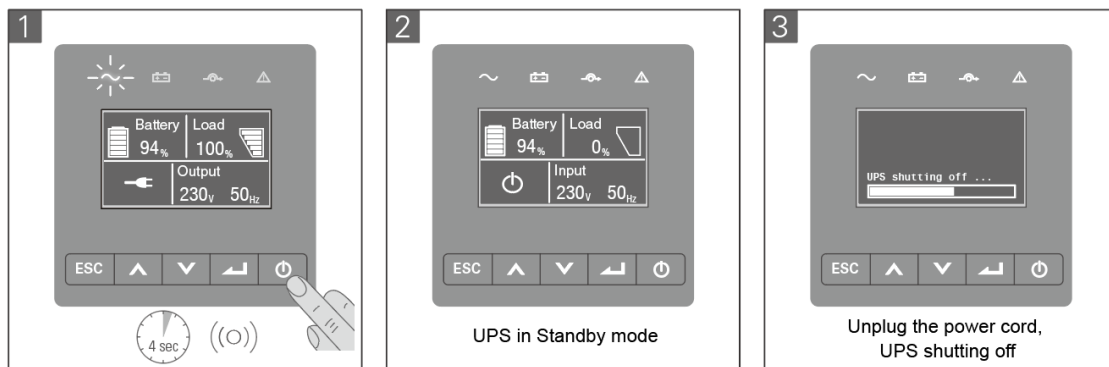

5. Communication

5.1 RS232 AND USB

1. Connect a communication cable to the serial or USB port on a computer
2. Connect the other end of the communication cable to the RS232 or USB communication port on the UPS

5.2 UPS REMOTE CONTROL FUNCTIONS

Remote power off (RPO)

When the RPO is activated, the UPS will cut off the output immediately, and continue to alarm.

RPO	Comments
Connector type	16 AWG Maximum wires
External breaker specification	60VDC/30VAC 20mA max

Dry in

Dry in function can be configured (see Settings > Dry in)

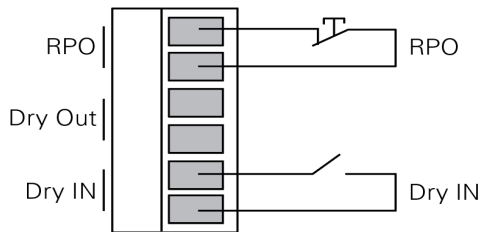

Dry out	Comments
Connector type	16 AWG Maximum wires
External breaker specification	60VDC/30VAC 20mA max

Dry out

Dry out is the relay out, dry out function can be configured (see Settings > Dry out)

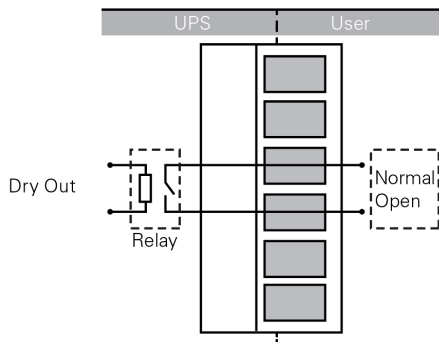

Dry out	Comments
Connector type	16 AWG Maximum wires
Inner relay specification	24VDC/1A

5.3 IOT

The built-in ethernet port and WLAN (optional accessory) ports enable market leading and easy to use IoT solutions for:

- A mobile application which allows users to remotely monitor UPS(s) and keep apprised about critical UPS events
- Remote report UPS faults and status (contact with your service provider for more details) from APP or registered APP account (email address)
- Automatic UPS and battery warranty expiry alerts from APP or registered APP account (email address)

IoT Connection

Wired connection

1. Connect UPS and router or switch with a network cable

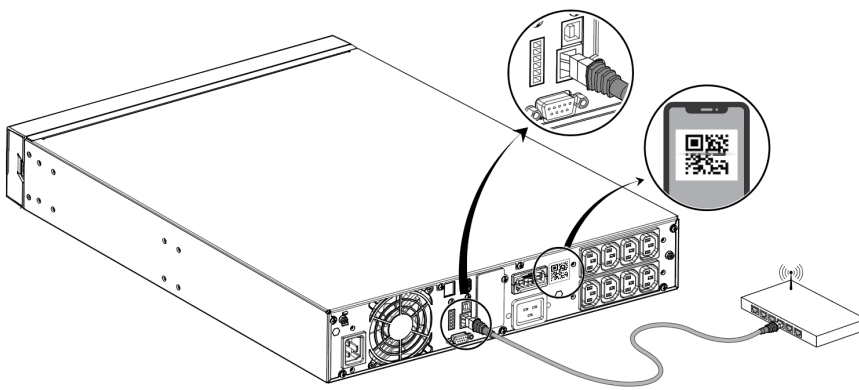

Please use CAT 6 shielded network cable.



The position of the QR code on the UPS image is for reference only, The label may be elsewhere on the UPS.

Make sure your IT settings can access the public network and Microsoft Azure cloud.

2. Enable the IoT function on the LCD (see Settings > IoT)
3. Search the “winPower View” from the Google Play store or Apple App store and download and install it on your device.
4. Open the app, register an account, log in and follow the instructions of the app.
5. Tap on the upper right corner, scan the SN barcode on the UPS label to add the device
- 6.

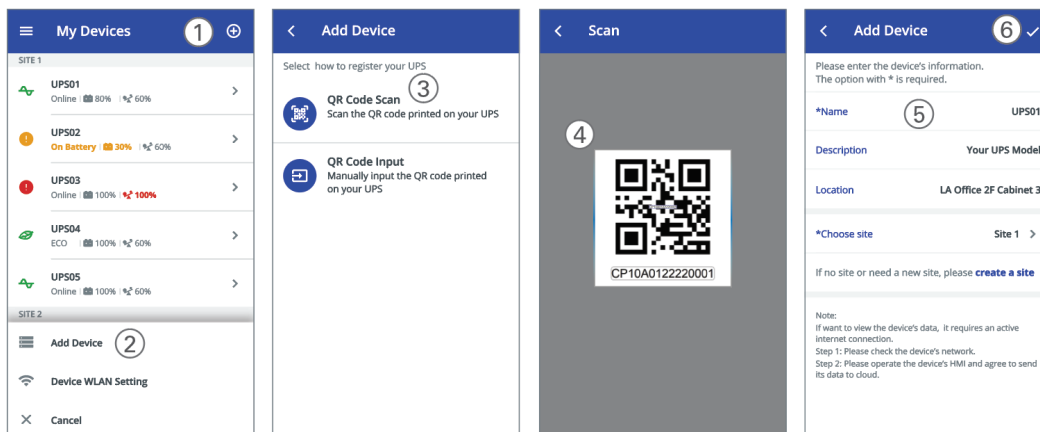

the APP.

The wireless module is optional, please contact your local distributor for details.

5.4 MODBUS TCP

Built-in ethernet port offers Modbus TCP feature to facilitate remote monitoring of the UPS into your own software. Contact your service provider for protocol details.

5.5 INTELLIGENT CARDS (OPTIONAL)

Intelligent cards allow the UPS to communicate with different types of devices in variety of networking environments. The UPS could use the following connectivity cards, please contact your local distributor for details.

- **SPYNMC** – Ideal monitoring solution enables user to monitor and control the status of a UPS on a web browser via the internet
- **SPYRC** – Provides voltage-free dry contact signals for programmable controller and management systems
- **SPYEMP** – Supports temperature and humidity sensors for remote environment monitoring. SPYNMC Card is required.

5.6 UPS MANAGEMENT SOFTWARE

5.6.1 WINPOWER

WinPower provides user-friendly interface to monitor and control your UPS. This unique software provides safe auto shutdown for a multitude of smart devices when power fails for an extended period of time. With this software, users can monitor and control any UPS on the same LAN.

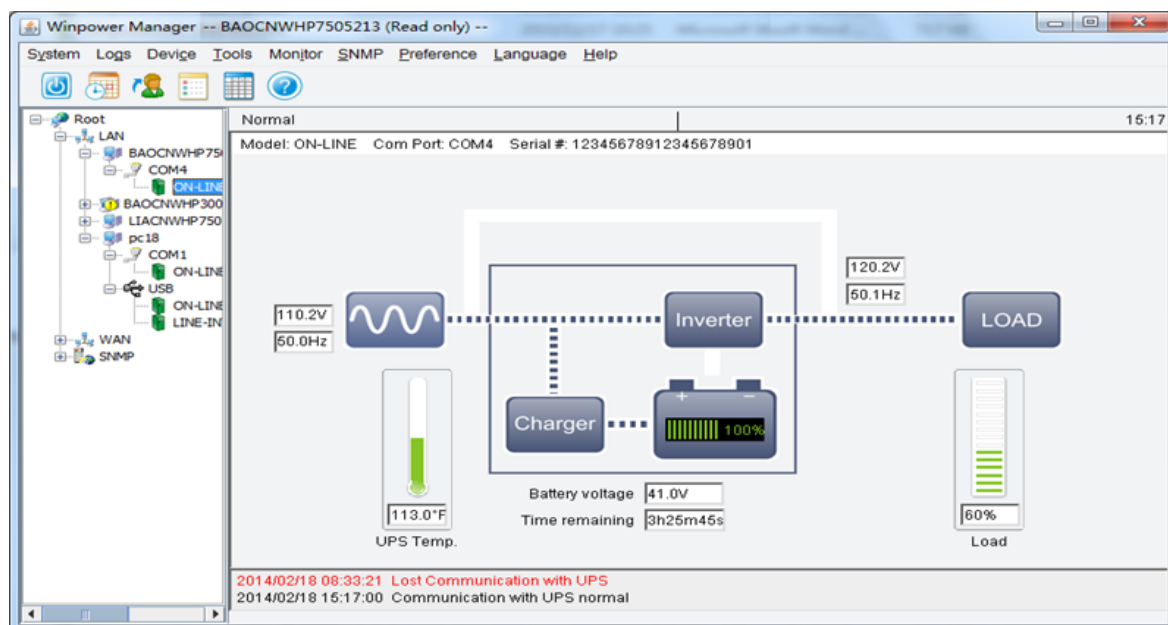

Installation procedure:

1. Go to the website:

<http://www.ups-software-download.com/content/ups-download-software/download.html>

2. Choose the operating system relevant to your needs and follow the instructions described on the website to download the software.

3. When downloading all required files from the internet, enter the serial No: **511C1-01220-0100-478DF2A** to install the software.

When you finish the installation process, restart your computer. The WinPower software will appear as a green plug icon located in the system tray, near the clock.

5.6.2 WinPower View App

WinPower View is a mobile application which allows you to centralize monitoring of UPS(s) connected to cloud. Please download it from the Google Play store or Apple APP store.

Please refer to the [chapter 5.3](#) for IoT connection.

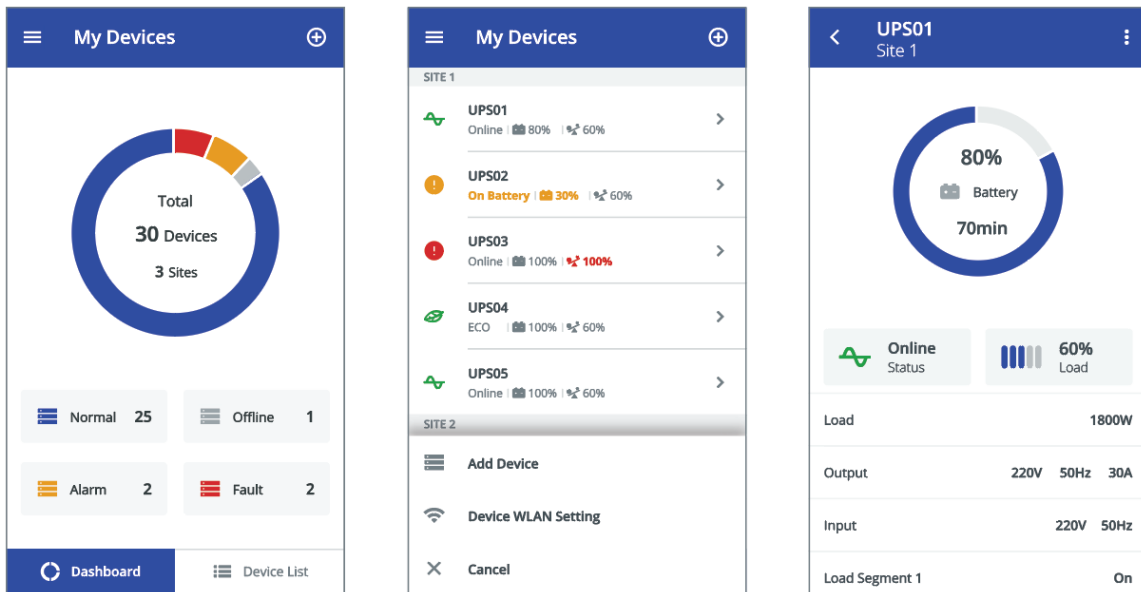

6. UPS MAINTENANCE

6.1 EQUIPMENT CARE

For the best preventive maintenance, keep the area around the equipment clean and dust free. If the atmosphere is very dusty, clean the outside of the system with a vacuum cleaner.

For full battery life, keep the equipment at an ambient temperature of 20°C (68°F).



The batteries are rated for a 3-5-year service life. The length of service life varies, depending on several factors, including the frequency of usage and ambient temperature. Batteries used beyond expected service life will often have severely reduced runtimes. Replace batteries at least every 4 years to keep units running at peak performance.

6.2 TRANSPORTING THE UPS



Please transport the UPS in the original packaging only. If the UPS requires any type of transportation, verify that the UPS is disconnected, turned off and the batteries are disconnected.

6.3 STORING THE EQUIPMENT

If you store the equipment for a long period prior to usage, we recommend the user recharges the battery at least every 6 months by connecting the UPS to utility power. Batteries are to be charged for 72 hours after long-term storage.

If batteries are not recharged over a 6-month period, do not use them. Contact your service representative.

6.4 REPLACING BATTERIES



DO NOT DISCONNECT the batteries while the UPS is in Battery mode.



Consider all warnings, cautions, and notes before replacing batteries.

- Servicing should be performed by qualified service personnel only, with knowledge of batteries and the required precautions. Keep unauthorised personnel away from batteries.

6.5 RECYCLE

Contact your local recycling or hazardous waste centre for information on the correct disposal of the used equipment.



Do not dispose of the batteries in the fire. Which may cause battery explosion. The batteries must be rightly disposed of according to local regulation.

Do not open or destroy the batteries. Escaping electrolytes can cause injury to the skin and eyes. It may be toxic.



Do not discard the batteries in the bin.

This product contains sealed lead acid batteries and must be disposed of as it's explained in this manual.

Pb

For more information, contact your local recycling centres, and re-use and treatment facilities.



The crossed-out wheeled bin symbol indicates that waste electrical and electronic equipment should not be discarded together with unseparated household waste but must be collected separately. The product should be handed in for recycling in accordance with the local environmental regulations for waste disposal.

By separating waste electrical and electronic equipment, you will help reduce the volume of waste sent for incineration or land-fills and minimize any potential negative impact on human health and environment.







7. TROUBLESHOOTING

Typical alarms and faults:

To check the UPS status and event log:

1. Press any button on the front panel display to activate the menu options
2. Press the button to select event log
3. Scroll through the listed events and faults.

The following table describes typical conditions.

Conditions	Possible cause	Action
Battery mode  LED is On, 1 beep every 4 seconds	A utility failure has occurred, and the UPS is in battery mode	The UPS is powering the equipment with battery power. Prepare your equipment for shutdown.
Battery low  LED is On. 1 beep every second	The UPS is in Battery mode and the battery is running low.	This warning is approximate, and the actual time to shutdown may vary significantly.
No battery  LED is on. Beep continuous	The batteries are disconnected.	1. Verify that all batteries and comms cable (RJ45) are properly connected. 2. Check the LCD menu: Settings – External battery. If select the “Manual EBM” and Value is 0, please set the right value.
Battery fault  LED is on. Beep continuous	The battery test has failed due to bad or disconnected batteries. Alternatively, the battery minimum voltage has been reached in discharge mode.	Verify that all batteries are properly connected. Start a new battery test: if the condition persists, contact your service representative.
The UPS does not provide the expected backup time	The batteries need charging or service.	Apply utility power for 48 hours to charge the batteries. If the condition persists, contact your service representative.
Bypass mode  LED is on	An overload or a fault has occurred, or a command has been received and the UPS is in Bypass mode. Or auto bypass function is enabled.	Equipment is powered but not protected by the UPS. Check for one of the following alarms: overtemperature, overload, UPS failure or auto bypass setting.
Power overload 	The power demand exceeds the UPS capacity (greater than 105% of the nominal)	Remove some of the equipment from the UPS. The alarm resets when the load is reduced sufficiently.

LED is on. Beep every second		
Over temperature warning  LED is On. 1 beep every second	The UPS internal temperature is too high. At the warning level, the UPS generates the alarm but remains in the current operating state.	Clear vents and remove any heat sources. Ensure the airflow around the UPS is not restricted.
The UPS does not start.	The input source is not connected correctly	Check the input connections.
	The remote power off (RPO) switch is active or the RPO connector is missing	If the UPS Status menu displays the "Remote Power Off" notice, inactivate the RPO input.
Emergency power off	RPO is active	1.Check the RPO connector status 2.Reset the RPO fault through LCD. Main menu – Control - Reset fault state.
Fan fault	Fan abnormal	Check if the fan is running normally
Site fault	Phase and neutral conductor at input of UPS system are reversed	Site Fault detection disabled by default. It can still be enabled / disabled from the LCD settings menu. Reconnect all input wires.
Over temperature fault	Temperature is too high, UPS goes to bypass or stopped.	Check the ventilation of the UPS and check the ambient temperature
Output short circuit	Output short circuit occurred.	Check the output of UPS and loads, make sure the short circuit is removed before turning on again.
App cannot connect to UPS	IoT is disabled	Enable IoT function in LCD
	Your IT settings may block UPS get cloud connected (NTP, Proxy, etc.)	please refer to WinpowerView app help file

8. SPECIFICATIONS

8.1 UPS BLOCK DIAGRAM

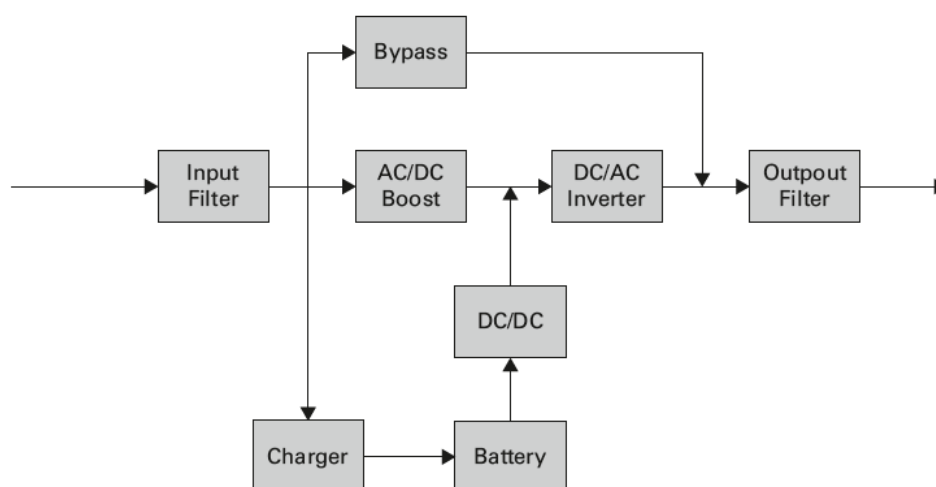

8.2 UPS SPECIFICATION

Model name		SPY1500RMI2U	SPY3000RMI2U
Power rating	VA/Watt	1500VA / 1500W	3000VA / 3000W
Efficiency	Line mode	89%	93%
	ECO mode	97%	
Input performance	Voltage range	160-300V 100% load, 110-160V derating to 50% load linearly	
	Rated frequency	50Hz/60Hz	
	Frequency range	40Hz-70Hz (45Hz-55Hz, 54Hz-66Hz @ load>60%)	
	PF	>0.99	
	THDI	<5%	
Input connection	Socket	1x IEC C14	1x IEC C20
Output performance	Rated voltage	200/208/220/230/240 VAC (derating 10% at 208V, derating 20% at 200V)	
	Rated frequency	50Hz/60Hz	
	Maximum PF	PF=1	
	Voltage accuracy	±1%	
	THDV	<1% linear load; <5% nonlinear load	
	Transfer time	0ms@line <-> battery; 4ms @ line <-> bypass; 10ms @ ECO <-> Inverter	
	Crest ratio	Max 3:1	
	Overload	100%<load≤105% continuous. 105%< load ≤125% for 5 minutes 125%<load≤150% for 30 seconds. >150% for 500ms.	
Output connection	Socket	1 main outlet group (with 4 x IEC C13) 1 programmable outlet group (with 4 x IEC C13)	1 main outlet group (with 1 x IEC C19 + 4 x IEC C13) 1 programmable outlet group (with 4 x IEC C13)
	Load segment control	Yes, 1 programmable load segment control	
Short circuit current (RMS) / protect time	Bypass mode	550A/2.8ms	699A/7ms
	Normal / Battery mode	25A/100ms	54A/100ms
Battery	Voltage	36VDC	72VDC
Maximum EBM quantity		4	
EBM auto detection		Yes	
Battery hot swappable		Yes	

Charger	Charging method	Optimize Battery Management (OBM)	
	Charging current	8A	
Other mode	CVCF	Yes (derating to 60% load)	
HMI	Display	Dot matrix LCD (optional segment LCD)	
	Language	Multi-Language	
	USB	USB 2.0 with HID power device	
	RS232	Yes (DB9)	
	Dry in / out	1 programmable dry in; 1 programmable dry out	
	RPO	Yes	
	Intelligent slot	Yes (for card)	
	Network card	Optional, NMC card	
	Modbus card	Optional, CMC card	
	Dry contactor card	Optional, AS400 Long Card	
	Wireless module	Optional	
	IoT Ethernet port	RJ45	
Monitoring software	Winpower, Winpower View APP		
Physical performance	Dimensions (WxDxH) mm	438*445*85.5(2U)	438*600*85.5(2U)
	IP protection level	IP20	
	Plug solid	Optional	
	Wheel	No	
Environment	Operating temperature	: 0-40°C	
	Relative humidity	0-95%	
	Operating altitude	0~3000m (the load derating 1 % every up 100m @1000~3000m)	
	Acoustic noise	<45dB at front 1m	<50dB at front 1m
Certification	CE, IEC/EN 62040		
EMI	Conduction / radiation	C2	
EMS	ESD	IEC/EN 61000-4-2	
	RS	IEC/EN 61000-4-3	
	EFT	IEC/EN 61000-4-4	

	Surge	IEC/EN 61000-4-5
Accessory	Input power cable	Yes
	Output power cable	Yes (For IEC models)
	EBM cable	Yes (in EBM)
	USB cable	Yes
	RS232 cable	Optional
	Rail kit	Optional
	Tower feet	Yes
	Rack ear	Yes
	Manual (English)	Yes